

FuelTech



FT600
FT550
FT550LITE
FT450

OWNER'S MANUAL

1. Index

2.	Presentation	6	9.2 Connector diagram - Harness FT400 to FT550/LITE.....	41	
3.	Warranty terms	7	9.3 Connector Diagram - Harness FT400 to FT550/LITE	41	
4.	Characteristics	8	9.4 A - Connector Diagram - Harness FT500 to FT550/LITE	42	
4.1	Harness connections A connector - FT450 / FT550 and LITE.....	10	9.5 B - Connector Diagram - Harness FT500 to FT550/LITE.....	42	
4.2	Harness connections B-connector (FT550 / LITE Only)	12	9.6 A - Connector diagram - Harness FT500 to FT600.....	43	
4.3	Harness connections A-connector (FT600)	14	9.7 B - Connector diagram - Harness FT500 to FT600.....	43	
4.4	Harness connections B-connector (FT600)	16	10.	Fuel injectors	44
4.5	Output table of FT	17	11.	Ignition.....	44
4.6	PowerShift Connector (FT550 / LITE and FT600)	18	12.	Sensors and actuators.....	47
4.7	Auxiliary outputs	18	12.1	Intake air temperature sensor	47
4.8	Internal MAP sensor.....	18	12.2	Engine temperature sensor	47
4.9	USB port.....	18	12.3	Fuel and oil pressure.....	47
4.10	FuelTech CAN network.....	18	12.4	Throttle position sensor (TPS).....	47
4.11	Connector disassembly	19	12.5	Crank trigger/RPM sensor.....	48
5.	First steps with FuelTech read before installation	19	12.6	Camshaft position sensor.....	50
6.	Getting to know the ECU.....	20	12.7	O2 sensor	50
6.1	Dashboard	20	12.8	Step motor – idle speed.....	50
6.2	Main menu.....	20	13.	Auxiliary outputs	52
6.3	FTManager shortcuts	21	13.1	Cooling fan 1 and 2.....	52
6.4	Warning sounds in FT550LITE.....	22	13.2	Idle valve.....	52
6.5	Dashboard screen	22	13.3	Air conditioning	52
6.6	Diagnostic panel.....	22	13.4	Shift Alert	52
6.7	Test time based features	23	13.5	Fuel pump.....	52
6.8	Compression test	24	13.6	Variable camshaft control/Powerglide gearbox.....	52
6.9	Internet Remote Tuning.....	24	13.7	Progressive nitrous control	53
6.10	FTManager exclusive features	24	13.8	Boost Control – N75	53
6.11	FTManager - Datalogger	25	13.9	BoostController	54
7.	Engine settings.....	26	14.	Electronic throttle control	55
7.1	Engine setup.....	27	14.1	Electronic throttle control (FT600).....	55
7.2	RPM signal.....	29	14.2	Connection – throttle bodies and pedals	55
7.3	Cam sync sensor.....	30	14.3	Electronic throttle control (FT550 / LITE).....	56
7.4	Ignition.....	31	14.4	Connection – throttle bodies and pedals	56
7.5	Fuel injection	32	15.	Sensors and Calibration.....	57
7.6	Pedal/Throttle	33	15.1	Ignition calibration.....	57
7.7	Idle actuators	35	15.2	TPS calibration	57
7.8	FuelTech base map	35	15.3	Electronic throttle/pedal calibration	57
7.9	Fuel injectors deadtime.....	36	15.4	Fuel/oil pressure sensors inputs	58
7.10	Ignition Dwell	36	15.5	Intake air and engine temperature sensors	58
7.11	Ignition energy	36	15.6	O2 sensor inputs.....	59
7.12	Map options	37	15.7	Speed inputs	60
7.13	Advanced map options.....	37	15.8	Driveshaft RPM	60
8.	Electrical installation	38	15.9	Input shaft RPM	61
9.	Wiring PowerFT ECUs to harnesses from previous ECUs	40	15.10	MAP Sensor	61
9.1	Connector diagram - Harness FT250, FT300, FT350 to FT450	40	15.11	Gear detection	61
			15.12	Nitrous bottle pressure	62
			15.13	Clutch position	62
			15.14	Clutch pressure.....	62

15.15 Ride Height	63	17.18 Fuel injection phase angle table	77
15.16 Pitch Rate	63		
15.17 CAN communication	63	18. Ignition tables adjust.....	78
15.18 EGT.....	63	18.1 Main ignition table	78
15.19 Wastegate Pressure	64	18.2 Overall ignition trim	78
15.20 Internal accelerometer (FT550 /LITE and FT600)	64	18.3 MAP/TPS compensation	78
15.21 Brake Pressure	65	18.4 Engine temperature compensation	79
15.22 Front and rear shocks	65	18.5 Intake air temperature compensation	79
15.23 Flex Fuel	65	18.6 Rotary timing split.....	79
15.24 Back Pressure	65	18.7 Individual cylinder trim	79
15.25 Oil pan pressure	66	18.8 Rotor compensation.....	79
15.26 Transmission pressure	66	18.9 Timing limits	80
15.27 Transmission temperature	66	18.10 Engine Start.....	80
15.28 Torque converter pressure	66	18.11 Gear compensation.....	80
15.29 Intercooler temperature	66	18.12 Gear shift compensation	80
15.30 Front and rear tires temperature.....	66		
15.31 Track temperature.....	66	19. Other functions.....	81
15.32 Engine Coolant pressure.....	66	19.1 Internal datalogger	81
15.33 Turning lights	67	19.2 Accelerometer and gyroscope (FT550 and FT600)	82
15.34 Low beam / High beam.....	67	19.3 Idle speed control.....	83
15.35 Turbocharger RPM.....	67	19.4 Deceleration cut-off	85
15.36 Fuel flow	67	19.5 Revolution limiter	85
15.37 Flywheel RPM (Clutch basket)	67	19.6 Shift Light.....	86
15.38 Automatic transmission range selector	67	19.7 Thematic Fan #1	86
15.39 Paddle Shift.....	68	19.8 Thematic Fan #2.....	87
15.40 Brake	69	19.9 Air conditioning	87
15.41 Multifunction button	69	19.10 Fuel pump.....	88
15.42 Battery temperature	69	19.11 Cold start auxiliary	88
15.43 Compressed air pressure.....	69	19.12 Camshaft control	89
15.44 Fuel Consumption Control.....	69	19.13 Progressive nitrous control #1 and #2.....	89
		19.14 Generic duty cycle output	90
16. Starting the engine for the first time	71	19.15 Boost activated output #1 and #2	91
16.1 First engine start.....	71	19.16 Tachometer output.....	91
16.2 Ignition calibration.....	71	19.17 Wastegate boost pressure control #1 and #2	91
		19.18 Power shift (GearController FT550 / LITE and FT600).....	96
17. Fuel tables adjust.....	72	19.19 Start Button	97
17.1 Main fuel table	72	19.20 RPM activated output.....	98
17.2 Overall fuel trim	72	19.21 Pit limit	98
17.3 RPM compensation	72	19.22 Active traction control.....	99
17.4 O2 Closed Loop.....	73	19.23 Generic Outputs	100
17.5 Idle speed by TPS table.....	74	19.24 Flex Fuel	100
17.6 Acceleration fuel enrichment and decay	74	19.25 Blip / Heel and toe	102
17.7 Engine temperature compensation	75	19.26 Variable Camshaft (VT).....	102
17.8 Intake air temperature compensation	75	19.27 Automatic Transmission Control.....	105
17.9 Battery voltage compensation.....	75	19.28 Lockup Control	108
17.10 MAP / TPS compensation.....	76	19.29 Push to pass (P2P).....	108
17.11 Prime pulse	76	19.30 Anti-lag / Pops & Bangs / Engine brake.....	109
17.12 Engine start	76	19.31 Compressed air control	110
17.13 Post-start enrichment	76	19.32 Advanced gear shift manager	111
17.14 Individual cylinder trim	77	19.33 Electronic Wastegate Control	113
17.15 Rotor compensation.....	77	19.34 eGate Important Information	114
17.16 Gear based compensation	77	19.35 eGate #1 and #2 position calibration	115
17.17 Gear shift fuel enrichment	77	19.36 eGate #1 and #2 temperature.....	115

19.37 Control by external reference.....	117	23.15 Odometer and Hourmeter	146
19.38 PWC Controls	118	23.16 Practice Tree Game	146
19.39 Frequency control.....	118		
19.40 Water pump.....	119	24. File manager.....	147
19.41 Vehicle lights control	119	24.1 FuelTech base map generator	147
19.42 Power brakes control	120	24.2 Edit map file name.....	147
19.43 Timed main relay	120	24.3 Copy map to another file	147
19.44 Electronic Blow Off control	121	24.4 Erase file.....	147
19.45 External TCU control	121	24.5 Selection by button.....	147
19.46 Water methanol injection (WMI)	123		
20. Drag race features	125	25. Electrification	148
20.1 Burnout mode	125	25.1 Glossary.....	148
20.2 3-step (boost spool)	125	25.2 Power Train Settings.....	148
20.3 2-step rev limiter	126	25.3 EV output configuration	149
20.4 Linelock Brake Control	127	25.4 Torque and Regen	149
20.5 Timing table for rev launch	128	25.5 Battery.....	150
20.6 Gear shift output.....	128	25.6 DCDC Converter.....	151
20.7 Time based fuel enrichment	129	25.7 Driveability.....	151
20.8 Pro-Nitrous.....	131	25.8 Charging Control	152
20.9 Time based output.....	133		
20.10 Wheelie Control.....	133	26. Rotary engines setup	153
20.11 Davis Technologies	134	26.1 Crank angle sensor installation and alignment	153
20.12 Time based throttle opening	134	26.2 Crank angle sensor wiring.....	153
20.13 Staging control.....	135	26.3 ECU setup.....	154
20.14 Mechanical fuel injection controller	135	26.4 Ignition coils wiring.....	154
20.15 Launch delay controls (delay box)	136		
20.16 Time based individual ignition trim	138	27. Electrical diagram - example FT600.....	155
20.17 Time based individual fuel trim	138		
20.18 DialBoard	138	28. FT450 and FT550 mounting kit	159
20.19 Throttle stop control	138		
		29. Bracket dimensions	160
21. Alert settings.....	139		
21.1 General alert settings.....	139	30. FT CAN 2.0 protocol	163
21.2 Alerts.....	139	30.1 Physical layer	163
		30.2 IDENTIFICATION	163
22. Favorites	141	30.3 DATA FIELD	163
		30.4 Attachments	165
23. Interface settings	142	30.5 Connector Pinout.....	172
23.1 Day/night mode selection	142		
23.2 LCD backlight settings (FT600 only)	142		
23.3 LED configuration (FT600 only)	142		
23.4 Virtual LEDs configuration (FT450 and FT550)	143		
23.5 Alert sound settings	143		
23.6 Dashboard setup.....	143		
23.7 Startup screen selection	144		
23.8 Splash Screen	144		
23.9 Password Protection setup.....	144		
23.10 Clear peaks	145		
23.11 Measurement units	145		
23.12 Demonstration mode	145		
23.13 Touchscreen calibration	145		
23.14 Serial number and software version.....	146		

2. Presentation

Congratulations, You're now part of the high performance world of FuelTech!

The equipment that you just acquired is the same being used in different vehicles all over the world, whether it be for a street car, motorcycle, jet ski, boat, ATV or professional series drag race combination...we have you covered!

From all of us at FuelTech, we wish you fun on your path and many victories, because winning is in our DNA!

Inspired by our passion of victories, be it on the track or a personal one like having a perfectly tuned car, and writing new chapters in our history between automobilism and technology, FuelTech created the PowerFT line of ECU's, with it you will enjoy features developed to extract the maximum performance and safety out of your project, street or drag car, off road vehicle, motorcycle or any other application that needs functionalities with ease of use and great results.

The PowerFT platform is capable of managing any type of Otto cycle engine(with cylinders) or Wankel (with rotors). It has sequential, semi-sequential and multipoint fuel injection as well as sequential, distributor or wasted spark ignition, both with either simple (2D) or advanced (3D tables), besides that , there are many other features made to improve functionality on a variety of applications, allowing for better drivability and comfort. All this versatility is also applied to the hardware, making it possible to customize its inputs to use factory sensors and assigning outputs to different roles, rendering it practically impossible not to suit to your project.

The PowerFT ECU's have no limitation in regards to features except when special hardware is needed, like with the powershift, internal accelerometer and drive by wire. The main integrated features of all ECU's are wastegate boost control (Boostcontroller), O2 closed loop corrections, idle control by timing and actuators, nitrous control, active traction control, as well as dedicated features to obtain the best results in drag racing.

All the ECU's feature a CAN bus to create a network with other products, making the installation of upgrades even simpler and easier, the USB port also allows a fast and robust communication with the FTManager software.

Another great feature is the 256 channel datalogger, with a resolution of up to 200hz for detailed analysis and fine adjustments that could make all the difference to attain victory. Through FTDatalogger software you can quickly and efficiently visualize every logged channel and easily make changes to the engine management as well as using the diagnostic feature (also accessible on the ECU screen and FTManager) to identify problems.

FuelTech is concerned with your engine safety and created an extensive range of alerts and safe modes to help protect your engine in dangerous and critical situations.

The FuelTech FT450 is the perfect choice for cost-effective builds. Featuring a robust and waterproof plastic housing, an automotive 26 pin connector, 7 inputs and 10 outputs that are totally configurable. Its 4.3" display, along with same dashboard as the FT600, makes the heads up of information to the driver much more clearer while enabling street cars to have an engine start button and virtual LEDs to use with warning lights such as high beam, turn signals and much more. The display also allows for complete access to all map adjustments, so its possible to edit tables and other settings without the need of a computer, the perfect integration between ECU and Dashboard.



The FT550 is ideal for projects that need more resources, it has integrated powershift, internal accelerometer (G force sensor) and gyroscope (inclination sensor), and drive by wire control. Features a robust and waterproof plastic housing with 52 pins automotive connectors, 2 CAN ports, 14 inputs and 24 outputs that are totally configurable.



The FT600 is the most complete ECU and Dashboard available on the market.

It features an waterproof aluminum case with superseal automotive connectors with a total of 68 pins (21 inputs and 32 outputs), 2 CAN ports, internal accelerometer and gyroscope as well as integrated powershift feature. It also has 10 LEDs with RPM, activation and colors configurable, 4 side LEDs that can be used for alerts and a 4.3" anti-glare display.



3. Warranty terms

The use of this equipment implies the total accordance with the terms described in this manual and exempts the manufacturer from any responsibility regarding to product misuse

Read all the information in this manual before starting the product installation.



NOTE

This product must be installed and tuned by specialized auto shops and/or personnel with experience on engine tuning.

Before starting any electric installation, disconnect the battery.

The inobservance of any of the warnings or precautions described in this manual might cause engine damage and lead to the invalidation of this product warranty. The improper use of the product might cause engine damage.

This product does not have a certification for the use on aircraft or any flying devices, as it has not been designed for such use purpose.

In some countries where an annual inspection of vehicles is enforced, no modification in the OEM ECU is permitted. Be informed about local laws and regulations prior to the product installation.

Important warnings for proper installation of this product:

- Always cut the unused parts of cables off NEVER roll up the excess.
- The black wire of the harness MUST be connected directly to the battery's negative terminal, as well as each one of the sensors' ground wires.
- It is recommended to wire the **black/white** wire directly to the **battery negative** terminal, making sure that the ECU is well grounded. If the ECU wiring has not been made properly, it may cause irreparable problems to the ECU.



IMPORTANT

The all black and black/white ground wires must go SEPARATELY to the negative battery terminal.



WARNING

- ***It is a good practice to save your maps on the PC, as a security backup. In case of problems with your ECU, this will be the guarantee that your calibrations are saved. In some cases, when the ECU is upgraded by the factory, its memory may be erased also.***
- ***It's not possible to change the interface language on the PowerFT platform.***



IMPORTANT

PowerFT ECU's (FT450, FT550 and FT600) are water proof, however, some specific instructions must be followed:

- ***Do not point pressure washers directly to the ECU screen***
- ***When removing wires from the ECU connector, be sure to use Super seal connector hole plugs, to completely seal the ECU (TE Connectivity PN 4-1437284-3)***
- ***Equipment with high vibration: It's MANDATORY to use a rubber mounts (sold separately). Use the screws provided in the fixing kit or use Ø1/4"-20 x 1/2" UNC screws with a torque of 6 Nm for fixing.***

Limited Warranty

This product warranty is limited to one year from the date of purchase and covers only manufacturing defects upon presentation of purchase invoice.

This ECU has a serial number that's linked to the purchase invoice and to the warranty. In case of product exchange, please contact FuelTech tech support.

Damages caused by misuse of the unit are not covered by the warranty. This analysis is done by FuelTech tech support team.

The violation of the warranty seal results in the invalidation of the Product Warranty.

All PowerFT ECUs are protected by US Patent 11,215,158

Manual version 2.9 – August/2025

ECU version – 5.4

FTManager version - 5.4

4. Characteristics

Specifications	FT450	FT550 / LITE	FT600
Otto cycle engine control	8	12	12
Wankel engines (rotary)	2	4	4
Sequential, semi sequential and multipoint fuel control	YES		
Distributor and crank trigger ignition control	YES		
Wasted spark and sequential ignition control	YES		
Electronic throttle body Control (Drive-By-Wire)	NO	YES	YES
Idle speed control by PWM valve	YES		
Idle speed control by electronic throttle, stepper motor and ignition timing	NO	YES	YES
Closed loop injection through oxygen sensor (wide band lambda sensor)	YES		
Real time programmable by the screen or PC through FTManager Software	YES		
Inputs			
Differential input for RPM signal	YES		
Differential input for cam sync signal	NO	NO	YES
Input channels totally configurable - digital and analogical	7	14	20
2 high sensibility inputs used preferably for gear shifter force sensor	NO	YES	YES
Editable sensors reading scale	YES	YES	YES
103psi internal MAP sensor (7 bar - absolute), 14.7psi of vacuum and 88psi of positive pressure (boost);	YES		
1 USB port for computer and FuelTech software connection;	YES		
CAN ports for FuelTech FTCAN 2.0 or FTCAN 1.0 communication with FuelTech WB-O2 Nano, FuelTech EGT-8 CAN, Racepak IQ3, VNET, AiM, etc).	1	2	2
Outputs			
Configurable outputs channels	10	24	32
Blue output ¹	6	12	16
Gray output ²	4	8	8
Yellow output ³	0	4	8
Injection control			
Sequential injection (Blue outputs)	6	12	16
Closed loop fuel control through O2 sensor (wide band sensor)	YES		
2 injector banks (staged injection banks A and B)	YES		
Main map to MAP or TPS to RPM	YES		
Main map 3D advanced until 32x32 points (completely adjustable map index and size)	YES		
Simplified 2D map with up to 1x32 cells per MAP or TPS and RPM compensation of up to 1x32 cells (completely adjustable map index and size)	YES		
Injection time resolution 0.001ms	YES		
Fuel enrichment and decay adjust	YES		
Individual cylinder trim setting by MAP or RPM	YES		
Starting engine map with the engine temperature	YES		
Ignition control			
Sequential ignition with individual coil	5 ⁴	8	8
Main map to MAP or TPS to RPM	YES		
Main map 3D advanced until 32x32 points (completely adjustable map index and size)	YES		
Simplified 2D map with up to 1x32 cells per MAP or TPS and RPM compensation of up to 1x32 cells (completely adjustable map index and size)	YES		
Ignition angle resolution 0.01°	YES		
Timing compensation (air temperature, engine and gear)	YES		

Dashboard screen / On board computer	FT450	FT550 / LITE	FT600
Screen dashboard which displays different sizes and styles to be used with any existing equipment or sensor	YES ⁶		
Upper tab with 10 LED lights, colored RGB and adjustable progressive shift light	NO	NO	YES
4 RGB LED side lights which can be triggered by 3 different combined settings	NO	NO	YES
4 Virtual LED	YES	YES ⁶	NO
Diagnosis dashboard with real-time information of all inputs outputs, CAN and Status Events	YES		
Internal datalogger			
Multiple logs recording (channels)	256		
Configurable sampling rate per channel	1, 5, 25, 50, 100 or 200Hz		
Automatic activation by RPM, through the screen or by external button	YES		
Data storage for up to ⁵	2h50min		
FTManager Datalogger Software for viewing and comparing logs	YES		
Drag race features			
Burnout mode, 2-step, 3-step; Timing table for rev launch; 2-step by wheel speed or pressure/position of clutch; Time based RPM limiter by timing retard or ignition cut; Time based wheel speed or driveshaft RPM control with timing retard or ignition cut; Time-based ignition timing compensation; Pro-Nitrous setting for up to 6 stages, with activation control, fuel enrichment and ignition timing maps; Gear shift output; Time based output; Staging control; Wheelie control;	YES		
Other features			
Integrated GearController: ignition cut for clutchless gear shifting using a strain gage sensor on the shifter;	NO	YES	YES
Integrated BoostController: wastegate valve pressure control; Idle speed control by timing, step motor, PWM valve or electronic throttle body; Deceleration fuel cut-off; Control of up to two cooling fans by coolant temperature; Air conditioning control; Fuel pump control – with 6s prime; VTEC control; Progressive nitrous control with fuel enrichment and timing retard; Automatic transmission control; Lockup control; Launch delay control (Delay Box);	YES		
Protection and Alerts			
RPM limiter by fuel or ignition cut; Shift light ⁶ with sound and dashboard alert and/or external shift light; Configurable safe mode options;	YES		
General characteristics			
Display brightness adjusts; Night and day mode selection by external switch and through the menu; Audible and visual alert, including external shift light control; 5 memory positions to save different adjusts and maps; User and tuner protection passwords; PC communication through USB cable and channel customization via FTManager Software;	YES ⁶		
Working temperature:	-4 F until 158 F		
Maximum power supply	20V		
ECU Dimensions			
- ECU: width (in)	5.75	5.75	5.86
Height (in)	3.62	3.62	3.7
Depth (in)	2.13	2.13	2.42
- Box: width (in)	12.2		
Height (in)	8.86		
Depth (in)	3.34		
Weight			
- ECU (oz)	10	11	21
- Box with wire harness (oz)	92	134	117

1 - Recommended for high impedance injectors without the need of an external driver (up to 4 injectors per output)

2 - Recommended for ignition (open collector outputs with 5v power supply)

3 - Recommended for driving stepper motors, electronic throttle, ignition and 12v loads

4 - Use blue output number 6 as a 5th ignition output on FT450

5 - Data recording time depends on the sample rate and the number of channels that are being recorded.

6 - FT550LITE not support.

4.1 Harness connections A connector - FT450 / FT550 and LITE

Pin	Wire Color	Function	Information
1	Blue #1	Blue output #1	These outputs are usually used for injector control. When needed, they can be configured as auxiliary outputs ^{1 2 3 5} .
2	Blue #2	Blue output #2	
3	Blue #3	Blue output #3	
4	Blue #4	Blue output #4	
5	Blue #5	Blue output #5	
6	Blue #6	Blue output #6	
7	Black/white	Power ground input	Directly wired to the battery negative terminal with no seams. Do not tap any other grounds to this wire, it must run clean straight to the battery negative terminal.
8	Gray #1	Gray output #1	These outputs are usually used for ignition control. When needed, they can be set up as injector outputs or auxiliary outputs ^{1 4} .
9	Gray #2	Gray output #2	
10	Gray #3	Gray output #3	
11	Gray #4	Gray output #4	
12	Black	Battery negative input	Connected directly to the battery negative with no seams. Do not connect this wire to the chassis, engine block or head.
13	Red	12V input from relay	Connected to the pin 87 of the Main Relay
14	Green/Red	5V outputs for sensors	5V voltage output for TPS, electronic throttle and pedal sensors
15	Yellow/Blue	CAN A (-)	CAN A (-)
16	White/Red	CAN A (+)	CAN A (+)
17	Shielded Cable (white)	CAM sync signal input	Connected to the cam sync sensor (hall or magnetic)
18	Black Shielded Cable (White)	Magnetic RPM sensor reference	Connected to the negative wire of the magnetic sensor. When OEM ECU is reading the sensor in parallel, split this wire with OEM sensor negative - Do not connect when using hall effect sensor.
19	Black Shielded Cable (Red)	RPM signal input	Connected to the crank trigger sensor (hall or magnetic) or to the distributor. To VR sensors, use the shield wire the sensor shield. To Hall sensor, do not use the shield as negative
20	White #1	Input #1	Sensors input
21	White #2	Input #2	
22	White #3	Input #3	
23	White #4	Input #4	
24	White #5	Input #5	
25	White #6	Input #6	
26	White #7	Input #7	

1 - Outputs that can be used as "Tach output": Blue #3, blue #6, gray #4 (FT450)

2 - The blue output #6 can be used as the fifth ignition output (FT450)

3 - In order to avoid backfeeding when using the blue outputs or gray output #4 to power relays or actuators, make sure the switched 12V that powers them is the same that powers the ECU.

4 - When using as an injector output a Peak and Hold driver must be used

5 - The blue output #5 Can be used with PWM idle valve or WT Controller (FT450);

A-connector diagram - FT450 / FT550 and LITE

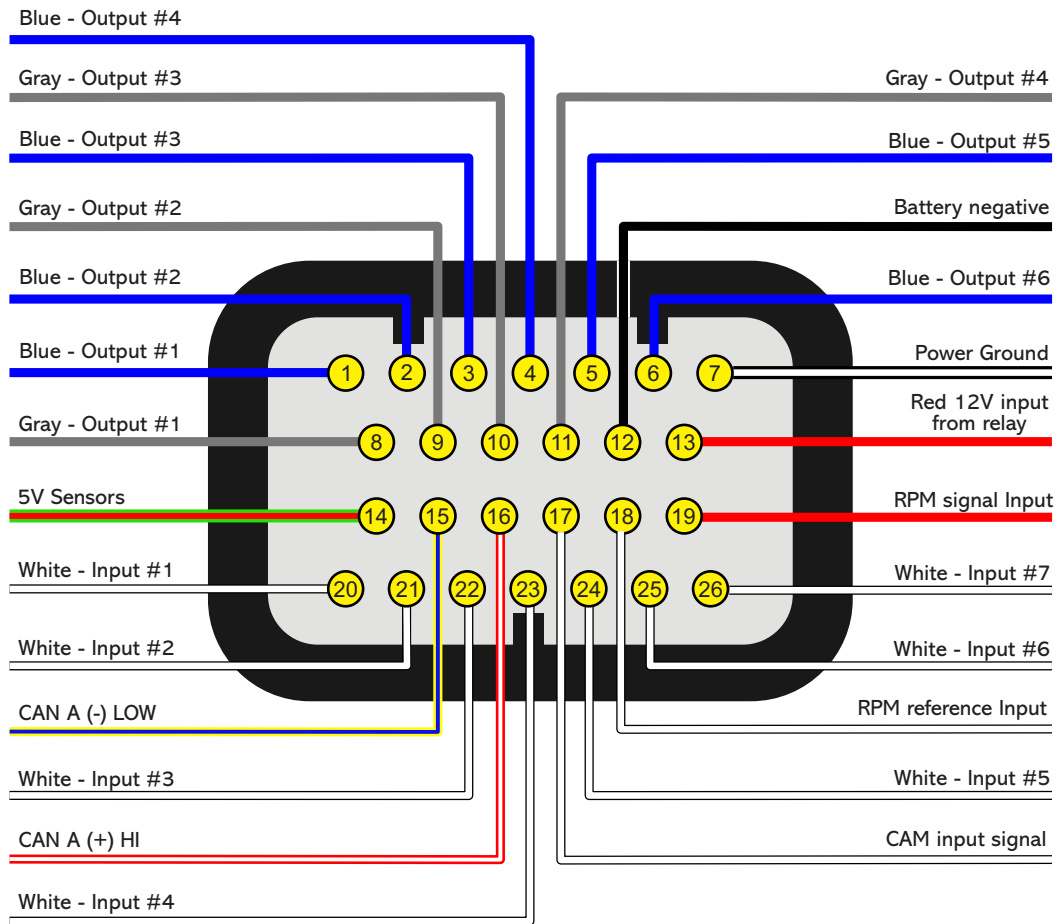

4.2 Harness connections B-connector (FT550 / LITE Only)

Pin	Wire Color	Function	Information
1	Black/White	Power ground inputs	Directly wired to the battery negative terminal with no seams. Do not tap any other grounds to this wire, it must run clean straight to the battery negative terminal.
2	Black/White	Power ground inputs	
3	Yellow/Blue	CAN B (-)	CAN B (-)
4	White/Red	CAN B (+)	CAN B (+)
5	White #8	Input #8	Sensors input
6	White #9	Input #9	
7	White #10	Input #10	
8	Blue #7	Blue output #7	These outputs are usually used for injector control. When needed, they can be configured as auxiliary outputs.
9	Blue #8	Blue output #8	
10	Gray #5	Gray output #5	These outputs are usually used for ignition control. When needed, they can be set up as injector outputs or auxiliary outputs.
11	Gray #6	Gray output #6	
12	White #11	Input #11	Sensors input
13	White #12	Input #12	
14	Blue #9	Blue output #9	These outputs are usually used for injector control. When needed, they can be configured as auxiliary outputs.
15	Blue #10	Blue output #10	
16	Gray #7	Gray output #7	These outputs are usually used for ignition control. When needed, they can be set up as injector outputs or auxiliary outputs ² . By standard, Gray output #8 is used as a tachometer output ¹ . (FT550)
17	Gray #8	Gray output #8	
18	White #13	Input #13	Sensors input or Power Shift Input - Blue wire Strain gage sensor (positive)
19	White #14	Input #14	Sensors input or Power Shift Input - Orange wire Strain gage sensor (negative)
20	Blue #11	Blue output #11	These outputs are usually used for injector control. When needed, they can be configured as auxiliary outputs.
21	Blue #12	Blue output #12	
22	Yellow #1	Yellow output #1	Electronic throttle and step motor outputs. Also used as injection or auxiliary outputs (cooling fan, fuel pump, etc.)
23	Yellow #2	Yellow output #2	
24	Yellow #3	Yellow output #3	
25	Yellow #4	Yellow output #4	
26	Green/Black	Ground for sensors	Connected the sensors ground

1 - In order to avoid backfeeding when using the blue outputs or gray output #4 to power relays or actuators, make sure the switched 12V that powers them is the same that powers the ECU.

2 - When using as an injector output a Peak and Hold driver must be used

B-connector diagram - FT550 / LITE

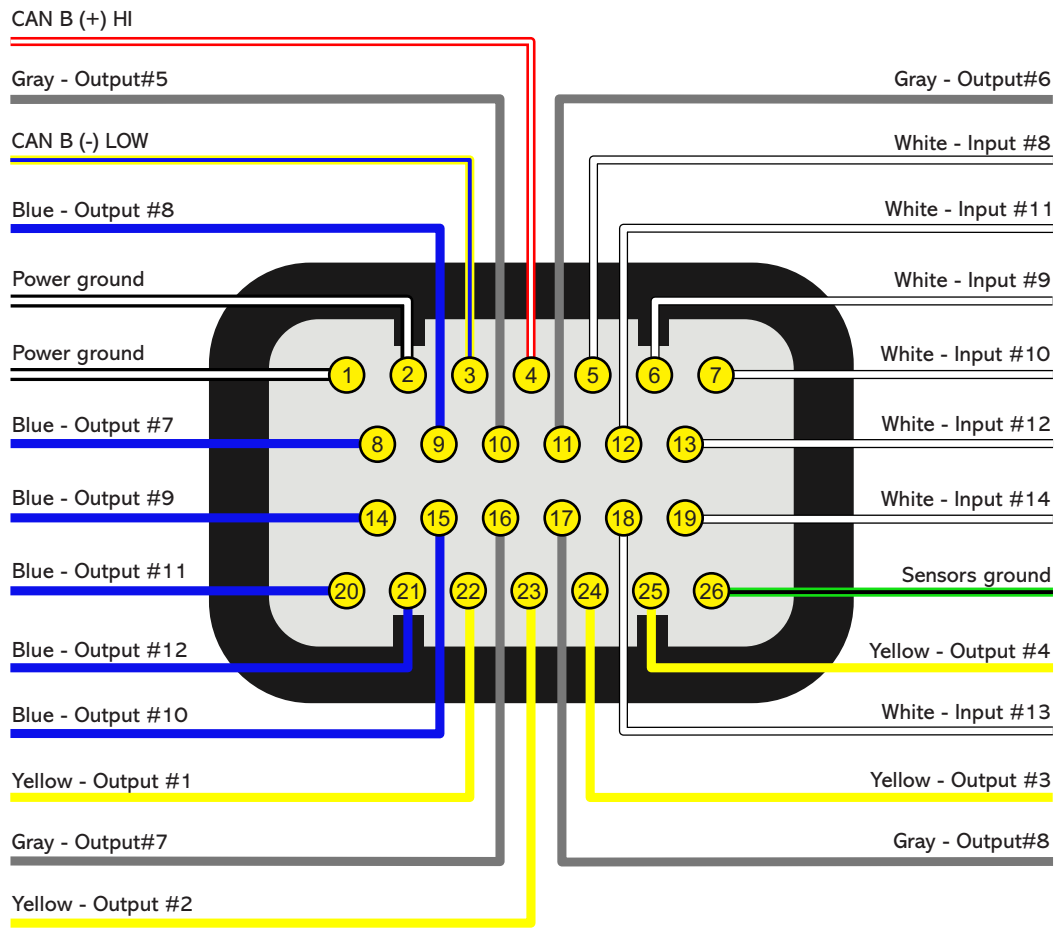

4.3 Harness connections A-connector (FT600)

Pin	Wire Color	Function	Information
1	Blue#1	Blue output #1	These outputs are usually used for injector control. When needed, they can be configured as auxiliary outputs.
2	Blue#2	Blue output #2	
3	Blue#3	Blue output #3	
4	Blue#4	Blue output #4	
5	Blue#5	Blue output #5	
6	Blue#6	Blue output #6	
7	Blue#7	Blue output #7	
8	Blue#8	Blue output #8	
9	Blue#9	Blue output #9	
10	Blue#10	Blue output #10	
11	Blue#11	Blue output #11	
12	Blue#12	Blue output #12	
13	Blue#13	Blue output #13	
14	Blue#14	Blue output #14	
15	Blue#15	Blue output #15	
16	Blue#16	Blue output #16	
17	Black/White	Power ground input	Directly wired to the battery negative terminal with no seams. Do not tap any other grounds to this wire, it must run clean straight to the battery negative terminal.
18	Gray#1	Gray output#1	These outputs are usually used for ignition control. When needed, they can be set up as injector outputs or auxiliary outputs. By standard, Gray output #8 is used as a tachometer output ¹ .
19	Gray#2	Gray output#2	
20	Gray#3	Gray output#3	
21	Gray#4	Gray output#4	
22	Gray#5	Gray output#5	
23	Gray#6	Gray output#6	
24	Gray#7	Gray output#7	
25	Gray#8	Gray output#8	
26	Yellow#1	Yellow output#1	Electronic throttle and step motor outputs. Also used as injection or auxiliary outputs (cooling fan, fuel pump, etc.)
27	Yellow#2	Yellow output#2	
28	Yellow#3	Yellow output#3	
29	Yellow#4	Yellow output#4	
30	Yellow#5	Yellow output#5	
31	Yellow#6	Yellow output#6	
32	Yellow#7	Yellow output#7	
33	Yellow#8	Yellow output#8	
34	Red	12V input from relay	Connected to the pin 87 of the Main Relay.

1 - The switched 12v on loads like relays and solenoids, must be the same as the ECU when being triggered by the gray output 8, to avoid backfeeding that will keep the ECU powered on (FT600)

A-connector diagram

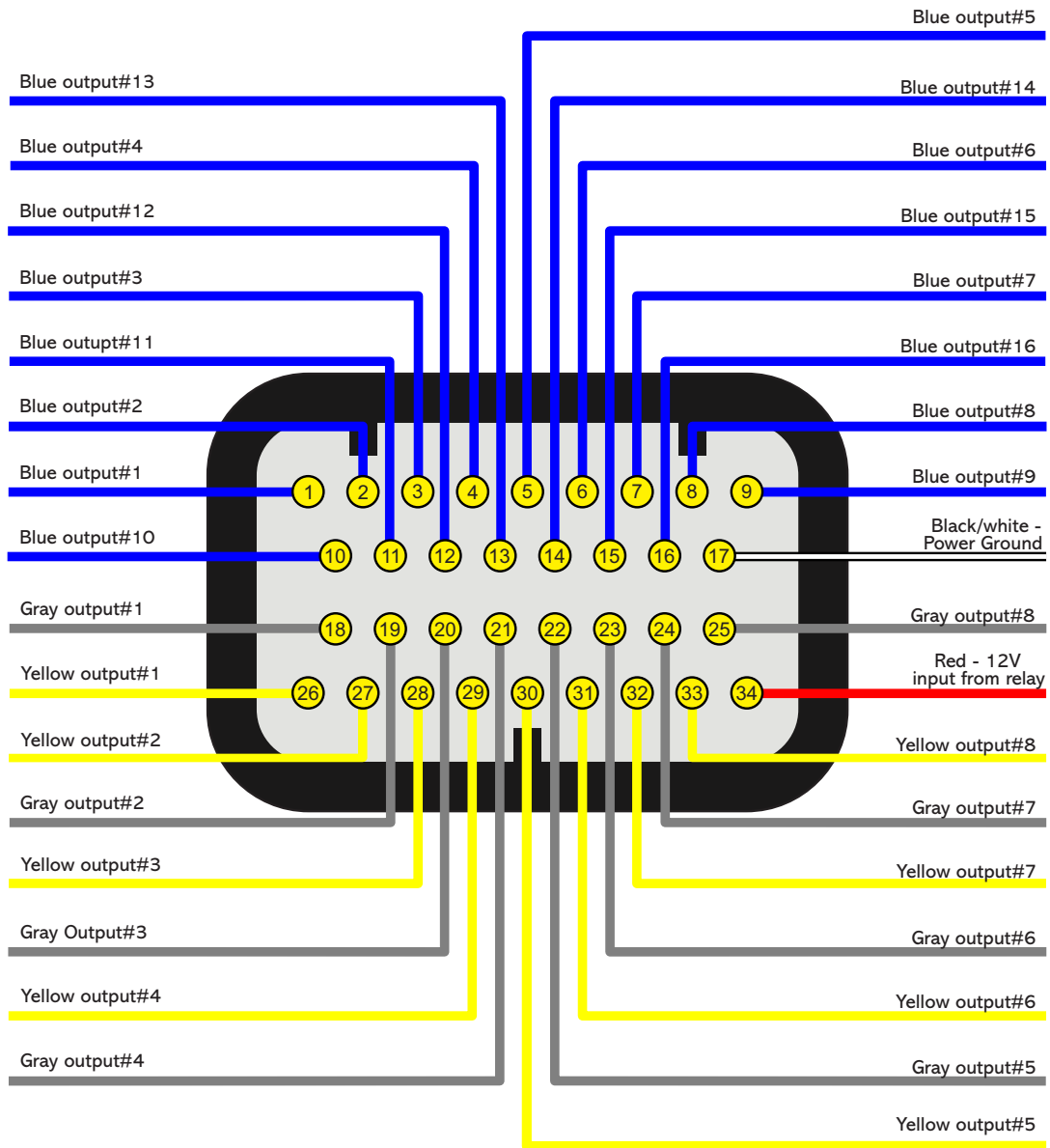

4.4 Harness connections B-connector (FT600)

Pin	Wire Color	Function	Information
1	Red	RPM signal input	Connected to the crank trigger sensor (hall or magnetic) or to the distributor. To VR sensors, use the shield wire the sensor shield. To Hall sensor, do not use the shield as negative
2	White	Magnetic RPM sensor reference	Connected to the negative wire of the magnetic sensor. When OEM ECU is reading the sensor in parallel, split this wire with OEM sensor negative - Do not connect when using hall effect sensor.
3	Red	Cam sync signal input	Connected to the cam sync sensor (hall or magnetic)
4	White	Cam sync reference input	Connected to the cam sync sensor (hall or magnetic) - Use the shield as negative to the sensor
5	White#1	White input#1	Default: O2 sensor input
6	White#2	White input#2	Default: two-step input
7	White#3	White input#3	Default: Air conditioning button
8	White#4	White input#4	Default: Oil pressure
9	White#5	White input#5	Default: Coolant temperature
10	Black	Battery negative input	Connected directly to the battery negative with no seams. Do not connect this wire to the chassis, engine block or head.
11	Yellow/Blue	CAN A LOW	CAN A
12	White/Red	CAN A HIGH	
13	White#6	White input#6	Default: fuel pressure
14	White#7	White input#7	Default: Air temperature
15	White#8	White input#8	Default: pedal#2 signal input
16	White#9	White input#9	Default: pedal#1 signal input
17	White#10	White input#10	Default: MAP signal output, electronic throttle 1B input signal
18	Black/White	Power ground inputs	Directly wired to the battery negative terminal with no seams. Do not tap any other grounds to this wire, it must run clean straight to the battery negative terminal.
19	Black/White		
20	White/Red	CAN B HIGH	CAN B HIGH
21	White#11	White input#11	Default: TPS sensor
22	White#12	White input#12	Sensors input
23	White#13	White input#13	
24	White#14	White input#14	
25	White#15	White input#15	
26	Red	12V input from relay	Connected to the pin 87 of the Main Relay
27	Green/Red	5V outputs for sensors	5V voltage output for TPS, electronic throttle and pedal sensors
28	Yellow/Blue	CAN B LOW	CAN B LOW
29	Green/Black	Ground for sensors	Connected the sensors ground
30	White#16	White input#16	Sensors input
31	White#17	White input#17	
32	White#18	White input#18	
33	White#19	White input#19	Power Shift Input - Blue wire Strain gage sensor (positive signal)
34	White#20	White input#20	Power Shift Input - Orange wire Strain gage sensor (negative signal)



NOTE

When using the GearController function connect the White wire from the shifter to ground for sensors Green/Black (pin #29).



IMPORTANT

Fuel only: When using this option, the RPM signal input cannot be connected to a coil high voltage signal because the input has no protection and will damage the trigger input on the ecu. Please use a tach output, another rpm source or an ignition coil to tach adapter module to avoid damage to the unit.

B-connector diagram

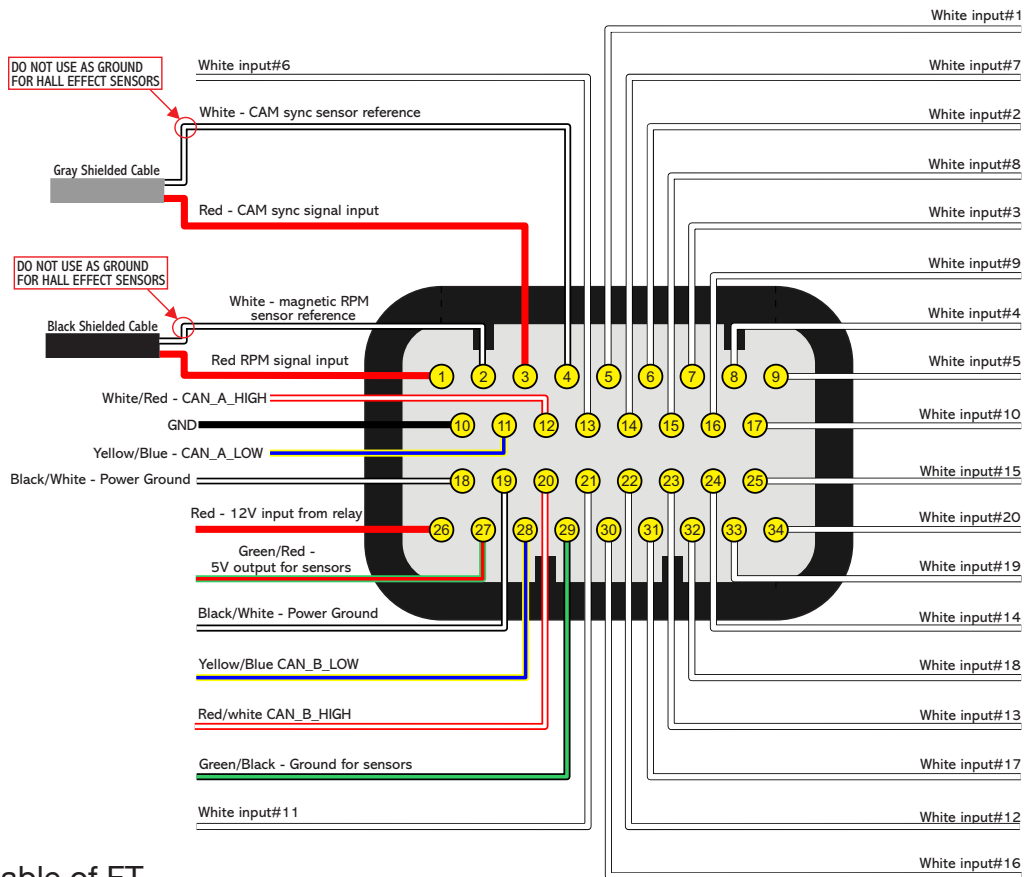

4.5 Output table of FT

Wire color	Output type	Nominal current for negative activation (0V) for each output	Nominal current for positive activation for each output	Application	Notes
Blue	Open collector (Lo side)	5A* ***	Can't activate by positive	Fuel injectors, relays, solenoid valves	Triggers loads always by negative
Gray	Open collector with current source in 5V (Lo side)	1A* ***	30mA in 5V	Inductive ignition control, fuel injectors, relays, solenoid valves	Triggers loads always by negative
Yellow	PUSH-PULL or HALF BRIDGE	5A* ***	5A** in 12V	Electronic throttle, step motor, MSD/M&W and other ignitions activated by 12V	When used to control relays, valves or any other load by negative , there is a risk of 12V return to the ECU. This will keep the ECU always powered on. In this case, an external diode or a relay with built-in diode is required for protection.
Green/Red	5V output	-	150mA in 5V	5V output sensors	Supplies 5v for sensors such as TPS, driveshaft, PS150, PS300 and etc...

* Total max current combined with all outputs triggering loads by negative: (30A - FT550 / LITE and FT600) (10A - FT450) continuous
 ** Total max current combined with all outputs triggering loads by positive: (20A - FT600) (10A - FT550) continuous
 *** Outputs can be automatically disabled for safety when currents above 20% of the rated current are detected



NOTE

Blue outputs cannot control ignition because they do not have a pullup resistor.



IMPORTANT

The ECU has the ability to support the connection of up to two relays at each output. If it is necessary to install additional relays, it is recommended to perform this installation in cascade, starting from the main relay.

4.6 PowerShift Connector (FT550 / LITE and FT600)

The FT600 wiring harness comes with the gear strain gauge sensor connector. In case the vehicle isn't equipped with a gear strain gauge, this connector can be removed and its white inputs can be used for other functions.

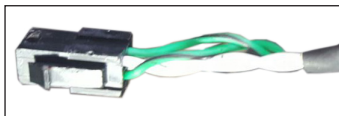

4.7 Auxiliary outputs

Outputs can be set up in many different ways, they have different capacities according to the function. Bellow is some important information about them:

Blue outputs: by default, used as injector outputs. Each one of them can control up to:

Impedance higher than 10 Ohms: 24 injectors for the FT550 and FT600/ 8 injectors for FT450 (amongst all blue outputs)

Impedance between 7 and 10 Ohms: 16 injectors for the FT550 and FT600/ 6 injectors for FT450 (amongst all blue outputs)

The use of a **Peak and Hold** driver is mandatory when the number of injectors is higher than the maximum quoted above or when using low impedance injectors (impedance below 7 Ohms).

During the Engine Setup configuration, blue outputs will be selected automatically.

When more than 16 injector outputs are needed, the ECU will use Gray outputs or Yellow output. In this case, the use of a Peak and Hold driver is mandatory on Gray and Yellow outputs (for saturated and low impedance injectors).

Blue outputs not used to control fuel injectors may be used as auxiliary outputs (controlling fuel pump, cooling fan, etc.). In this case, the use of a relay is mandatory.

Gray outputs: by default, used as ignition outputs. According to the engine setup, they can be set up as injectors or auxiliary outputs. During the Engine Setup configuration, ignition outputs will be selected automatically from Gray #1 to Gray #8 and from Yellow #1 to Yellow #4 (FT550) or Yellow #8 (FT600).

Gray outputs not used for ignition control can be set up as injectors outputs (the use of a Peak and Hold driver is mandatory) or as auxiliary outputs (the use of a relay is mandatory).

Yellow outputs (FT550/LITE and FT600 only): by default, they're used as electronic throttle control (Yellow #1 and #2) or stepper motor control (Yellow #1 to #4).

The yellow outputs that will not be used for electronic throttle control can be used as auxiliary outputs or for injectors. When using injectors for the integrated BoostController, the output can be connected directly to the injector, but when using injectors for fuel, the use of a Peak and Hold driver is mandatory for both high and low impedance injectors. This is because this output may present minimal differences in the injection time when controlling fuel injectors without Peak and Hold.

Tach output: There are some pre-defined outputs for this function, but in case the output for that is already assigned to something, use one of the following:

FT450: Gray 4 (Default) or Blue 3 or Blue 6

FT550/LITE/FT600: Gray 8 (Default) or any of the yellow outputs

4.8 Internal MAP sensor

This ECU is equipped with an internal MAP sensor. Use a **6mm pneumatic hose (4mm internal diameter)** to connect the sensor to the intake manifold. Pneumatic hoses are flexible, durable and highly resistant. Usually found in black or blue colors.

Silicon hoses are not recommended because they can be easily bent, blocking vacuum/boost readings on the ECU MAP sensor.

Use a hose exclusively for FT MAP sensor, avoiding splitting it with valves, gauges, etc. Connect it to any spot between the throttle and the engine head. Its length must be as short as possible to avoid lags and errors on the sensor readings. When using individual throttle bodies, it is a good idea to connect all intake runners into a single point and then connect to the FT MAP sensor; otherwise, MAP readings may be erratic or inaccurate.

4.9 USB port

The USB cable is used to update the ECU firmware version, setup maps and adjusts trough a computer and FTManager software and download data recorded by the internal datalogger.

4.10 FuelTech CAN network

FuelTech CAN port is a 4 way connector placed on the wiring harness of the ECU and is responsible for ECUs communication with other FT modules (GearController) and Racepak dashboards. A FuelTech CAN-CAN cable is used to establish a connection between them.



WARNING

For the correct operation of the CAN Network, its mandatory to use the CAN resistor as shown in the following image.

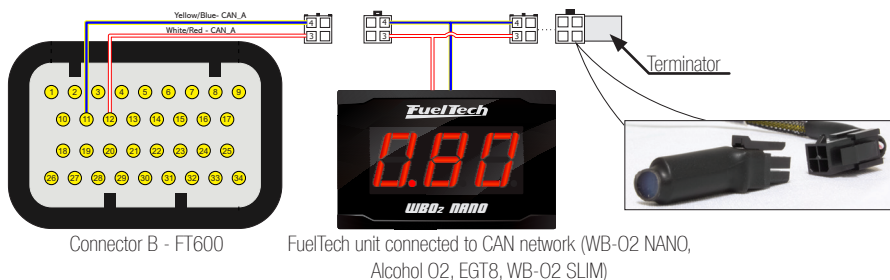

4.11 Connector disassembly

The connectors are built in a way that it's terminals can be easily taken out of the housing.

To do so follow these instructions:

- a - Remove the connector from the ECU
- b - Push down the white lock (1)
- c - Pull the wire (2) out of the connector
- d - On the other side of the connector, push down the 2 small white locks (3)

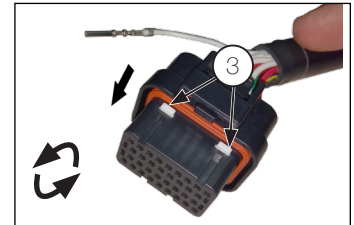
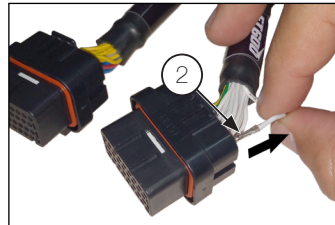

IMPORTANT

To ensure IP67 sealing of the module and electrical connector, do not remove any wires from the harness. The module seal is not affected, however the connector seal depends on the presence of wire and terminal inserted in its position. If you need to remove any wires, you must use a seal not supplied by FuelTech, part number 4-1437284-3

Using the connector with a vacant and unsealed terminal may allow water to enter and cause oxidation on the ECU terminals and electrical connector.

5. First steps with FuelTech read before installation

This chapter is a step-by-step guide that must be followed to start FT basic setup before electric installation, as the function of each wire may vary according to engine setup (number of cylinders, injectors control mode, ignition coils and auxiliary outputs).

1. Connect the flash drive in the PC USB port and install the FTManager software. Remember to check if the software and the ECU are in the latest version at www.fueltech.net.
2. Connect FT to the computer using the USB cable included on the package. The ECU will be powered up;
3. With the ECU in hands go through chapter 6, that introduces all basic information about menu navigation and operation;
4. Chapter 7 guides the user through all the menus where data regarding the engine must be setup (crank trigger signal, injectors and ignition control modes, etc.);
5. The last step before the electric installation is to check harness connections. Go to the "Engine Setting" menu then click the last option "Wiring harness diagram". Check and write down the connections and use it as guide to know how functions were allocated to the pins.
6. Chapters 8 to 14 guide through details related to the electrical installation of injectors, coils, 12V inputs, grounds, sensors, etc. Chapter 25 shows full wiring diagrams as example for your installation;
7. Chapter 15 gathers information on sensors settings for temperature, pressure, RPM, speed, etc.
8. With the electric installation finished, proceed to chapter 15.14 and check all the information needed for the first start of the engine, ignition calibration, sensors checking, etc.
9. Lastly, chapters 17 to 24 show detailed descriptions about all functions of the ECU. It is very important and informative to read these sections, as they also outline every function and operation that the FT can perform.

6. Getting to know the ECU

6.1 Dashboard

The ECU has a whole new dashboard, completely redesigned and customizable to improve visualization in any kind of vehicle.

- 1- **Top LED bar (shift lights only FT600):** configurable shift light by gear
- 2- **Side LEDs (alerts only FT600):** many different options of activation and alerts
- 3- **Dashboard:** fully customizable and redesigned with new gauges (3x2 size), besides a G meter



NOTE

For more info check chapter 23.11.



- 9 - **Interface Settings:** LCD backlight and alert sounds, dashboard configs, measurement units, touchscreen calibration serial number and version
- 10 - **File Manager:** Used to generate FuelTech Base Map, copy, delete and manager map files
- 11 - **Sensors and Calibration:** Setup and calibrate sensors, electronic throttle, O2 sensor, etc
- 12 - **Other Functions:** Internal datalogger, RPM limiter, fuel cut-off, thermatic fans, progressive nitrous, boost control idle speed, etc.
- 13 - **Drag Race Features:** Burnout mode 3-step, 2-step, spool assist table, Gear shift output, time based enrichment and timing Pro-Nitrous
- 14 - **Favorites:** Shortcuts to the most used menus and functions.
- 15 - **Diagnostic Panel:** Check inputs and outputs status and all information of what the ECU is reading and doing is real time



You can navigate through all menus with FTManager (available in the flash drive) and mini USB cable. The software initial screen is shown below:

6.2 Main menu

Navigation through touchscreen is intuitive, because the ECU display makes the access to information very easy, eliminating physical buttons. So, all changes on maps, setups and functions are done by light touches on the screen.

To enter menus, press the screen twice, just like a double click. This is a feature that prevents the user from entering the wrong menu when managing the ECU inside the car.

- 4 - **Dashboard:** Shows real time engine information (RPM, Temperature, pressure, timing, injection time, etc.)
- 5 - **Fuel Tables Adjust:** Main fuel map, overall fuel trim, RPM compensation, TPS idle fuel table accel fuel enrich and decay, engine and intake temp, compensation battery voltage, compensation, post start enrich, etc
- 6 - **Ignition Tables Adjust:** Main ignition map, overall ignition trim, MAP / TPS compensation, air and engine temperature compensations , individual cylinder trim, timing split, etc
- 7 - **Alert Settings:** Access to shift alert settings, safe mode RPM limiter, alerts by fuel and oil pressure, TPS, etc
- 8 - **Engine Settings:** Engine basics info as ignition mode, RPM signal, pedal/throttle settings, idle actuator, injectors deadtime, ignition dwell, wiring harness diagram

- 16 - Quick access
- 17 - Function table
- 18 - Help
- 19 - Function or map graph
- 20 - Real time dashboard

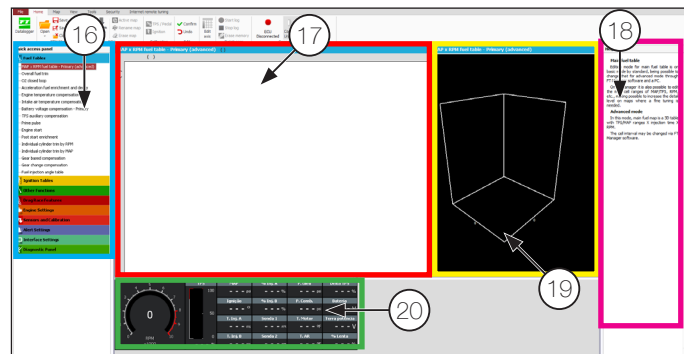

When entering a map or setting up a function, there are some buttons on the screen that act as described below:

- 21 - Red area shows the point selected for editing
- 22 - Yellow area is shown only when the engine is running and shows the actual condition of MAP, temperature, TPS, etc

- 23 - Button +:** increases the value of the selected parameter
- 24 - Button >:** Selects next parameter on the map
- 25 - Save/Select Button:** Saves any changes done to the map or configuration and returns to the main menu
- 26 - Home Button:** Returns to the home screen. If any maps or configurations were changed, it ask for confirmation
- 27 - Cancel/Back Button:** Cancels all changes done to the maps or configuration and returns to previous menu
- 28 - Button -:** Reduces the value of the selected parameter
- 29 - Button <:** Selects previous parameter on the map
- 30 - Button <>:** Change the screen (if available on the menu)

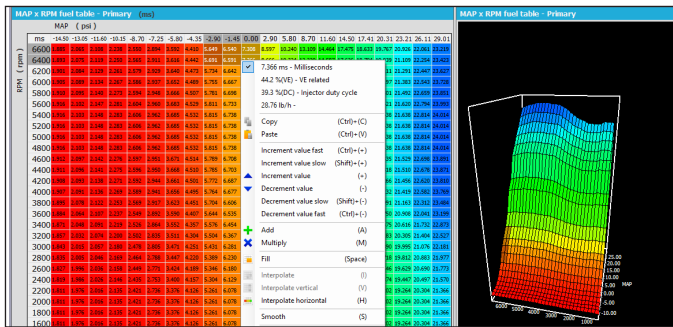
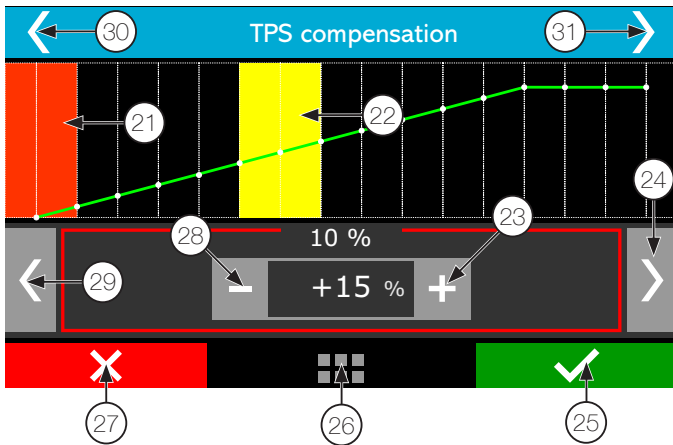

In the FTManager all commands are accessible through mouse and keyboard. The advance (3D) fuel table is shown below:

Advanced edition mode

In the advanced mode, both fuel and timing tables will be in a 3D table format. Some functions will also be presented in a 3D table only. The navigation is very simple, in the left bottom corner you can see the current position in the table. Green marker is for bank A and purple for bank B. A yellow marker will show the current engine table position. If you click this icon, you will taken to the current load/tps and rpm position.

To scroll through the vacuum/pressure or TPS, click in the horizontal direction of the table, to RPM ranges, click in the vertical direction.

- 31 - Injector Bank**
- 32 - Engine RPM**
- 33 - MAP / TPS**
- 34 - Use button + and - to increase or decrease injection time**
- 35 - Injection time and percentage. The above value corresponds to bank A value below to bank B**

36 - Table position mini map:

- Yellow:** click this icon to go directly to the point of the map where the engine is working at the moment
- Purple:** That's the position of the table that's being shown by the screen

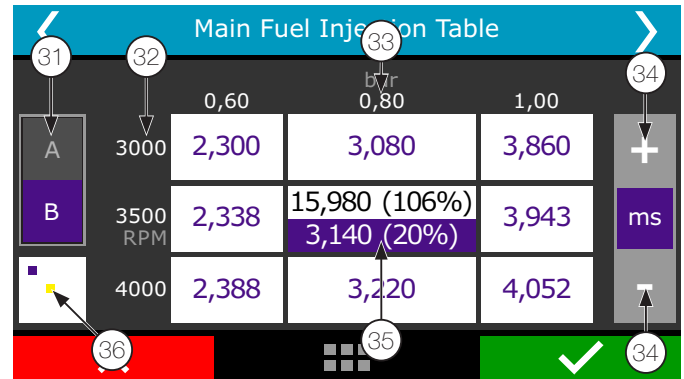

6.3 FTManager shortcuts

- **F1** – Show and hide help panel
- **F2** - Show and hide quick access panel
- **F3** – Show and hide graph
- **F4** – Show and hide real time (FTManager real time dashboard)
- **F5** – display main table and hide every other function
- **F6** – change the main fuel table measurement unit: milliseconds (ms), volumetric efficiency (%VE), duty cycle (%DC), fuel flow (lb/hr or customized unit)
- **F7** - Datalogger REC
- **F8** - Datalogger Stop
- **F9** – no shortcut
- **F10** – datalog overlay - vertical split screen
- **F11** – datalog overlay - horizontal split screen
- **F12** - Dashboard popup
- **(Ctrl) + (C)** – copy
- **(Ctrl) + (V)** – paste
- **(Ctrl) + (+)** – fast value increment. Increases 0,100ms in the fuel table. On VE and DC the change is related to milliseconds
- **(Ctrl) + (-)** – slow value decrement. Decreases 0,100ms in the fuel table. On VE and DC the change is related to milliseconds
- **(+)** – Increment in 0,010ms steps. On VE and DC the change is related to milliseconds
- **(-)** – Decrement in 0,010ms steps. On VE and DC the change is related to milliseconds
- **(Shift) + (+)** – slow value increment in 0,001ms steps. On VE and DC the change is related to milliseconds
- **(Shift) + (-)** – slow value decrement in 0,001ms steps. On VE and DC the change is related to milliseconds
- **(A)** – sum
- **(M)** – multiply
- **(Space bar)** – pops up a box to fill a value
- **(I)** – interpolate the selected cells
- **(V)** – interpolate vertically the selected cells
- **(H)** – interpolate horizontally the selected values
- **(S)** – Smooths the fields selected in the main tables
- **(G)** – site function. Moves the cursor to actual engine position

- **(Home)** – moves the cursor to the leftmost cell
- **(End)** – moves the cursor to the rightmost cell
- **(Page Up)** – moves the cursor to the topmost cell
- **(Page Down)** – moves the cursor to the bottommost

6.4 Warning sounds in FT550LITE

The FT550LITE has several warning sounds that indicate error conditions, safety alerts or gear shifting rpm. Check out the meaning of these alerts:

Short duration alert at short intervals (40 ms with sound, 10 ms without sound)

- Shift alert: the alert turns on at a programmed rpm.

Average duration alert at short intervals (400 ms with sound, 100 ms without sound)

This warning refers to any safety configuration inserted in the Alerts Settings menu

It can refer to:

- Over rev / Injector duty cycle / Overboost / High oil pressure / Low oil pressure / Minimum oil pressure @ RPM / High engine temperature / Low fuel pressure / Base fuel pressure /

The alert will only sound if the function is enabled at the Alert Settings menu.

Long duration alert with average intervals (800 ms with sound, 400 ms without sound)

This alert may correspond to different situations in ECU:

ECU firmware error: (need to update the module via the FTUpdater);

Missing cam sync sensor: a setting was sent to the module which requires the use of cam sync sensor (12 teeth crank trigger and sequential ignition). In this case, go to the RPM Signal menu and enable the cam sync sensor;

Ignition must be configured as a distributor: a configuration has been sent to the module that only works in distributor mode. In this case, connect the module to the PC and go to Ignition menu and select the “Distributor” option;

Disabled outputs: connect the FT550LITE to the PC, go to the Engine Setup menu and select the check box “Enable Outputs pins”;

TPS not calibrated: connect the module in USB and calibrate the TPS before starting the engine;

These alerts will be played continuously and will only stop when the error condition ceases to exist.



IMPORTANT
 When connecting FT550LITE to the USB, it is normal that the warning sound is weak. It is a strategy to save the battery when connecting the ECU to notebooks.

6.5 Dashboard screen

When the engine is running, the dashboard screen shows real-time information of sensors that are being read by the ECU.

Chapter 23.3 has more information on how to change the instruments on this screen.

To access the dashboard screen, touch the icon , located at the main menu.

- 1 - Real time readings;
- 2 - Internal datalogger status;
- 3 - Touch this whole area to access the main menu;
- 4 - Accelerometer graphic;

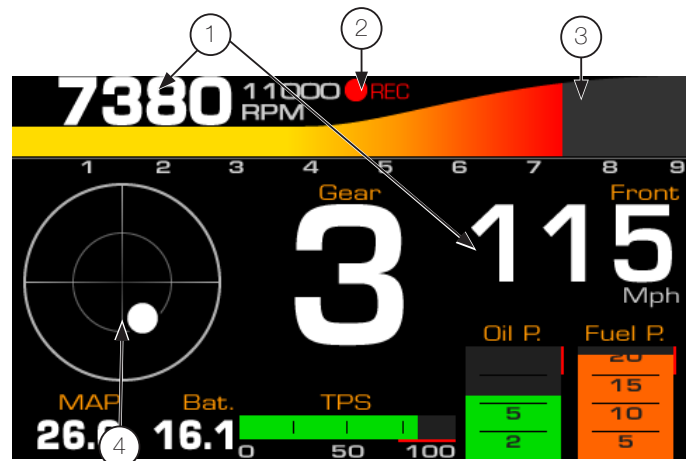

The dashboard is also shown in real time in FTManager:

To add or remove gauges, click with mouse right button in a free space and select the gauge type you want to (radial, bar or digital).

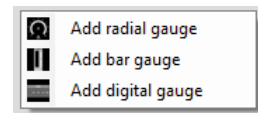

6.6 Diagnostic panel

The diagnostic panel is a function which shows all ECU inputs and outputs parameters and is very helpful to detect anomalies in tune, sensors and actuators. To access it through FTManager, click on Diagnostic Panel tab at quick access panel.

The Diagnostic Panel is a tool used to detect anomalies on inputs, outputs, sensors and actuators. In order to access it, touch its icon , at the main menu.

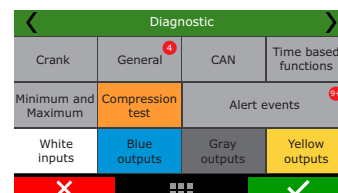

The diagnostics panel is separated in the following screens:

Crank	General	CAN	Time functions
Minimum and maximum	Compression test	Alert event	
White inputs	Blue outputs	Gray outputs	Yellow outputs

In this screen a small red circle with a number inside is shown in the corner of the icon when there's a problem on that function.

Crank

Displays crank and cam RPM as well as cam sync angle, very useful for diagnosing problems in cam and crank trigger sensors.

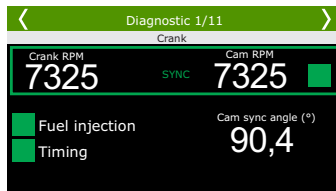

General

Displays real time information of all the sensors and engine conditions.

Inputs, outputs and CAN

White inputs: in the left, the function assigned to the input is displayed, in the center is the voltage being received by the wire and in the right the value corresponding to that reading.

CAN bus: In the left the name of the sensor is displayed and in the right, the reading of said sensor.

Blue, Gray and Yellow outputs: In the left is the name of the function assigned to the output, in the center is the applied value, and in the right, data relevant to the performing of the function.

Minimum and maximum

Displays the peak maximum and minimum values recorded by the ECU during it's usage. These values can be erased by touching the red X icon lower right corner of the screen or in "Interface Settings/ Erase Peaks".

On page 10 are information regarding the engine RPM readings. Below are some common errors and possible causes:

Crank trigger error: gap detected at the wrong spot - it detected the gap (missing teeth) in the wrong place; it can also happen with a trigger wheel without missing tooth when there is a cam sync signal in the wrong place. Also occurs in engines with a very light flywheel that accelerates and decelerates quickly during compression strokes at engine startup and running.

Crank trigger error: wrong number of teeth - number of teeth is different on the crank trigger wheel than what is set at ECU. Electrical noise can cause a reading of a "ghost" tooth, for example.

Crank trigger error: missed tooth reading - the ECU detected less teeth then it should have. Also happens in engines with a very light flywheel that accelerate and decelerate very fast during compression strokes at engine startup and running.

Crank trigger error: abnormal acceleration - tooth error detection. Usually caused by signal noise.

Cam sync sensor: signal noise - cam sync signal detected in the wrong spot. Typically this error is caused when the ECU detects noise in the cam sync sensor signal or when the cam trigger wheel has more than one tooth.



WARNING
 When the 2-step and 3-step are set to activate by speed, its operation can be checked through the page 1 of the Diagnostic Panel, not through page 2, since you are not using an analog input (white wire) to switch.



Diagnostic panel labels

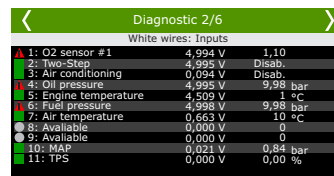

	Input or output is configured, enabled and working properly.
	Input or output is configured and disabled.
	Input or output has not been set up.
	Input or output is set up, but there is an abnormal behavior.

6.7 Test time based features

This menu allows you to run the output test controlled by time. To start this test the engine must be turned off and the ignition switch on (12V). The test starts when the 2-step button is pressed and lasts as long as the button is pressed.

While the test is performed the RPM values, MAP, TPS and temperatures can be changed in real time.

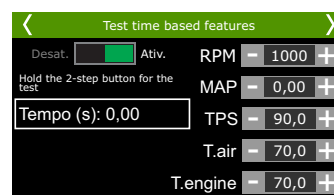
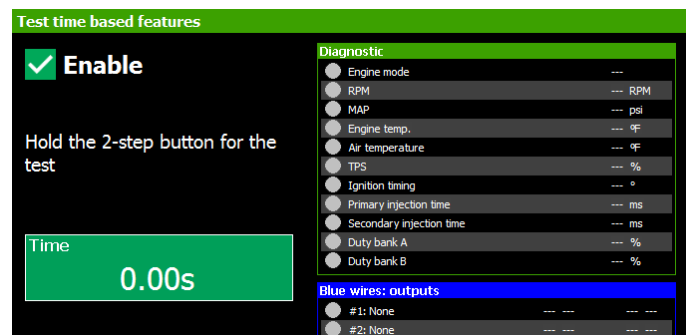

6.8 Compression test

The compression test monitors the current during the engine cranking to estimate the relative compression in each cylinder.

The battery current increases during each cylinder compression stroke, reducing the battery voltage.

The test is performed through the ECU screen, at the "Diagnostic Panel/Compression Test"

The test is performed during the engine cranking, injectors and coils will be disabled during the test. The ECU screen will show the relative compression in each cylinder.

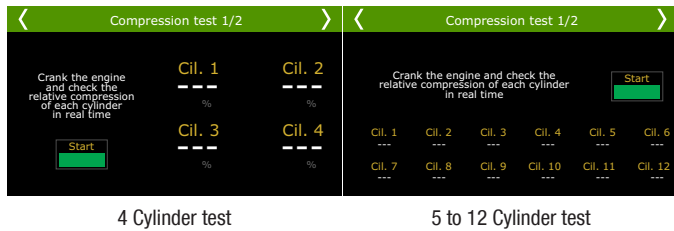

6.9 Internet Remote Tuning

Since update 3.3, FTManager has a new feature which will make it easier to connect 2 computers that have FTManager installed.

To start a connection go to the "Internet Remote Tuning" tab on FTManager.

Allow remote tuner: This option allows for another remote computer to connect to your FTManager. Click on "Allow" to generate a 6 digit password which must be informed to the tuner that's going to connect to your computer.

Tune remote client: This option allows you to connect to another remote computer using the 6 digit password generated on the client's FTManager.

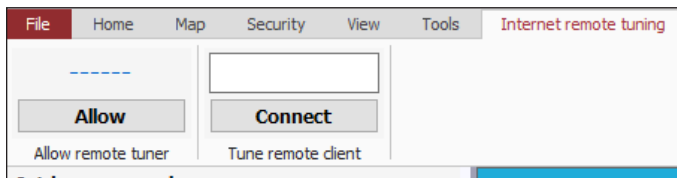

6.10 FTManager exclusive features

This section will explain some features that can only be found in the FTManager, they make it easy to create new map files based on existing ones.

1 - Import settings: settings from another map can be imported to the currently opened map.

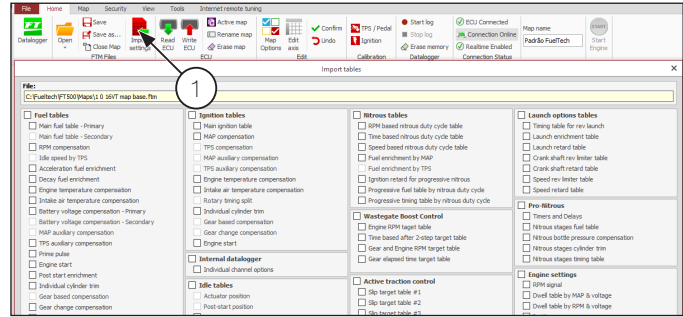

2 - Import from ECU Manager: Use this option to import settings from maps from FT200, FT250, FT300, FT350 and FT400 into a map in FTManager.

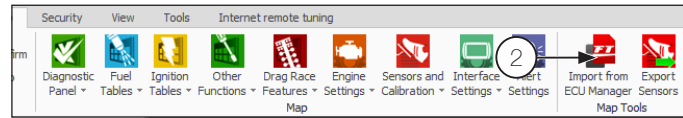

3 - Export sensors: export sensors from this map into another one.

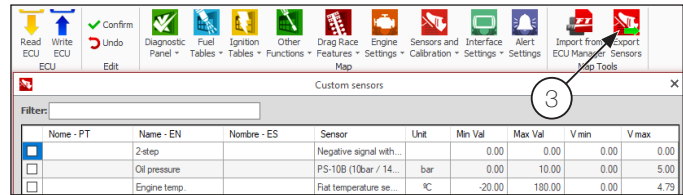

4 - ECU factory reset: Performs a factory reset and completely erases maps and settings on the ECU.

5 - Project CARS Interface: Use this option to send data from the Project CARS game to the ECU and use it as a dashboard.

6 - Refresh Throttle database: Update the compatible electronic throttle database on the software.

7 - Check Updates: Checks if a newer version of the software is available.

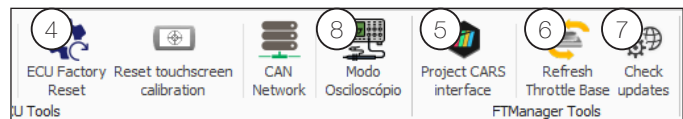

8 - Oscilloscope mode: Used to diagnose RPM and Cam Sync signals.

Oscilloscope mode

This tool allows the RPM and Cam sync signals received by the ECU to be drawn on screen and analyzed by the user to find any issues that can make engine start difficult as well as RPM signal losses.

By analyzing the signals, it's possible to identify damages in the trigger wheel, as well as the pattern (number of teeth), problems with the sensor itself, and the best working trigger voltages.

To access this function, go to "Tools" and then "Oscilloscope Mode".

There are several signal display configurations.

Frequency (Hz): adjusts the frequency that the signal is shown in a range from 1KHz to 500 KHz.

Axis Y: adjusts the voltage limits shown in the graphic from 2.5V to 25V.

Export to: This log file can be exported as text format, Excel spreadsheet or as an image.

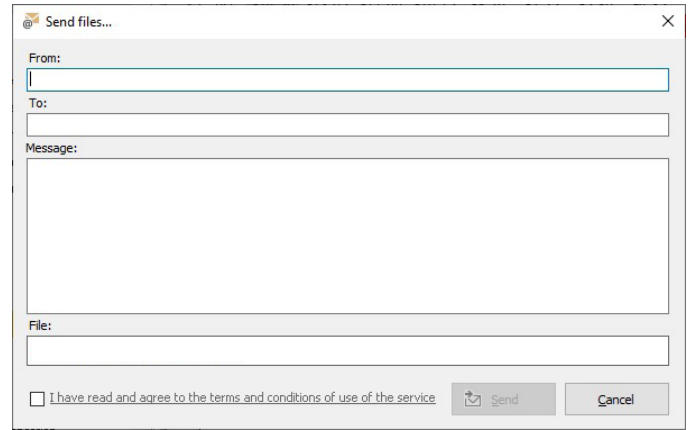
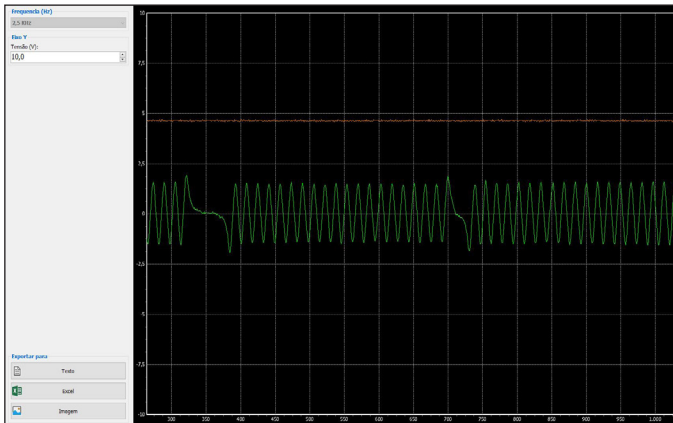

Engine Simulator (9)

Now it's possible to change reading values from sensors and activate buttons from certain features to simulate engine operation and test actuators and solenoid response while the engine is OFF. Recommended to test the overall behavior of electronics in the engine and car;

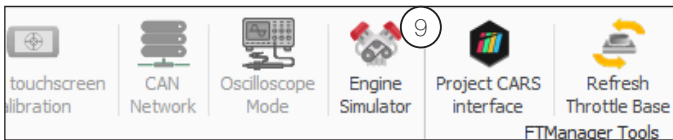

Send Map (10)

This option allows you to send the map directly via FTManager, click on the "send map by e-mail" button.

From: enter your email or your name;

To: enter the email to whom you want to send the map;

Message: Write your message, describing the subject of the email;

File: the map that is currently open will be attached.

To send it is necessary agree to the terms and conditions of use of the service.



NOTE

The computer must have access to the web, to send the map by e-mail,

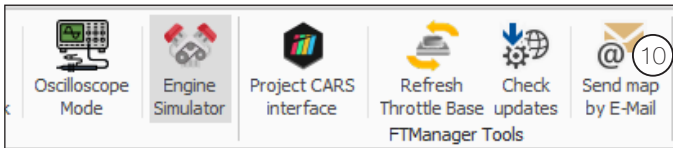

Input expander (11)

Input expander to PowerFT ECUs see owner manual for more information

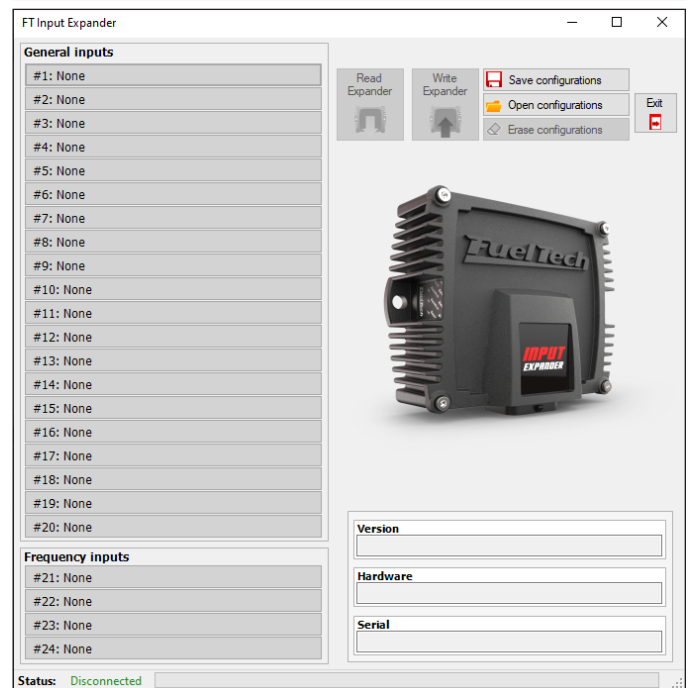
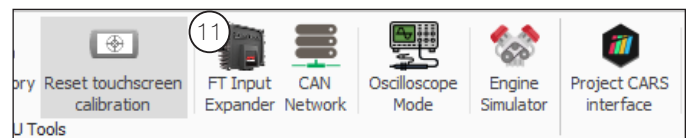

6.11 FTManager - Datalogger

Used for a complete analysis of datalogs recorded in the ECU, refer to chapter 19 for instructions on how to set up which channels are going to be recorded.

- 1 - **Options:** Here the channels of the opened log can be edited without changing the settings of the map file.
- 2 - **Set zero time:** Use this to set the 0 mark of the timer, can be assigned right at the launch so the run gets properly timed in the log.
- 3 - **Clear all graphs:** hides all channels.

- 4 - **Compare graphs:** Compare graphs between 2 or more logs.
- 5 - **Min/Max values:** List all the minimum and maximum values registered for each channel.
- 6 - **Status events:** Displays an alert and error report along with the time at which they occurred.
- 7 - **Log info:** This form should be filled by the tuner with information regarding track times, weather, driver and many others that pertain the opened log file.

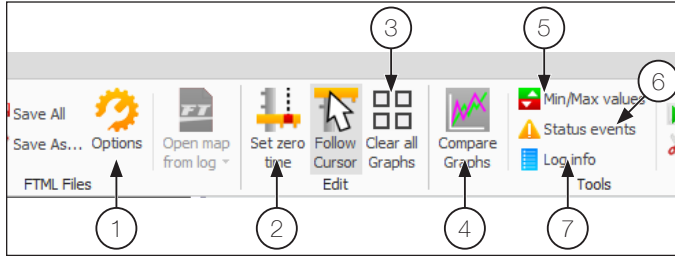

8 - **Fuel table Overlay:** making it possible to see which cells were in use as you drag the cursor through the log file.

9 - **Ignition table Overlay:** making it possible to see which cells were in use as you drag the cursor through the log file.

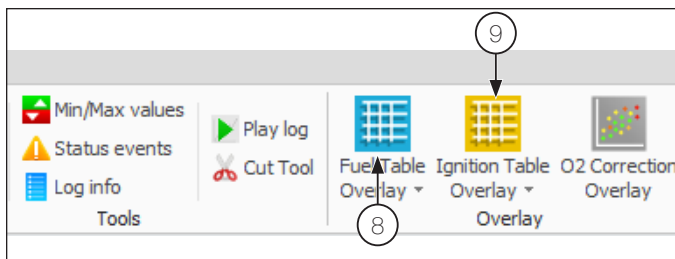

10 - **O2 correction overlay:** This features works similarly to the regular fuel table overlay but, besides showing all the corrections performed by the O2 closed loop, it makes it possible to apply changes permanently to the fuel tables by clicking "send to FTManager".

To apply the O2 closed loop corrections follow these steps:

- a) Open the datalog file to be analyzed
- b) Click on O2 corrections overlay (10)
- c) A screen will pop up showing corrections made to the fuel table of the currently opened map(not the one from the datalog, so make sure the log file being analyzed was made using the same map file that is currently opened in the software)
- d) Analyze the colored cells and select the values to be sent to the map and click "send to FTManager"

For better results, it is recommended that the log files are recorded with similar conditions of temperature, RPM, boost, weather, etc.

As this feature does not change temperature compensation tables (IAT and ECT), the O2 closed loop compensation will be directly affected by them and may apply corrections that are not necessarily the best for your fuel table.



NOTE

- **This feature will only work on 3D maps**
- **The correction can be applied as many times as desired, the more it is used, the better the fuel table will get.**

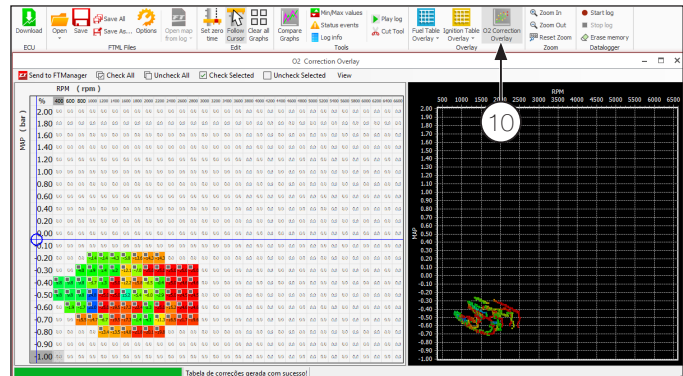

7. Engine settings

FuelTech ECUs leave the factory without maps or adjustments, so you need to create the injection maps, ignition and the inputs and outputs settings before running the engine.

The FuelTech Default is an automatic calculation of the basic injection and ignition maps for your engine based on the information provided in the "Engine Settings". Performing this automatic adjustment every injection and ignition maps, including temperature compensation, etc. Will be filled based on your engine characteristics.

The information provided must be correct and consistent, maximum RPM and boost values should be according to the engine capacity and the injectors should be properly sized to the estimated engine power.

The use of an instrument, such as oxygen sensor (wideband recommended) and/or an analyzer of exhaust gases, to make the analysis of the air/fuel mixture is extremely important.

Caution, especially during start-up, is needed, since it is an initial tune that will start most engines, there are no guarantees for any situation. Be extremely cautious when tuning your engine. Engine should not be operated at maximum load until the air fuel ratio has been confirmed.

Start tuning with a rich map and a conservative timing, because starting with a lean map and advanced timing can severely damage the engine.

To create a default map by FTManager, click the "File" menu and then "New" to start the wizard. The menu "Engine Settings" will be passed in sequence.

Check in later chapters the descriptions of all these options required to complete the step by step and create the default map.

Vehicle mode

There are three modes, combustion, electric and hybrid

Combustion: Enable this function for conventional combustion engine control, powered by Ethanol, Methanol, Gasoline and derivatives.

Electric: Enable this function to use only the electric motor control, all other functions for combustion engines will be hidden to facilitate the use of the equipment.

Hybrid: Enables all functions for electric and combustion control.

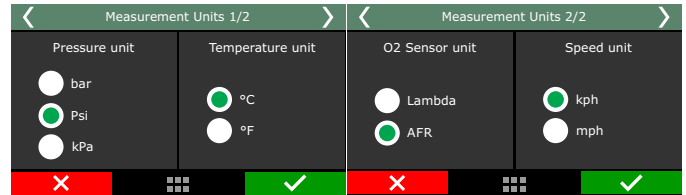

7.1 Engine setup

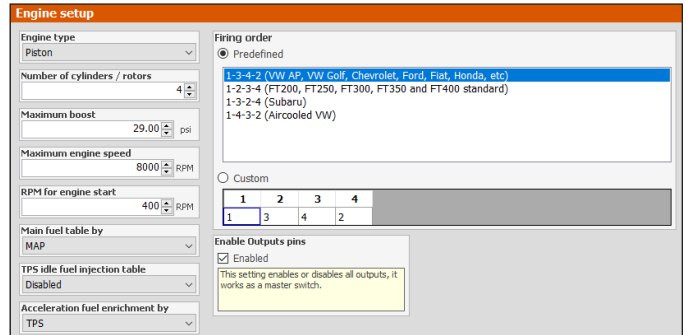
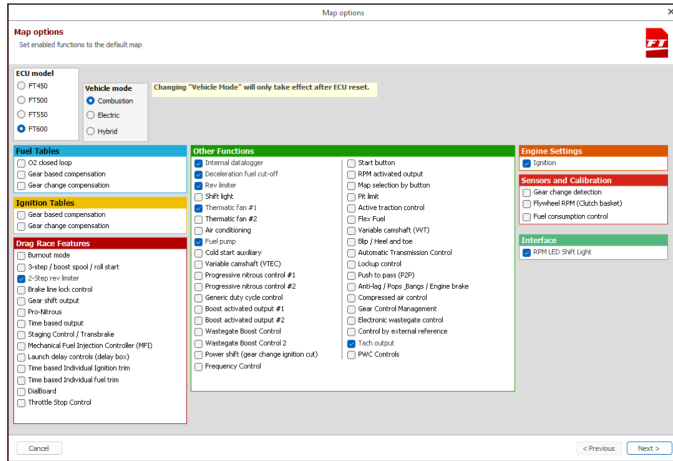

Enable outputs

Basically prevents the outputs from turning on (injection, ignition and auxiliary outputs).

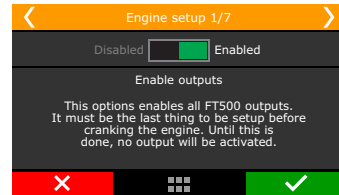

Engine type and number of cylinders

Select the type of engine, piston or rotary and the number of cylinders or rotors.

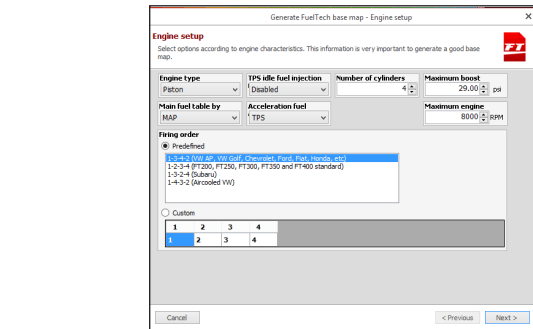
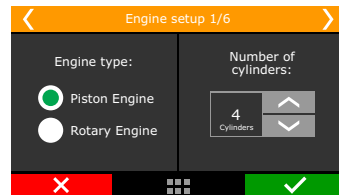

To generate a new map through the touchscreen, just get in a setting that is empty and a message appears telling you that the setting is empty and asking if you want to create a new tune.



In the first screens of the wizard are the settings for measurement units used by the ECU. Select the temperature, O2 sensor, pressure and speed units.

The following screens are part of the engine configuration menus and are described in the following chapters. Follow the wizard by reading the next pages.

Engine limits

Setup the maximum RPM and maximum boost.

Maximum engine speed: setup the engine maximum RPM. All fuel and timing maps will be created with its last point on this RPM. This parameter is also used to calculate fuel injector's percentage of use.

Maximum boost: maximum boost for fuel and ignition maps. For naturally aspirated engines, set this option as 0.0psi. For turbocharged engines, use 10psi above the maximum boost the engine will effectively be using. In case of an overboost, the ECU will apply the last injection timing set on the map. This option doesn't control boost pressure, is just a limit for fuel and ignition maps.

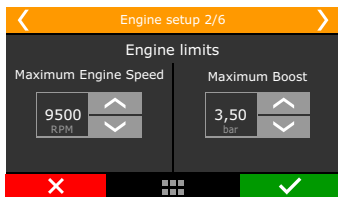

Firing Order

Select the firing order according to your engine.

4 cylinder engines

- 1-3-4-2: majority of engines, VW AP, VW Golf, Chevrolet, Ford, Fiat, Honda, etc.;
- 1-3-2-4: Subaru;
- 1-4-3-2: air-cooled VW;
- 1-2-4-3: Motorcycles (majority)

5 cylinder engines

- 1-2-4-5-3: Audi 5 cylinders, Fiat Marea 20V and VW Jetta 2.5;

6 cylinder engines:

- 1-5-3-6-2-4: GM in line (Opala and Omega), VW VR6 and BMW in line;
- 1-6-5-4-3-2: GM V6 (S10/Blazer 4.3);
- 1-4-2-5-3-6: Ford Ranger V6;

8 cylinder engines:

- 1-8-4-3-6-5-7-2: Chevrolet V8 (majority);
- 1-8-7-2-6-2-4-3: Chevrolet LS
- 1-5-4-2-6-3-7-8: Ford 272, 292, 302, 355, 390, 429, 460;
- 1-3-7-2-6-5-4-8: Ford 351, 400 and Porsche 928;
- 1-5-4-8-6-3-7-2: Mercedes-Benz;

10 cylinder engines

- 1-10-9-4-3-6-5-8-7-2: Dodge V10;
- 1-6-5-10-2-7-3-8-4-9: BMW S85, Ford V10, Audi, Lamborghini V10;

12 cylinder engines

- 1-12-5-8-3-10-6-7-2-11-4-9: Jaguar V12, Audi, VW, Bentley Spyker W12;
- 1-7-5-11-3-9-6-12-2-8-4-10: 2001 Ferrari 456M GT V12;
- 1-7-4-10-2-8-6-12-3-9-5-11: 1997 Lamborghini Diablo VT;

Customized

- In case the firing order of your engine is not listed on the ECU, there's a mode that allows full customization of the firing order.

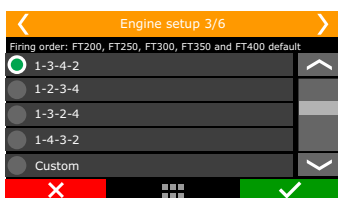

Main fuel table

MAP: this mode is indicated for turbo or naturally aspirated engines. That's the mode that better represents engine load, because engine vacuum varies under different loads, even with the throttle on the same position.

TPS: this option is mostly used on naturally aspirated engines with aggressive camshafts, when this causes the vacuum on idle and under low load conditions to be unstable. When this option is selected, MAP compensation is available for fuel and timing maps.

TPS idle fuel injection table: This is the mode the fuel injection on idle speed will be controlled. When enabled, a table that relates injection time versus engine RPM is activated whenever TPS is equal to 0%. Enable this feature on engines with high profile camshafts and unstable vacuum on idle.

For street cars with stable vacuum on idle, it is recommended to keep this feature disabled. In this case, injection time for idle will be set up directly on the vacuum ranges on the main fuel MAP.

Accel fuel enrichment: use this parameter set up as TPS whenever possible, as this sensor reacts faster than the MAP sensor to indicate a quick change of position in the throttle.

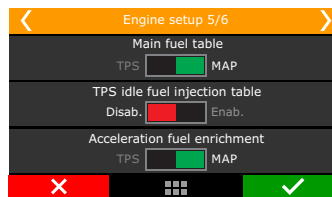

RPM for engine start: set up a RPM limit above which the start-up routines are disabled. Below this RPM, all the injection, ignition and actuator positions set up for engine start are used.

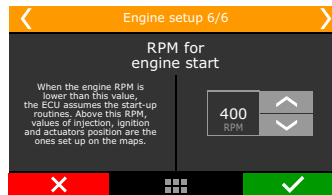

BSFC: ESTIMATED number of engine efficiency to be used in ESTIMATED crankshaft torque and power. Total injector flow information, BSFC or incorrect AFR will result in inconsistent power and torque values.

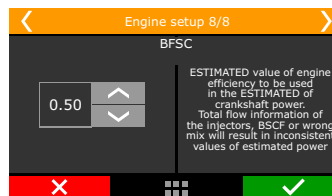

7.2 RPM signal

RPM signal is the most important information to run the engine properly. This menu is where the RPM input will be set up.

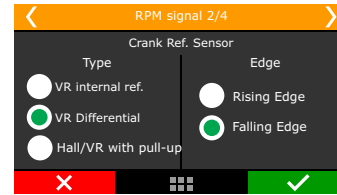
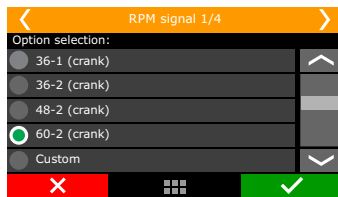
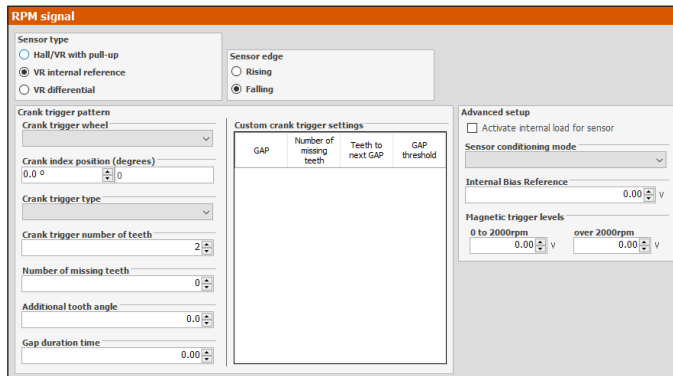

WARNING
Ignition calibration values on this table are just a start point. ALWAYS perform the ignition calibration according to chapter 16. When the ignition is not correctly calibrated, the timing shown on the ECU screen is different from the one that is being applied to the engine. This may cause serious damage to the engine.

Engines with crank trigger: select the crank trigger pattern.

Select the crank trigger or distributor pattern. In case of a crank trigger without missing tooth and multi-coils, a cam sync sensor is required. When using a single coil, the cam sync sensor is not mandatory. A several options of standard patterns are available for using with multi-coils or distributor based systems.

RPM Sensor

Select the RPM sensor used on the vehicle, VR or Hall Effect.

VR internal ref: Only use this option when told by our tech support. This is used for compatibility with older units only.

VR Differential: Select this for VR sensors; it's less susceptible to electromagnetic interference. When the crank trigger signal is split with the OEM ECU this option is mandatory.

Hall/VR with pull-up: Select when using Hall effect RPM sensor or when experiencing problems with electromagnetic interference.

RPM Signal Edge: this option changes the way the ECU reads the RPM signal. As there's no simple way of telling which one is the correct option (without an oscilloscope), select the option Standard (Falling Edge). If the ECU sees no RPM signal during initial startup, change this parameter to Inverted (Rising Edge)

First tooth alignment: set here the crank trigger alignment related to the TDC. This alignment can be checked by turning the engine to the cylinder #1 TDC and counting, counterclockwise, angle distance, from the crank trigger gap to the RPM sensor. If there crank trigger has no gap, the angle distance is from the previous teeth to the RPM sensor. For engines with distributor and Crank trigger, check our Technical Support for information about the alignment in use.

Below is a table with known alignment values and configurations for most of the cases:

Crank trigger - pattern	Engine/ brand	Recommended Index position	Cam sync sensor
60-2	BMW, Fiat, Ford (inj. Marelli), Renault, VW, GM	324° (BMW) 123° (GM) 90° (others)	Not mandatory
48-2			Not mandatory
36-1	Ford (ECU FIC)	90°	Not mandatory
36-2-2-2	Subaru	55°	Not mandatory
36-2	Toyota	102°	Not mandatory
30-1			Not mandatory
30-2			Not mandatory
24-1	Hayabusa	110°	Not mandatory
24-2	Suzuki Srad 1000		Not mandatory
24 (crank) or 48 (cam)		60°	Falling edge
12-3	Bikes Honda CB300R		Not mandatory
12+1	Honda Civic Si	210° or 330°	Not mandatory
12-1	Bikes Honda/ Suzuki/ Yamaha		Not mandatory
12-2			Not mandatory
12 (crank) or 24 (cam)	Motorcycles/ AEM EPM/ Honda distributors 92/95-96/00		Falling edge
8 (crank) or 16 (cam)			Falling edge
4+1 (crank)			Not mandatory
4 (crank) or 8 (cam)	8 cylinders	70°	Falling edge

3 (crank) or 6 (cam)	6 cylinders	60°	Falling edge
2 (crank) or 4 (cam)	4 cylinders	90°	Falling edge

Smart cranking RPM sync: option to allow faster RPM detection during cranking, specially for high compression ratio and light weight rotating setup, such as motorcycle engines.

7.3 Cam sync sensor

This option indicates if a cam sync sensor will be used and if it uses a hall effect or magnetic variable reluctance (VR) sensor. This sensor is mandatory when controlling fuel or timing in sequential mode. Without cam sync sensor the injection mode will be only semi-sequential or multipoint. Ignition will be always wasted spark.

Random cam sync sensor option is a test mode that automatically assumes a position for the cam sync signal. Use this only for testing purposes, as this may cause misfires in some applications. Use this option only for tests, because with individual coils and sequential ignition the firing order can be lagged (inverted) in 360°, so the engine won't start.

Cam sync sensor edge: this option changes the way the ECU reads the cam sync signal. As there's no simple way of telling which one is the correct option (without an oscilloscope), select the option Falling edge. If the engine starts with misfires, change this parameter to Rising edge.

Cam sync sensor for synchronization

Cam sync signal will be used only for 10 revolutions after engine start and after that will be disregarded for engine synchronization but it will still be recorded on the datalogger.

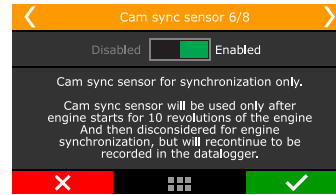

Cam sync position angle

The adjustment is degrees before top dead center (°BTDC) of cylinder 1 combustion.

This angle is not mandatory and won't affect the ignition calibration. If you don't know the position angle, set the same alignment as crank index position or select the cam sync sensor as random.

With the random panel mode enabled, the position angle in the log and diagnostic panel.

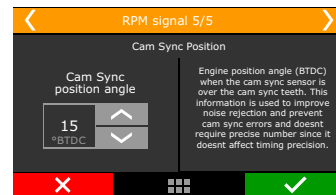

Cam sync reading mode

Select if there's a single tooth or multi-teeth used for cam sync, and in case there are multiple teeth, a tolerance between them must be set next, this value is in percentage and it's based on a table that must be set through FTManager.



Cam sync wheel decoder

This feature must be used with the ignition on, it'll automatically read all the teeth in the cam sync, then a signal edge used for cam sync can be selected.

Cam sync signal

Sensor type

- Hall / VR with pull-up
- VR differential (FT600)
- VR (FT450/500/550)
- Diagnostic - Random Hall
- Diagnostic - Random VR (FT450/500/550)
- Diagnostic - Random VR differential (FT600)
- Not used

Cam sync sensor for synchronization only

Enabled

Cam sync sensor will be used only after engine starts for 10 revolutions of the engine and then discontinued for engine synchronization, but will continue to be recorded in datalogger.
Warning: Not recommended when custom no missing tooth crank trigger and individual coils.

Cam Sync Position

Cam Sync position angle: 0.0 °BTDC

Engine position angle (BTDC) when the cam sync sensor is over the cam sync teeth. This information is used to improve noise rejection and prevent cam sync errors and doesn't require precise number since it doesn't affect timing precision.

Cam sync reading mode

Single tooth

Sensor edge

Window filter detection angle: 0

The cam sync detection window restricts the reading of signals around the angle of the cam sync position, discarding any signals outside this window. This option makes possible to use multi-teeth cam sync triggers.

Multi teeth

Tolerance between teeth: 10.0 %

Sensore edge

- Rising
- Falling
- Rising and Falling

Cam sync teeth table

Tooth	Start angle	End angle

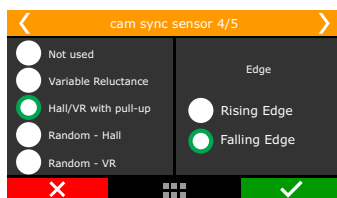

Borda n°	Ângulo do sinal	Ângulo BTDC	Padrão do sinal
<input checked="" type="checkbox"/>	1	23.1	32.20
<input type="checkbox"/>	2	35.7	7.10
<input type="checkbox"/>	3	113.2	572.00
<input type="checkbox"/>	4	185.8	426.80
<input type="checkbox"/>	5	203.0	392.40
<input type="checkbox"/>	6	275.8	246.80
<input type="checkbox"/>	7	293.1	212.30
<input type="checkbox"/>	8	305.8	186.90

Cam sync position

Cam sync position is used to create a range within which a Cam sync signal is read and all others out of it are discarded, allowing the use of a single reference on multi-toothed Cam sync pulleys.

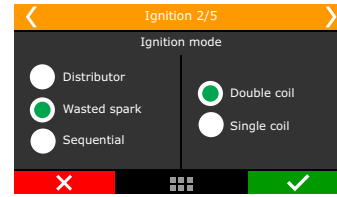
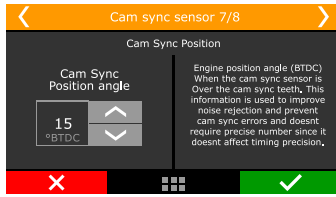

7.4 Ignition

This menu sets everything related to the ignition control mode and there is a "Default" mode (configurable through the ECU or PC) and a "Custom" mode (configurable only through the PC). When the ignition is set as "Disabled", timing maps are unavailable and only the fuel control is enabled. Gray outputs are free to be set up as injectors or auxiliary outputs.

Default: this mode makes the options available the options that are commonly used for the majority of engines, with standard firing order tables and configurations.

Custom: this mode enables all the options related to the ignition control, as customizable firing orders and angles, etc. When using this mode, ignition configuration can only be done through a PC with FTManager Software.

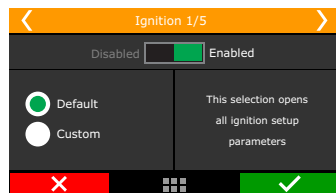
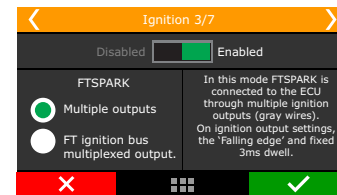
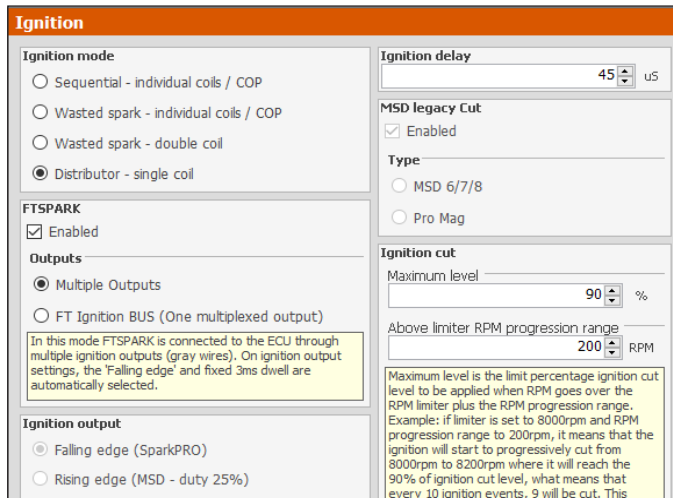

Ignition Mode

Select if the ignition will be controlled in sequential (cam sync sensor needed) or wasted spark modes or if a distributor will be used for that control. There is also the wasted spark mode, where the coils work in pairs.

The option "distributor" means that the spark distribution will actually be done by a distributor, with a single coil, regardless of the number of cylinders. Only the ignition output #1 (gray #1) will be used to control the ignition coil, the others are disabled.

FTSPARK

Select the FTSPARK check box when using the fueltech FTSPARK module and select the connection mode with it:

Multiple outputs: this is the conventional way of connecting FT to any ignition module, using an ignition output to trigger each coil (double or single). In this case one or more ignition outputs will be connected to the FTSPARK.

FTIgnition BUS (one multiplex output): Select this option to enable only one ignition output to send all the ignition trigger signals to the FTSPARK via the FT Ignition BUS. In this way the other outputs that would be used for ignition can be reallocated to other functions.

Output Test

When the multiplexed output is selected, its possible to test the FTSPARK outputs using a "test function" on the FTManager. To do so, go to 'Sensors and Calibration' then 'Outputs' and select FTSPARK - Output test.

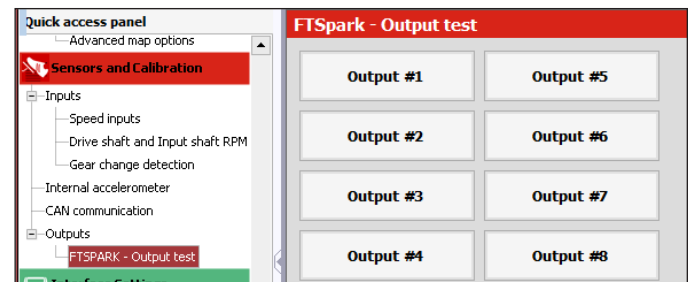

Ignition output

Select the ignition output edge/mode.

Falling edge (SparkPRO): Select this option when using FuelTech SparkPRO, M&W ignition, smart coils (integrated igniter, such as GM LS coils). This mode has dwell control enabled. It's important to know the dwell requirements or "charge time" of your particular ignition coil(s).

- **Rising edge (MSD duty 50%):** select this option when using MSD, Crane, Mallory or other capacitive discharge ignitions (CDI). This mode has a fixed 50% duty cycle signal.
- **Rising edge (Honda Distributor):** this option must only be selected when using Honda distributor with stock igniter (the one that's integrated to the distributor). This mode has dwell control enabled. Select this option only when using Honda OEM igniter and distributor.

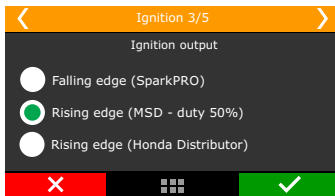

Ignition cut

The ignition cut maximum level is the percentage of ignition events that will be cut to limit the engine RPM.

The RPM progression range acts like a smoothing for the ignition cut. Example: rev limiter at 8000rpm, RPM progression range at 200rpm. From 8000rpm the ignition cut level will gradually increase until it reaches 90% cut at 8200rpm.

Percentages less than 90% may not keep the engine under the rev limiter. Bigger RPM progression range tend to stabilize more smoothly the rev limiter, but allows the RPM to pass the RPM set as rev limiter.

These numbers are valid to all kinds of ignition cut, with the exception of time based compensations (time based RPM and driveshaft RPM/wheel speed) and 2-step. These features have their own parameters. For inductive ignition systems it is recommended to use 90% maximum level and 200 RPM progression range. For capacitive system, like MSD, it is recommended to use 100% maximum level and 1 RPM progression range.

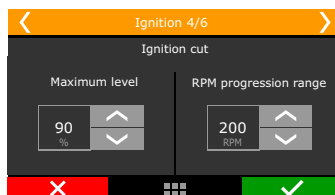

External cut

This mode is only available when using a distributor and a MSD ignition module. Enabling this option means the ignition cuts will be performed by the MSD using the Legacy input they have.

To use MSD Legacy cut a FT600 white wire has to be connected to the MSD Legacy right pin. By standard, White#10 is setup as ignition cut.

When experiencing problems with the cut through MSD like no cut at all or RPM limit always 500 RPM above what was setup, use the other MSD pin.

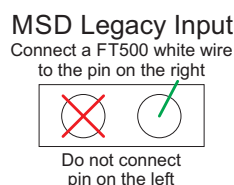
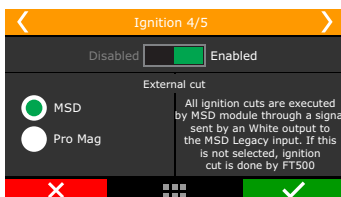

Ignition Delay time

That's the delay time the ignition module has between receiving a signal to spark and effectively spark at the plugs. Time is given in microseconds (uS).

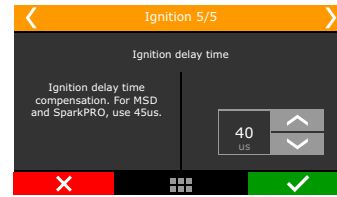

7.5 Fuel injection

In this menu, all the options related to fuel settings must be configured.

Basic: This mode makes available the options that are commonly used for the majority of engines, with standard injection angles and configurations.

Advanced: This mode enables all the options related to the fuel control, as customizable injection angles, etc. When using this mode, fuel injection configuration can only be done through a PC with FTManager Software. It is also possible to customize all the fuel tables and RPM positions, adding RPM, TPS or MAP points according to the engine needs

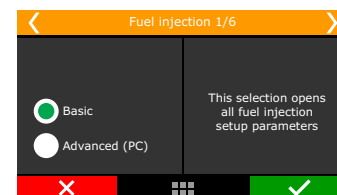
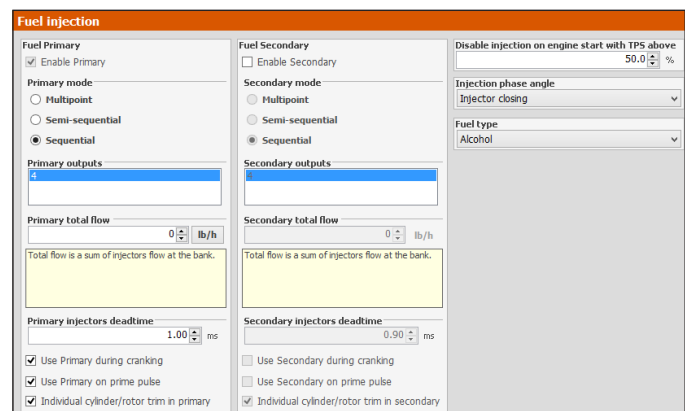

Fuel Banks: select primary and secondary (if used) banks control mode.

Multipoint: All the injector's outputs will fire at the same time, as batch fire.

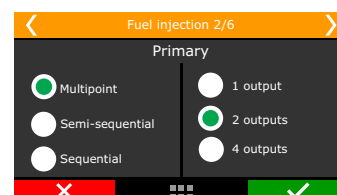

Semi-sequential: in this mode, injectors are fired once per engine revolution, at 0° and 360°, in pairs, according to the twin cylinders. In a 4 cylinder engine, cylinders 1 and 4 will be fired at the same time, then cylinders 2 and 3 at the same time.

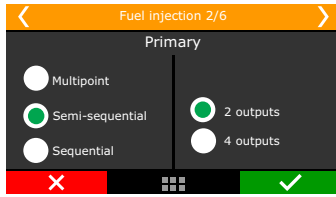

Sequential: in this mode, each injector output fires only a single time per engine cycle (720° on a 4 stroke). This mode is only available when a cam sync sensor is properly set up.

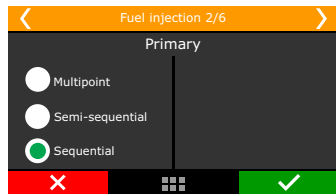

Injector's total flow

That's the total flow of all injectors on the bank (primary or secondary). This data is used to allow addition of some fuel tables in lb/hr i.e. four 80 lb/hr injectors on primary bank have a total flow of 320 lb/hr (80 x 4).

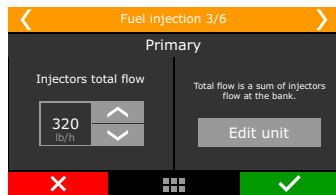

Fuel type

Select the fuel used on the motor. This information is used to create a better base map

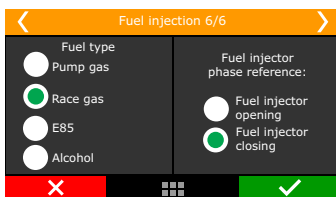

Fuel injection phase reference

Select if the Fuel injection phase angle table will be based on the injectors opening or closing. The angular distance is the measure between the ignition TDC of each cylinder and the moment the injector should open or close

Fuel injector opening: in this option it is only possible to know the angle the injector will open, but, its closure will vary according to injection time and RPM, this means that, depending on these factors, the fuel injection may still be occurring even after the intake valve has closed

Fuel injector closing (default): This is the most commonly used option as the fuel injection always occurs before the end of the intake cycle, no matter the injection time or RPM.

7.6 Pedal/Throttle

Select the option "TPS" when using a mechanical throttle, driven by cable.

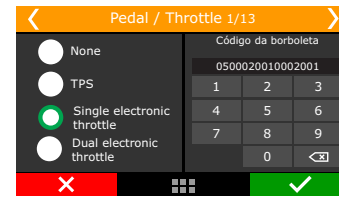
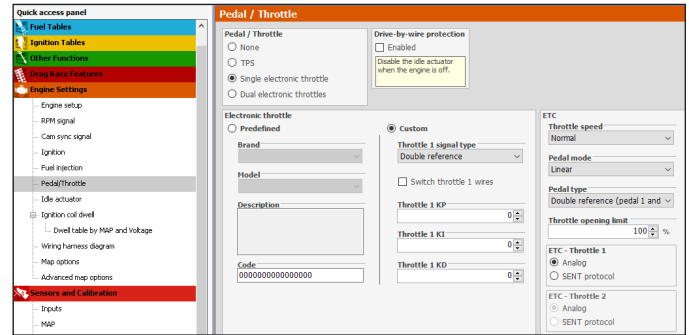

TPS

When using a throttle drives by cable with a potentiometer on the throttle shaft select the TPS option.

Standard input for TPS sensor signal is #11(FT600) and #3 (FT450 / FT550), but it is possible to set this input on any available input. Pedal/Throttle calibration must be performed as shown in chapter 12.4

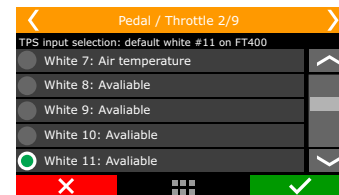

Electronic throttle control ETC

First data to be inserted on the ECU when using electronic Throttle is its code (not the throttle part number). This code is found on the FTManager Software. If your throttle is not on the list, please, contact our tech support to check compatibility first.

Throttle position sensor input

If the map is generated in the FTManager software the ETC inputs will be automatically allocated and can be checked in "Sensors and Calibration" menu, then "Inputs".

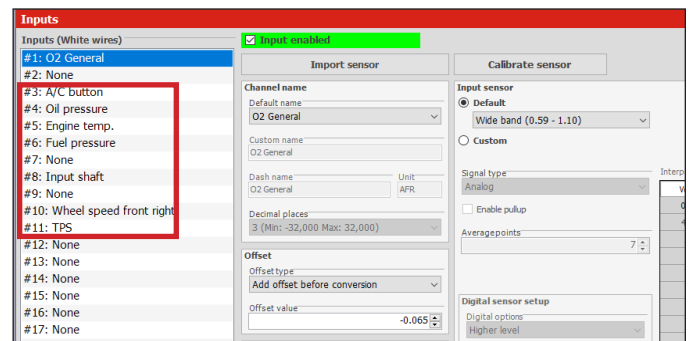

After inserting the Throttle code, set the input that will be connected to the throttle position sensor, usually there are two signals on the throttle. Standard inputs are wires white #11 (Throttle signal #1A) and white #10 (Throttle signal #1B).

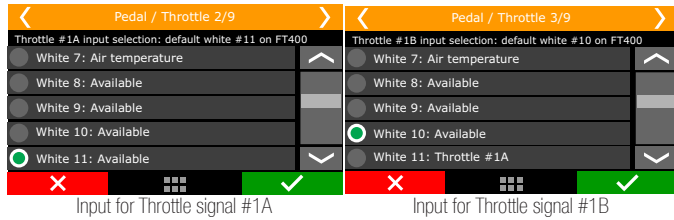

Now, setup the inputs that will be connected pedal #1 and pedal #2 position sensors. The standard inputs are wires white #9 (pedal #1) and white #8 (pedal #2).

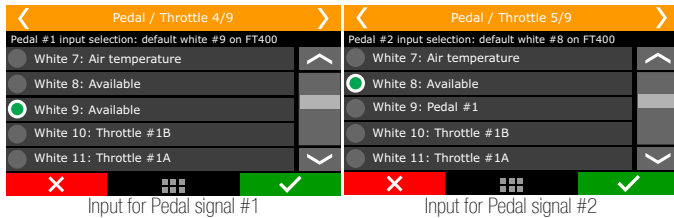

Electronic throttle control motor outputs (FT550/LITE and FT600 only)

When generating the map in the FTManager the Yellow #3 and #4 will be selected to ECT motor control.

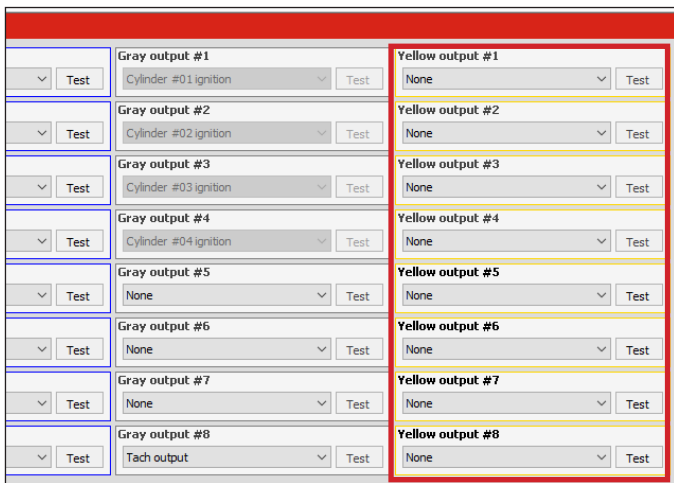

Select the outputs that will control the two wires from the throttle motor. By standard they are yellow #3 (motor 1A) and yellow #4 (motor 1B). In case these outputs are already being used by another kind of control, use outputs yellow #1 and yellow #2

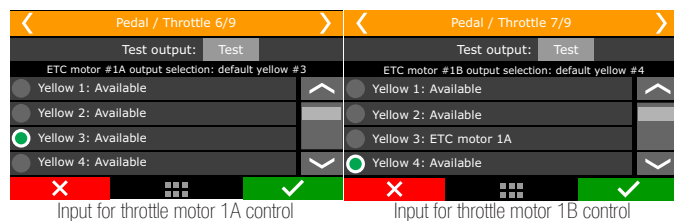

The next parameter to be setup is the Throttle speed.

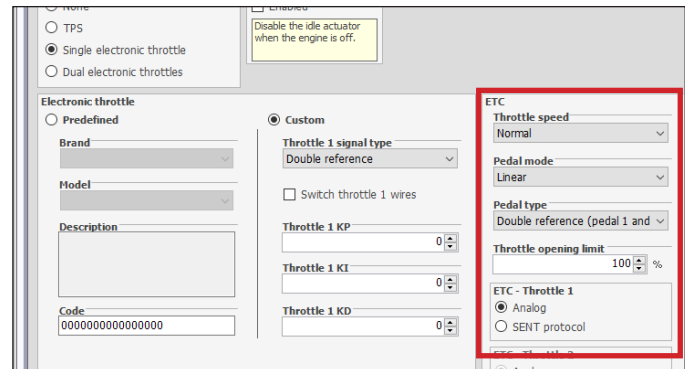

There are five control modes:

- Normal:** normal throttle response little bit faster than the stock ECU.
- Fast:** fast throttle response.
- Smooth:** smoother control mode, used on street cars and automatic transmissions.
- Smooth when cold and normal when hot:** changes the control mode according to the engine temperature, starts with smooth mode, and then changes to normal mode automatically.
- Smooth when cold and fast when hot:** changes the control mode according to the engine temperature, starts with smooth mode, and then changes to fast mode automatically
- Custom:** Option to configure throttle opening curve according to gear and engine RPM.

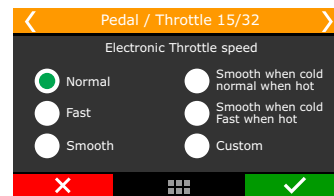

It is possible to turn off the Throttle when the ignition on, being activated only when the ECU detects RPM. This option is very useful where you want to test the system and you don't want the throttle to stay on for a long period.

- Operation mode:** this parameter changes the ratio between the pedal and the throttle.
- Linear:** this mode has a 1:1 ratio between pedal and throttle.
- Progressive:** recommended for street cars.
- Aggressive:** throttle/pedal ratio is 2:1. When pressing 50% pedal, throttle is already on 100%.
- The last parameter to be configured is an opening limiter, very useful to limit the engine power by the throttle.
- Use 100% when no safety limit is wanted.
- Custom:** enables a table where the pedal x throttle ratio can be freely customized. Very useful when using big throttle bodies, allows you to build your own throttle progression.
- Custom Pedal pos. and RPM:** Relation between throttle and RPM through a pedal x throttle x RPM percentage table, very useful for motorcycle throttles where there is a very fast opening variation.

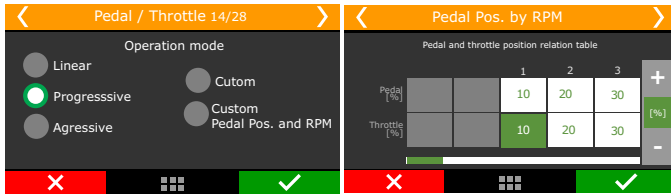

Throttle opening limit: allows you to define a limit for the opening of the throttle. This option is very useful where you want to control the maximum throttle opening, thus limiting engine power.

7.7 Idle actuators

This menu allows you to select the idle actuator used on the engine and the outputs that will control it. After this quick setup, the idle speed parameters must be done according to chapter 19.2.

An important tip is that, when selecting “No Actuator”, it is still possible to control idle speed by ignition timing as configured in the “Other Functions” then “Idle Speed” menus. If any kind of actuator is selected, the idle speed by timing control is automatically enabled. This happens because the idle speed control was specially developed for this FT, integrating the timing control with the actuator reactions

Electronic throttle

Select this option, then go to “Idle speed control settings”, under “Other Functions” menu.

Check Chapter 19.2 of this manual for more details.

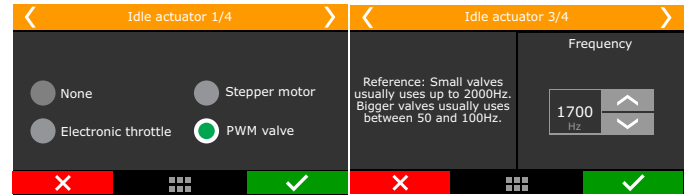

Stepper motor

In this option, the four yellow outputs are used. It is necessary to inform which output controls which step motor output and the step motor type. There are predefined actuators for VW and GM models (number of steps) and a “Custom” mode that allows the configuration of steps. As there are many variables in the manufacturing process, if you’re experiencing difficulties at idle tuning, check the “Custom” mode and change the number of steps. In some GM step motors, 190 is the correct number. For some VW step motors, 210 works better. The option “Fully open for TPS over 90%” fully opens the idle valve when TPS is above 90%, increasing the air admitted.

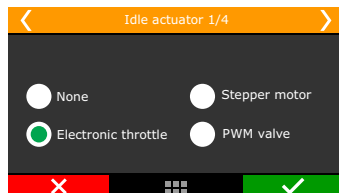
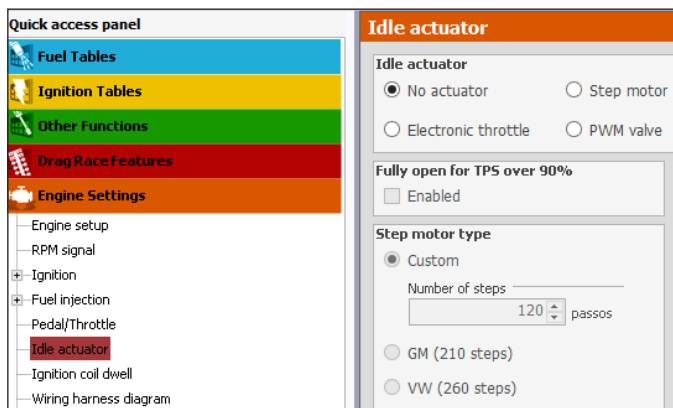
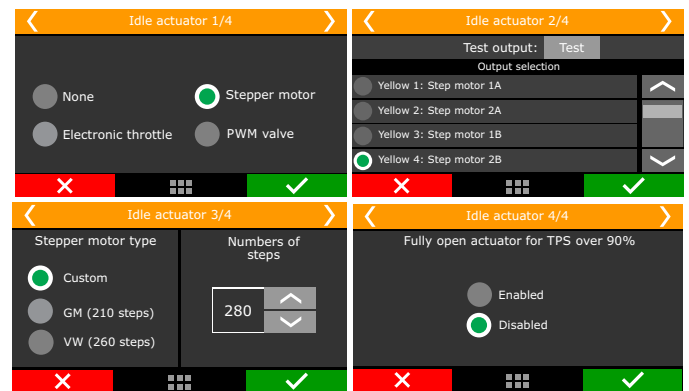

PWM Valve

After selecting this option, it will be necessary to set up the output connected to the valve and the control frequency. Small valves usually use up to 2000Hz. For big valves use around 100Hz. If your valve becomes noisy, that means the control frequency is lower than what the valve requires. In this case, increase the control frequency.

Be aware that the only outputs that can control these kinds of valves are the yellow ones.

7.8 FuelTech base map

With the “Engine Setup” menu fully set up, the next step is to generate the FuelTech base map, a function that generates fuel and ignition maps to be used as a start point for the engine tuning.

The window below is displayed at the end of configuration assistant in the FTManager:

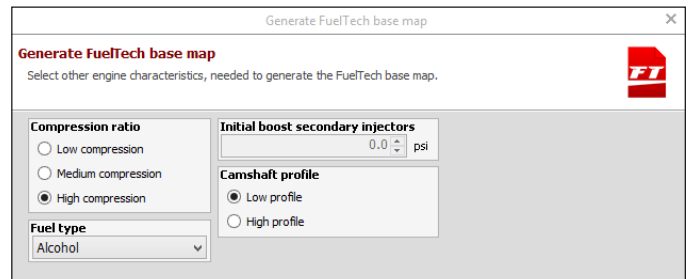

When generating a base map in the touchscreen interface, the information will be displayed similar to the images below:

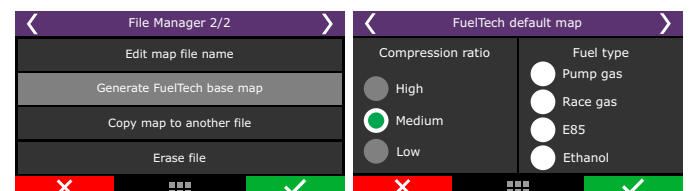

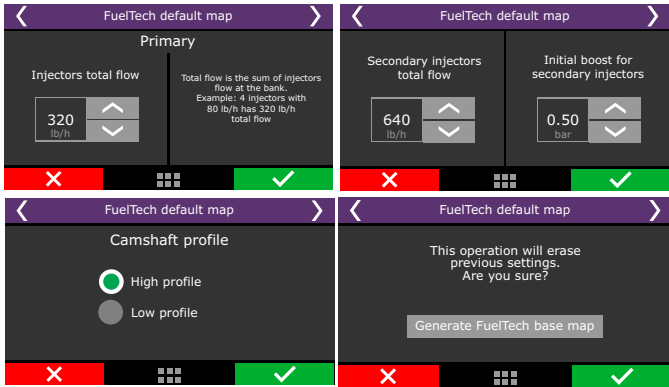

Compression ratio: used to correctly estimate the timing tables. A low, medium or high compression ratio is defined according to the fuel used on the engine and if it is turbocharged or naturally aspirated. I.e., a 10:1 compression ratio for a naturally aspirated engine using ethanol is considered a "low compression ratio". The same ratio for a turbocharged engine running gasoline will be "high".

Primary and secondary injector's total flow: select the flow of the injectors responsible for the naturally aspirated/low load range of the engine.

Initial boost for secondary injectors: Here is where you will set the pressure you want the secondary bank to start opening, usually under boost. This option is only shown when using two banks of injectors

Camshaft: select the characteristic of the engine camshaft. When selecting high profile camshaft, all injection tables from absolute vacuum until -4.3psi are equal, as this type of camshaft does not have steady vacuum at idle speed. When selecting low profile camshaft, the injection times at vacuum phase are filled up in a linear manner.

Now, click the button "Generate FuelTech base map". The ECU will show a warning that the current map will be overwritten by the FuelTech base map.

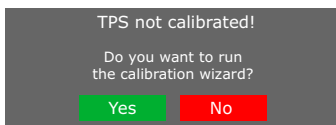

A notice about throttle/pedal calibration will be displayed. Click Yes and you will be redirected to the calibration screen.

The Chapter 15.1 has detailed information about the calibration. The next chapters explain other functions contained in the Engine Settings menu.

7.9 Fuel injectors deadtime

All fuel injectors, as they are electromechanical valves, have an opening inertia, which means that there is a "dead time", a moment in which the injector has already received an opening signal, but still has not started to inject fuel. This parameter considers, as a standard value, 1.00ms for high impedance fuel injectors. For low impedance injectors using Peak and Hold driver, set the deadtime to 0.60ms. These are

general values; check this parameter with the injector manufacturer. In the FTManager, this parameter is in the Injection menu in "Engine Settings".

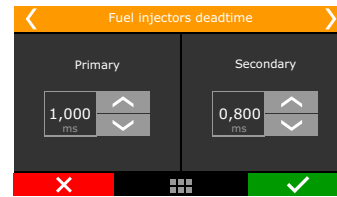

7.10 Ignition Dwell

This option sets the ignition coil charging time. There is a dwell table because the charging time varies according to the battery voltage, especially in vehicles that do not have alternator.

Usually, the lower the voltage, the higher the dwell time has to be set.

Smart coils (coils with internal igniter) demand lower charging times. These are general values; check this parameter with the coil manufacturer.



WARNING
 When using MSD ignition modules, it's not possible to control the Dwell time. In this case, the coils charging time is calculated by th MSD module.

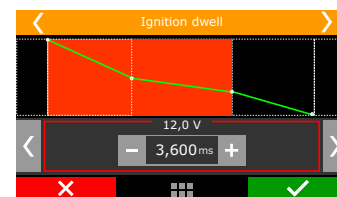

7.11 Ignition energy

This menu allows the user to program the ignition energy of the FuelTech FTSPARK ignition module.

This 3D table relates engine RPM, MAP (boost/vacuum) and the desired mJ (millijoules) value.

The ignition energy control is done by connecting both equipments (FT ECU and FTSPARK) by their CAN network.



7.12 Map options

Select the ECU model that is connected to the PC and which features will remain visible on the active map.

This makes navigation through the software much easier by hiding unused menus.

In case you need to make an option visible again, just go to Engine Settings and then Map Options.

Vehicle mode

There are three modes, combustion, electric and hybrid

Combustion: Enable this function for conventional combustion engine control, powered by Ethanol, Methanol, Gasoline and derivatives.

Electric: Enable this function to use only the electric motor control, all other functions for combustion engines will be hidden to facilitate the use of the equipment.

Hybrid: Enables all functions for electric and combustion control.

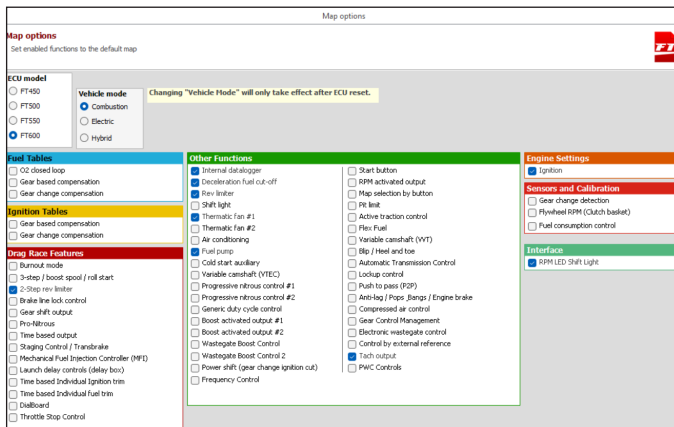

7.13 Advanced map options

There are some options that are only available through FTManager. To access them, go to "Engine Settings" Menu:

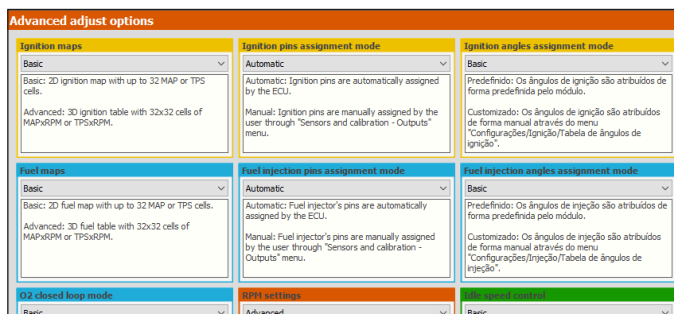

Injection

Fuel maps

- Basic - fuel maps are in a 2D table that relates MAP x injection time or TPS x injection time.
- Advanced - 3D MAP x RPM or TPS x RPM fuel table with 32x32 cells.

Fuel injection pins assignment mode

- Automatic - fuel injector's pins are automatically assigned by the ECU.
- Manual - fuel injector's pins are manually assigned by the user through "Sensors and Calibration - Outputs" menu.

O2 closed loop mode

- Basic - Predefined options for the O2 closed loop.
- Advanced - Enables advanced options for the O2 closed loop.

Ignition

Ignition maps

- Basic - ignition maps are in a 2D table that relates MAP x timing or TPS x timing.
- Advanced - 3D MAP x RPM or TPS x RPM timing table with 32x32 cells.

Ignition pins assignment mode

- Automatic - ignition pins are automatically assigned by the ECU.
- Manual - ignition pins are manually assigned by the user through "Sensors and Calibration - Outputs" menu.

RPM settings

- Basic - Pre-defined voltage detection levels for VR crank and cam sensors.
- Advanced - The adjustment of voltage levels for detection of VR sensors in advanced mode allows the conditioning of non standard crank/cam signals, especially when they're spliced with the stock ECU.

Other Function

Internal Datalogger

- Basic - fixed sampling rates.
- Advanced - configured sampling rates per channel.

Idle speed control

- Basic - predefined options for controlling idle. Meet 99% of the vehicles.
- Advanced - releases advanced options such as PID control, target approach RPM, deadband, approach RPM, etc.

Wastegate boost pressure control

- Basic - predefined options for the wastegate boost pressure control.
- Advanced - enables advanced options for the wastegate boost pressure control.

8. Electrical installation

As FT wires are fully configurable according to the installation needs, it is very important that the step by step guide shown on chapter 5 is followed before starting the electrical installation. This way the wiring harness connection table is automatically filled as shows the example below:

In the FTManager, to check all the inputs and outputs, go to “Sensors and Calibration” menu, then “Inputs” or “Wiring harness diagram”.

Outputs			
Blue output #1 Fuel injection cyl. #01 - Primary	Blue output #9 None	Gray output #1 Cylinder #01 ignition	Yellow output #1 None
Blue output #2 Fuel injection cyl. #02 - Primary	Blue output #10 None	Gray output #2 Cylinder #02 ignition	Yellow output #2 None
Blue output #3 Fuel injection cyl. #03 - Primary	Blue output #11 None	Gray output #3 Cylinder #03 ignition	Yellow output #3 None
Blue output #4 Fuel injection cyl. #04 - Primary	Blue output #12 None	Gray output #4 Cylinder #04 ignition	Yellow output #4 None
Blue output #5 None	Blue output #13 None	Gray output #5 None	Yellow output #5 None
Blue output #6 None	Blue output #14 None	Gray output #6 None	Yellow output #6 None
Blue output #7 Thematic fan #1	Blue output #15 None	Gray output #7 None	Yellow output #7 None
Blue output #8 Fuel pump	Blue output #16 None	Gray output #8 Flash output	Yellow output #8 None

Through the touchscreen interface, you can access this function in the “Engine Settings”, then “Wiring harness diagram”.

Wiring harness diagram		Wiring harness diagram	
White 1: O2 sensor #1		White 11: TPS	
White 2: 2-step		Blue 1: Primary fuel inj. - cylinder 1	
White 3: Air conditioning		Blue 2: Primary fuel inj. - cylinder 2	
White 4: Oil pressure		Blue 3: Primary fuel inj. - cylinder 3	
White 5: Engine temperature		Blue 4: Primary fuel inj. - cylinder 4	
Blue 8: Shift Alert		Grey 8: Tachometer output	
Grey 1: Ignition - cylinder 1		Yellow 1: PWM valve	
Grey 2: Ignition - cylinder 2		Yellow 2: Fuel pump	
Grey 3: Ignition - cylinder 3		Yellow 3: Electric fan #1	
Grey 4: Ignition - cylinder 4		Yellow 4: Available	

Based on this information, you can start the electrical installation that must be done with the ECU disconnected from the harness and the battery disconnected from the vehicle. It is very important that the cable length as short as possible and that unused parts of wires are cut off.

Choose an appropriate location to affix the module inside the car, and avoid passing the cable wires close to the ignition wires and cables, ignition coils and other sources of electric noise.

DON'T EVER, under any circumstance, install the ECU near ignition modules in order to avoid the risk of interferences.

Electric cables must be protected from contact with sharp edges on the vehicle's body that might damage the wires and cause short circuit. Be particularly attentive to wires passing through holes, and use rubber grommets/protectors or any other kind of protective material to prevent any damage to the wires. At the engine compartment, pass the wires through places where they will not be subject to excessive heat and will not obstruct any mobile parts in the engine.

Red wire - 12V input

The 12V input to FuelTech ECU, this wire must be connected to 12V from a relay (Main Relay) and cannot be shared with the positive wire that powers coils, fuel injectors or other actuators.

• **12V for sensors:** use a 24 AWG wire from the same 12V wire that feeds the ECU (Main Relay). Example: Hall Effect sensors, pressure sensors, speed/RPM sensors, etc. This wire cannot be shared with the positive wire that powers coils, fuel injectors or other actuators.

• **12V for fuel injectors:** use a 14 AWG wire connected to a 40A relay. Protection fuse must be chosen according to the peak current of the fuel injectors plus a 40% safety coefficient.

Example: for up to 4 injectors that draw 1A of current per injector on primary bank, and 4 injectors that draw 4A of current per injector on secondary bank: $(4 \times 1A) + (4 \times 4A) = 20A + 40\% = 28A$. Use a 30A fuse.

• **12V for coils, fuel pump and other high power actuators:** use a wire with at least 14 AWG connected to a relay and a fuse correctly dimensioned according to the actuator current draw. When using individual coils (COP), it is recommended a 70A or 80A relay.

NEVER share the 12V that feeds injectors, coils or other accessories, because, after shutting the engine off, there is a risk of reverse current that may damage a sensor or the ECU.

Black wire - Battery's negative

This wire is responsible for signal ground to the ECU so, it must be connected **straight to the battery's negative terminal**, with no seams. **Under no circumstances, should this wire be connected to the vehicle chassis** or split with the ECU black/white wire (power ground). This will cause electromagnetic interference and other problems hard to diagnose and solve.

The black wire must have permanent contact with the battery's negative terminal, never being connected to switches, car alarms or others. To turn a FuelTech ECU off, the red wire should be switched on and off.

- Attach the negative wires to the battery terminal use ring terminals and avoid soldering them. A well crimped terminal has better resistance than a soldered one. Besides that, solder makes the joint stiffer, and less resistant to vibration, typically found in automotive applications.
- Use a crimping tool and insulate the wire with insulating tape or heat shrink tubing.
- If there's a need to solder the wire to the terminal, check it's resistance after the solder, it should be lower than 0.2 Ohms.

NOTE: If corrosion is found (green/White powder) on the battery terminals, clean it with a wire brush and baking soda or contact cleaner spray. Double check the terminal holder and replace it if necessary. Check resistance after the cleaning, it should be lower than 0.2 Ohms.

Green/Black wire - Negative for sensors

(TPS, air temp., Pressure, rpm, distributor, etc.): It is vital to use sensors ground straight to the battery's negative terminal. Connecting them to chassis may cause electromagnetic interference, wrong readings or even damage to the sensors.



NOTE

For FT450, connect the sensor grounds to the battery negative terminal.

Black/White wire – power ground

These are the ECU power ground wires. They **MUST** be wired to the battery's negative terminal. The **power ground (black/white wire) can not** be joined to the **signal ground (black wire)** before reaching the battery's negative terminal.

The three power grounds must have permanent contact with the engine block/head, never being connected to switches, car alarms or others. To turn a FuelTech ECU off, the red wire should be switched on and off.

Power ground to ignition modules (SparkPRO, etc.), Peak and Hold drivers, relays and other accessories, must be connected to the same point, at the engine block/head.

A good test to check if the power grounds are with good connection is, using a tester, to measure the resistance between the battery's negative terminal and the chassis ground. Connect the red probe on the chassis point that the shield is connected and the black probe on the battery's negative. With the tester on the 200ohms range, the resistance measured must be below 0.2 Ohms.

Remember to touch both probes to check its resistance. This reading must be subtracted from the first reading to found the correct value.

OBS: it is very important to check the shield that connects the engine block to the chassis and to the battery. If this shield is defective, replace it by a new one, as it may cause serious damage to the ECU and its sensors. For this reason, we recommend the use of two these shields two of these shields.

Main switch installation (optional) – important tips

Main switches have been used for a long time in competition vehicles for safety purposes in case of an accident. Just like any other electric accessory, there's a correct way to install it:

The main switch cannot be connected to ground or power ground, under any circumstances!! This is the most common error by installers and, usually costs hours of work to fix all the problems that it cause. All of this without counting the huge possibility of damaging all the electronic accessories on the vehicle.

The main switch must ALWAYS control the battery's positive (12V).

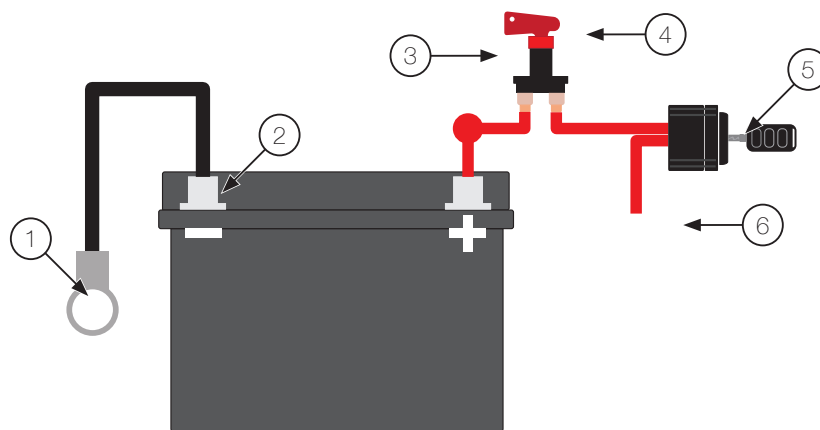

- 1 - Shield connecting battery negative to chassis and engine
- 2 - The ECU's black and black/white wires must go straight to the battery's negative terminal without being joined together along the way

- 3 - Positive wire to alternator
- 4 - Main switch
- 5 - Ignition Switch
- 6 - Switched 12V

9. Wiring PowerFT ECUs to harnesses from previous ECUs

The ECUs can be installed on vehicles which already use FT250, FT300, FT350, FT400 and FT500/FT500LITE, with no need to rewire everything. However, a few points must be checked or modified.

The best option is to make a new installation, using the FT harness, according to the recommendations here brought.

However, if to rewire is not possible, there is another alternative: to cut the old FT connectors and wiring them as shown below.

In order to do so a FT450, FT550/LITE or FT600 connector kit is needed (sold separately).



NOTE

In order to avoid any kind of damage to your installation, cut one wire at a time, crimp it and install it in the proper position.



IMPORTANT

The wire positions are sequentially numbered in back rear of both connectors. The following diagrams show the connectors from a back view, where the pins must be inserted.



WARNING

Check carefully and identify each connector:
A-Connector: 3 reference notches
B-Connector: 4 reference notches.

9.1 Connector diagram - Harness FT250, FT300, FT350 to FT450

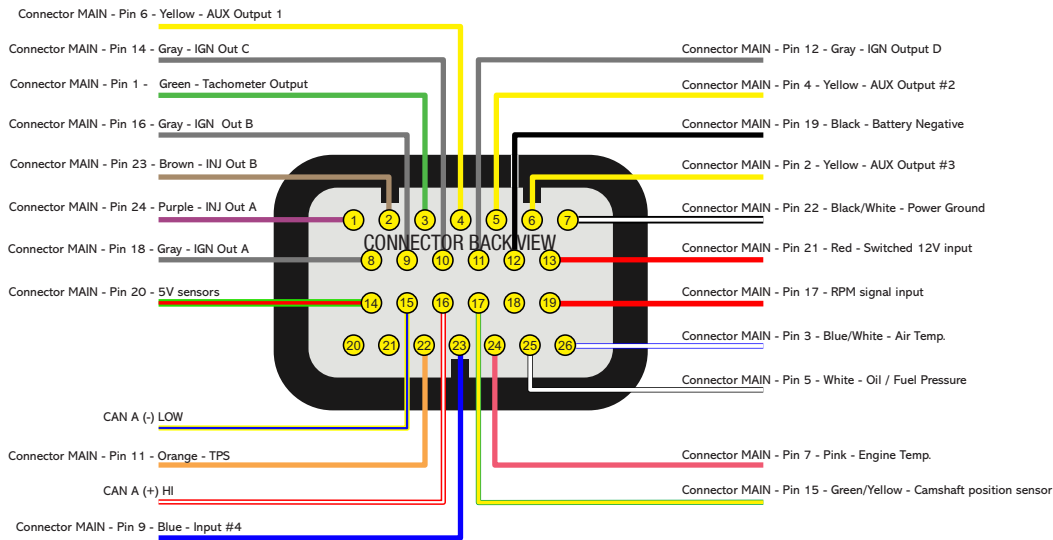

Colors of the wires in the FT250, FT300 and FT350 main harness after crimped and inserted in the FT450/FT550 A connector



NOTES

- If a 5th ignition output is needed, use gray wire E of the old harness in the
- For the FT450, use blue output number 5 for PWM idle actuators
- The Tach output feature must used on either blue 3, 6 or gray 4

9.2 Connector diagram - Harness FT400 to FT550/LITE

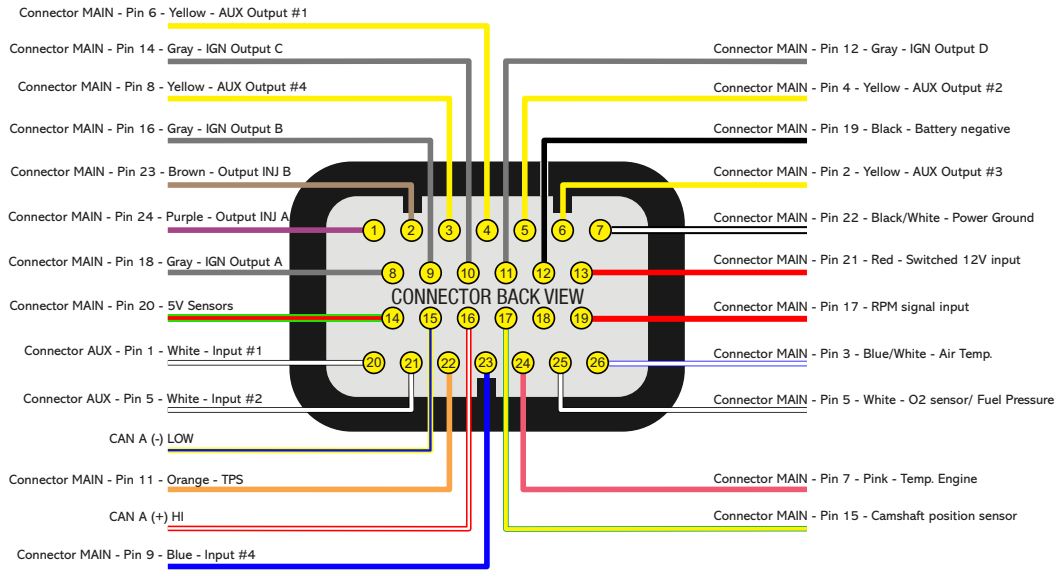

Colors of the wires in the FT400 main and auxiliary harness after crimped and inserted in the FT450/FT550 A connector

9.3 Connector Diagram - Harness FT400 to FT550/LITE

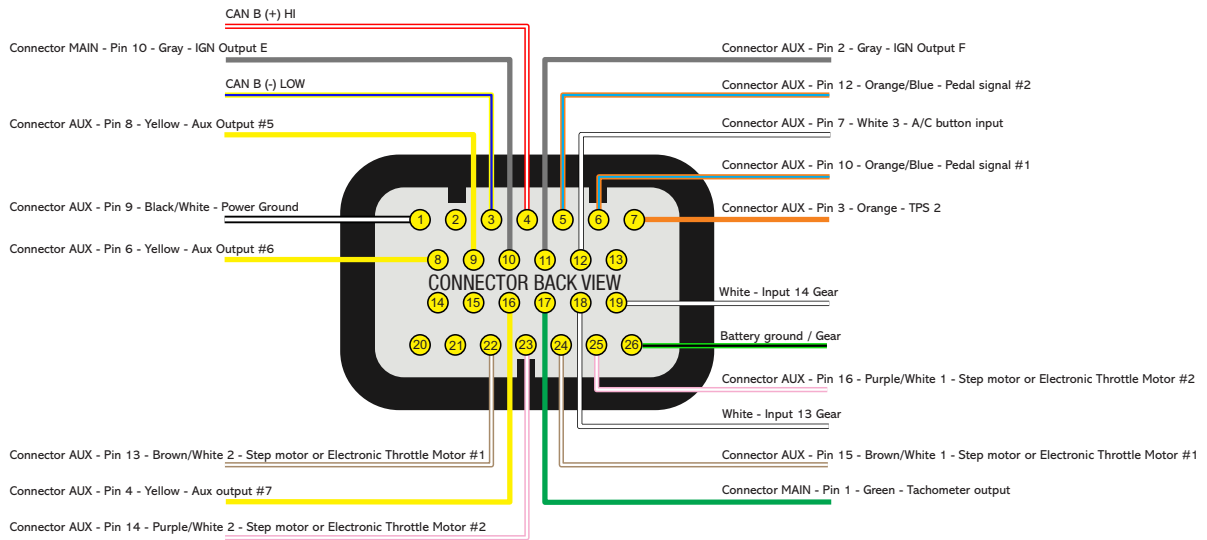

Colors of the wires in the FT400 main and auxiliary harness after crimped and inserted in the FT450/FT550 B connector



NOTE

- In order to use electronic throttle body, it is necessary to cut pins 13 and 14 from the FT400 harness

9.4 A - Connector Diagram - Harness FT500 to FT550/LITE

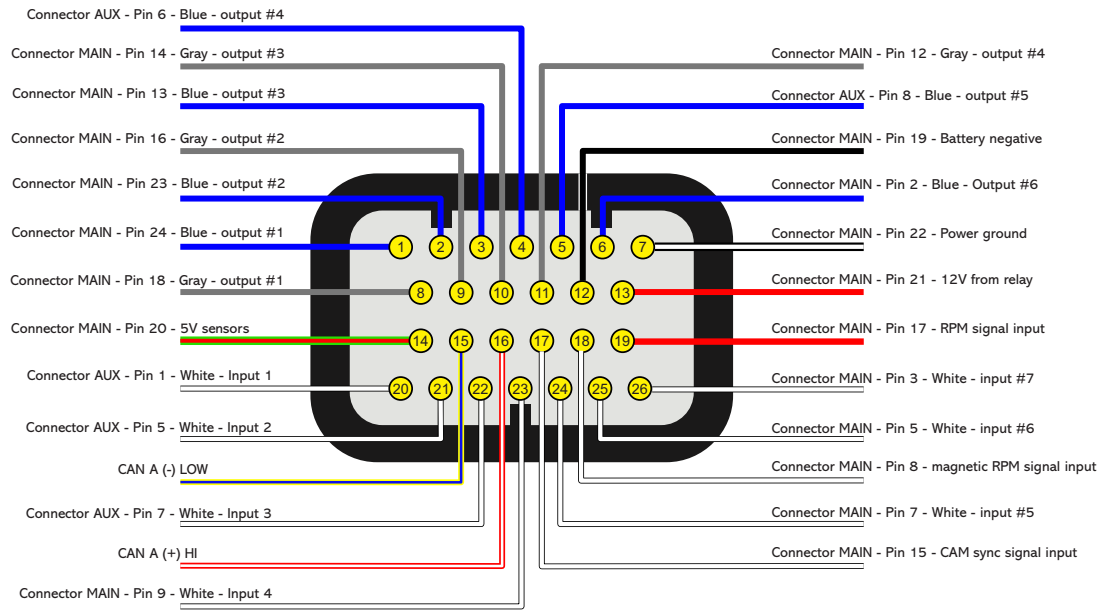

Colors of the wires in the FT500 harness after crimped and inserted in the FT550 A connector

9.5 B - Connector Diagram - Harness FT500 to FT550/LITE

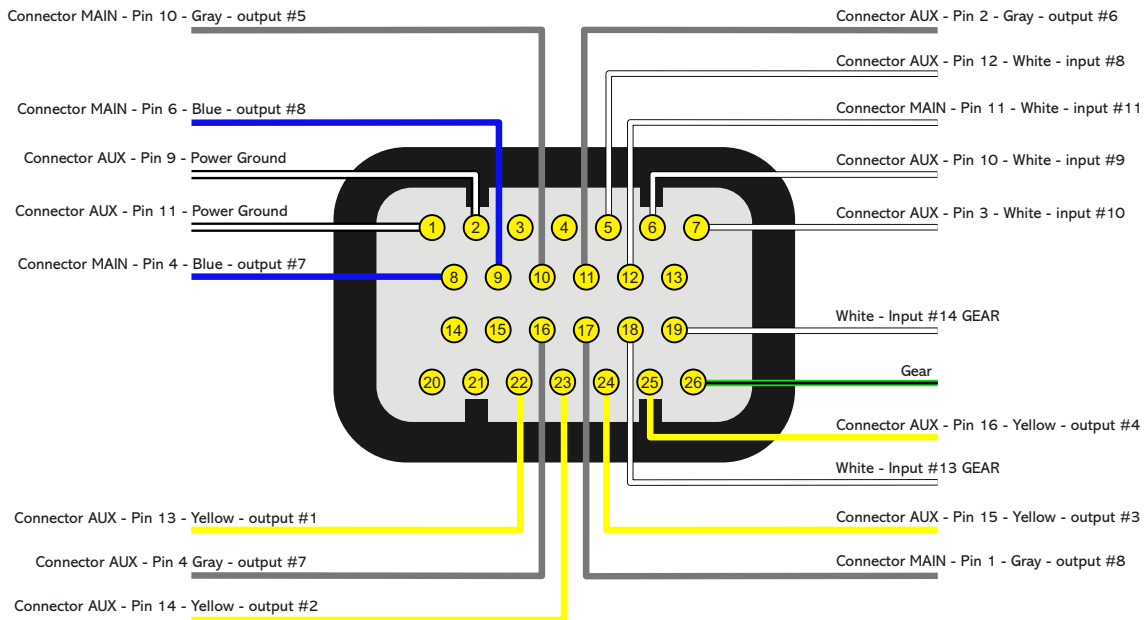

Colors of the wires in the FT500 harness after crimped and inserted in the FT550 B connector

9.6 A - Connector diagram - Harness FT500 to FT600

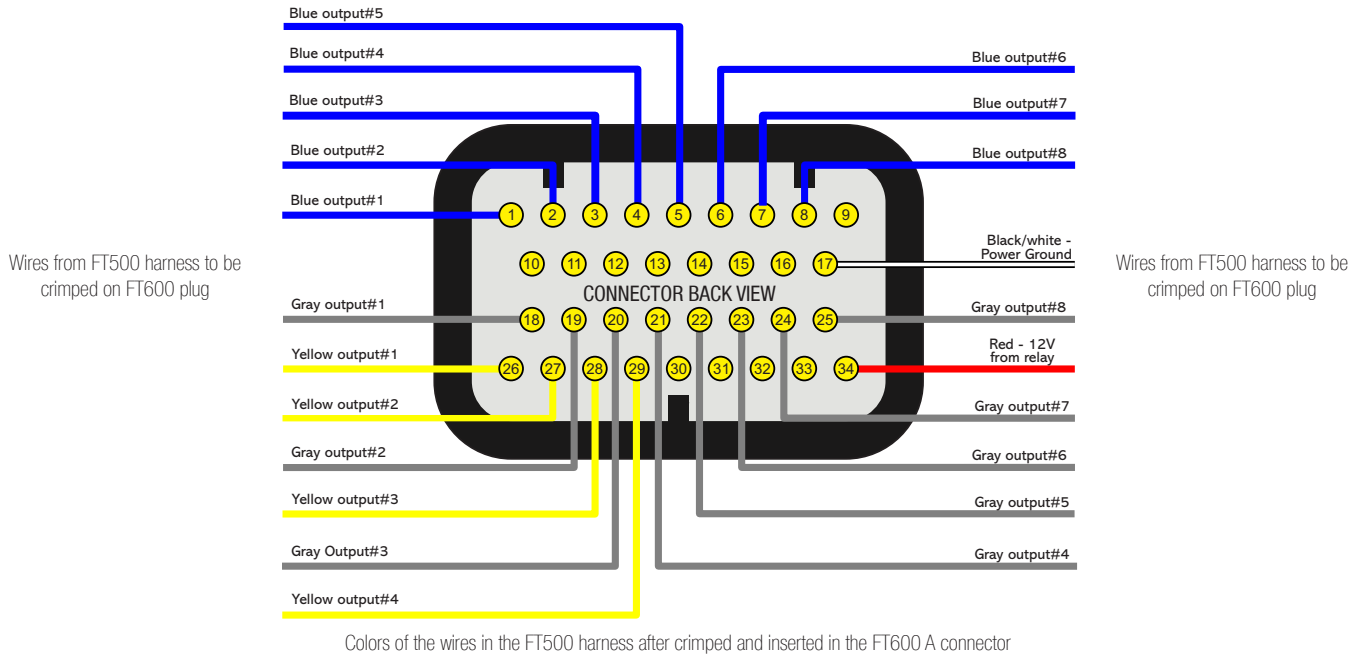

9.7 B - Connector diagram - Harness FT500 to FT600

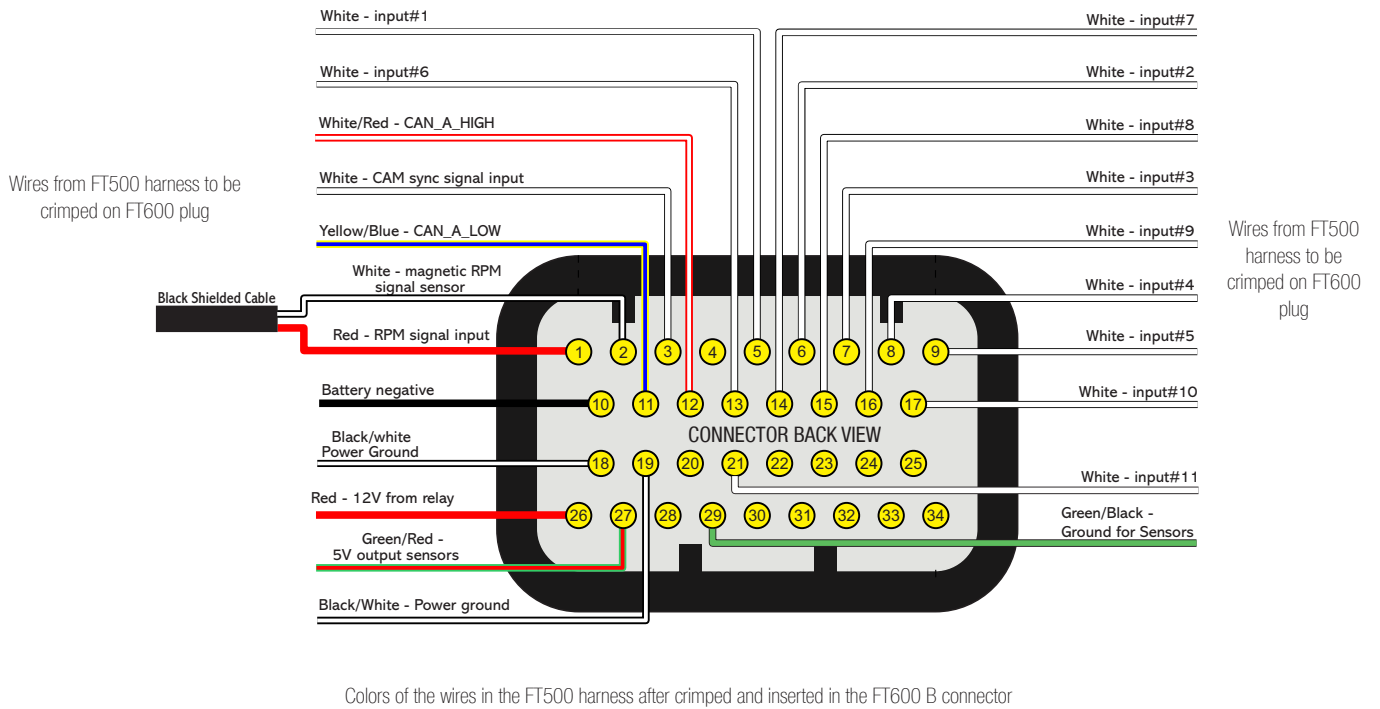

10. Fuel injectors

The FT outputs to control fuel injectors (blue wires). Each one of them can control up to 6 injectors with internal resistance above 10 Ohms (saturated injectors) or up to 4 injectors with internal resistance above 7 Ohms. Using a Peak and Hold driver, this capacity varies according to the output and the Peak and Hold current control (2A/0,5A, 4A/1A or 8A/2A).

In situations where more than 16 outputs are needed, the gray or yellow outputs can be set as injector outputs. In this case, the use of a Peak and Hold driver for these outputs is mandatory.

Injectors can be triggered in multipoint, semi sequential or sequential modes.

Examples of 4-cyl engines running high impedance injectors

- Individual triggering:** each blue output controls a cylinder. This is the most recommended connection cause is the only one that allows individual per cylinder fuel compensations, amongst other functions.

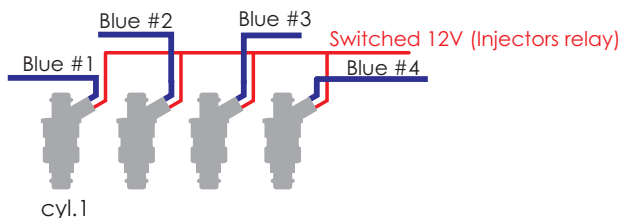

- Two injectors per channel: blue output #1** controls injector of cylinders 1 and 4. Blue output #2 controls injectors of cylinders 2 and 3

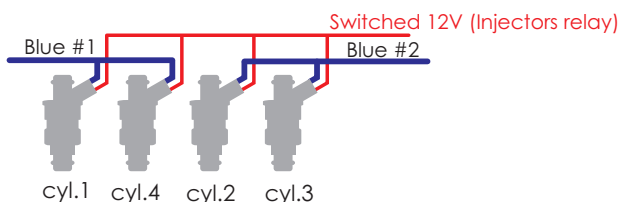

- Four injectors per channel:** use this connection only for compatibility with previous generation FT ECUs.

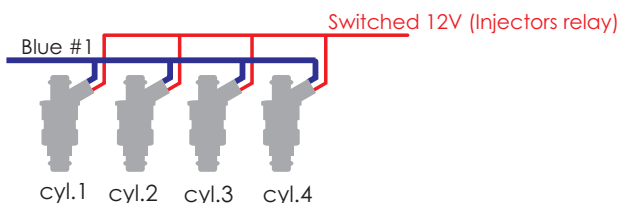

Even with each output controlling only one injector it is possible to change the triggering mode to multipoint (batch fire), semi sequential (outputs triggered in pairs) or sequential.

11. Ignition

The ECU has ignition outputs that can be used according to the needs of the project, controlling a distributor or a crank trigger.

Ignition with distributor

When using this ECU with a distributor, the only active ignition output is gray #1. This wire must trigger an ignition module or a coil with integrated igniter. When MSD configured it's utilized Yellow#1.

Coil with integrated igniter (smart coil)

They are coils with at least 3 pins and only one spark plug wire output. This kind of coil (inductive) must be set as "Falling dwell" in the "Ignition output" menu. In case of selecting the wrong output type, coil will be damaged.

FuelTech SparkPRO-1 with coil without integrated igniter (dumb coil)

The FuelTech Spark PRO-1 module is an high energy inductive igniter which has an excellent cost/benefit and can be used with any 2-wire dumb coil (without internal igniter). Coils with primary least possible resistance are recommended for maximum SparkPRO-1 potential. The minimum resistance of the coil primary should be 0.3 ohms, below this the SparkPRO will be damaged.

Try to place SparkPRO-1 as close as possible to the coil.



Warning about the SparkPRO-1:

An excessive charging time (Dwell) can damage the SparkPRO and the coil. It is recommended to use a Dwell map with 6ms at 8V, 4ms at 10V, 3.60ms at 12V and 3.00ms at 15V and check coils temperature at the beginning.



IMPORTANT

In the "Ignition" menu, select the ignition output as "Falling dwell". In case of selecting the wrong output type, coil will be damaged.

Capacitive discharge ignition module (MSD 6A, MSD 7AL, Crane, Mallory)

FuelTech's ignition output must be connected to the MSD ignition module, (usually, the white wire is the points input). When using a MSD ignition box, the yellow #1 is automatically set up as ignition output.

The installation of ignition modules must always follow what is indicated by its manufacturer in the instructions manual. This ignition module will receive a Points signal from FuelTech. Ignition coil must follow the ignition module manufacturer recommendations as well.

Important Notes:

- The module must be placed as close as possible to the ignition coil, and never inside the car, in order to avoid the risk of interference with electronic devices.
- The length of the wires that connects the ignition module to the ignition coil must be as short as possible.
- In "Ignition Setup," select the output "Rise (CDI)".
- It is not possible to control the ignition Dwell when using this type of module.
- To use the ignition cut through MSD, check Chapter 7.3

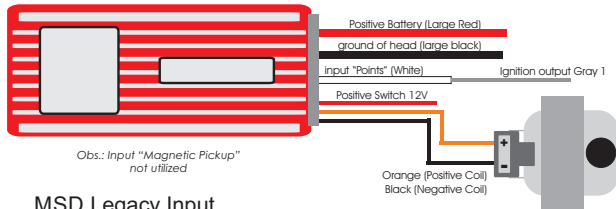

Obs.: Input "Magnetic Pickup" not utilized

MSD Legacy Input

Connect a FT500 white wire to the pin on the right

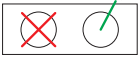

Do not connect pin on the left

- When using MSD ignition modules with a distributor, it is necessary to connect a FuelTech white wire to the MSD Legacy input. Doing so improves the response of timing control, which is especially necessary when using Drag Race Features.

- When experiencing problems with the cut through MSD like no cut at all or RPM limit always 500 RPM above what was setup, use the other MSD pin.

Ignition with crank trigger

When controlling the ignition in distributor less systems, wasted spark or individual coils per cylinder are needed. In this case, coils are triggered by different outputs, according to the number of cylinders. Ignition outputs (gray wires) are triggered according to the firing order set up on the ECU

Example: 4 cylinder engine with individual coils:

Gray outputs are selected automatically, according to the number of cylinders.

Gray wires that will not be used for ignition control can be set up as injectors outputs (Peak and Hold driver is mandatory) or auxiliary outputs (relay needed).

Individual coils – electrical connections

These connections must be done by matching the output number with the cylinder number:

- Ignition output #1 controls cylinder #1 coil;
- Ignition output #2 controls cylinder #2 coil;
- Ignition output #3 controls cylinder #3 coil.

When working with dumb coils, an external ignition module must be used (as the FuelTech SparkPRO). In this case, ignition outputs from FT600 are connected to the ignition module inputs.

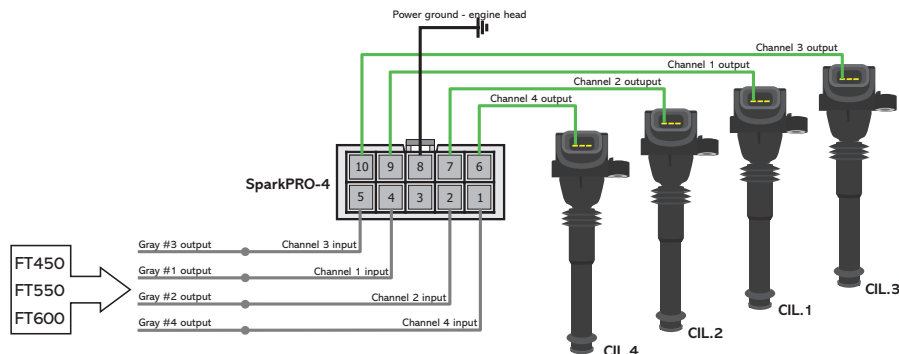
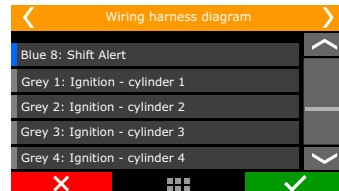

Wasted spark coils – electrical connections

In this case, ignition output #1 controls cylinder #1 and its twin, ignition output #2 controls cylinder #2 and its twin, etc.

When using dumb coils, an external igniter must be used, such as FuelTech SparkPRO. The FT ignition outputs (gray wires) will be connected to the igniter inputs and the igniter outputs will be connected to the coil.

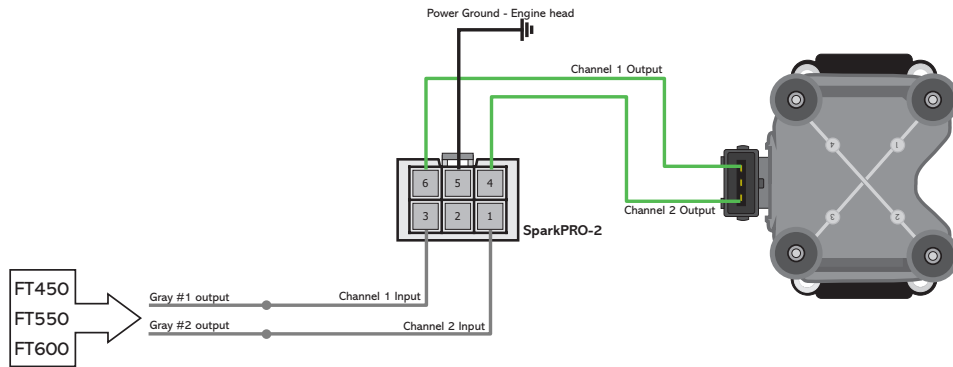

Resistor Installation gray outputs

When coils with integrated ignition module are used in your vehicle with FuelTech it's recommended to install a 100 ohms resistor (100R) in series with each gray output used in installation.

This procedure is used as a protection to the ECU against current discharges in adverse situations.



NOTE
After installing the resistor, you must insulate the area with electrical tape or heat shrink.

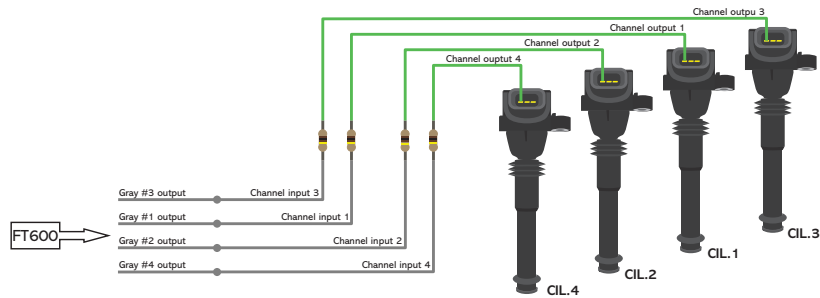

12. Sensors and actuators

The ECUs has some pre-defined sensors available as standard, but, it's possible to setup any kind of analog sensor on its inputs or even to connect it and read a sensor in parallel with the OEM ECU. This configuration is done on the custom mode through software FTManager and USB cable on a PC.

12.1 Intake air temperature sensor

With this sensor, the ECU can monitor the intake air temperature and perform real time compensations.

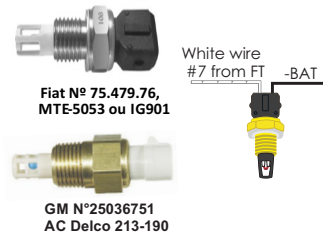

Models:

- Fiat: Delphi / NTK (3,3k Ω a 20°C);
- GM (American): ACDelco: 213-190 / GM n°25036751.

One of its pins is connected to the battery negative. The other to the white #7 wire (standard – can be changed).

12.2 Engine temperature sensor

This sensor is very important for a good running engine, as varying engine temperatures dramatically affect an engine's fuel and timing requirements.

On water cooled engines, place this sensor near the engine head, reading the water temperature. On air cooled engines, install this sensor reading the engine oil temperature.

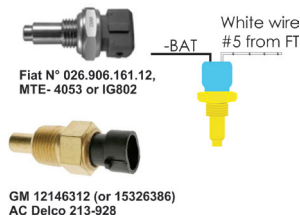

Models:

- Fiat: Delphi / NTK (3,3k Ω a 20°C);
- GM (American): ACDelco: 213-928 / GM: 12146312 (or 15326386).

One of its pins is connected to the battery negative. The other to the white #5 wire (standard – can be changed).

12.3 Fuel and oil pressure

FuelTech PS-150/300/1500 is a high precision sensor responsible for general pressure readings (fuel, oil, boost, exhaust back pressure, etc.) It can be purchased Online at www.fueltech.net or from an authorized FuelTech dealer (check the website to locate the dealer nearest to you).

FuelTech PS-150/300/1500 sensor below:

- Connection: 1/8" - 27NPT
- Pressure Range: 0 to 150/300/1500psi
- Power Voltage: 5V
- Output Scale: 0.5-4.5V
- Electric Connector: 3-way Metri Pack 150

Pin A: Battery's Negative

Pin B: 5V supply

Pin C: Output signal

FuelTech part numbers:

5005100020 - 0-150 psi sensor

5005100021 - 0-300 psi sensor

5005100022 - 0-1500 psi sensor



As FT600 is fully configurable, practically any automotive pressure sensor can be used – if the voltage x pressure table is known, you can setup through FTManager software.

12.4 Throttle position sensor (TPS)

This sensor is a potentiometer installed on the throttle to inform the ECU about its position. If needed, it is possible to run the engine without this sensor, but, it is very important for a fine tuning. When possible, use the OEM TPS. This ECU is calibrate to any kind 0-5V TPS sensor. Anyway, FuelTech products are compatible with any 0-5V TPS sensor, since they have calibration function.

Finding connections for TPS sensors

Using a multimeter, select the 20k Ohms range, unplug the ECU harness and leave the ignition off. Put the test probes on 2 different pins of the TPS sensor and then open the throttle. You must find 2 pins that will not make any change to the measure when opening and closing the throttle body. One of these two pins must be connected to a 5V output from the ECU and the other one to the signal ground. The third pin is the TPS signal to the ECU.

The TPS signal voltage should vary according to the throttle opening, with voltage differences higher than 3V between fully closed and wide open throttle.

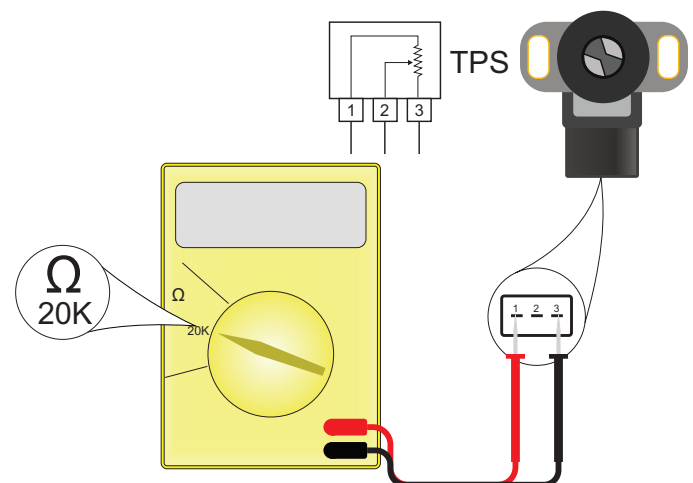

12.5 Crank trigger/RPM sensor

To control fuel and ignition, this ECU is able to read magnetic and Hall Effect sensors.

Distributor

To read RPM signal from a Hall Effect distributor, it should have a sensor with at least 3 pin and have the same number of reading windows (or "triggers") than the engine has number of cylinders.

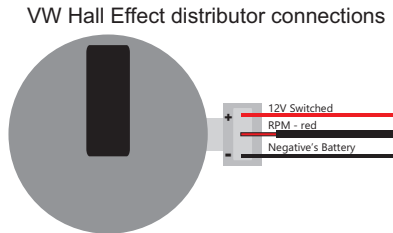

Crank trigger

The crankshaft trigger wheel is responsible for informing the exact position of the crankshaft to the electronic ignition management system, in such a way that this system is able to determine the ignition timing in the engine. The trigger wheel is installed on the crankshaft, outside or inside the engine block, with a specific alignment. Usually, the Crankshaft Trigger Wheels placed on the outside of the block are put in front of the engine, by the front crankshaft pulley, or in the rear of the engine, by the flywheel. There are many types of Trigger Wheels, but the compatible ones are mentioned below

60-2: this is, in general, the most used type of trigger wheel. It is a wheel with 58 teeth and a gap (fault point) equivalent to two missing teeth, therefore called "60-2". This trigger wheel is found in most Chevrolet (Corsa, Vectra, Omega, etc.), VW (Golf, AP TotalFlex, etc.), Fiat (Marea, Uno, Palio, etc.), Audi (A3, A4, etc.) and Renault (Clio, Scènic, etc.) Models, among other car makers. Ford Flex models with Marelli ECU use this type of trigger wheel also.

36-2: standard in Toyota engines, being 34 teeth and a gap equivalent to two missing teeth.

36-1: 35 teeth and a gap equivalent to one missing tooth. It can be found in all Ford vehicle lines, with 4 or 6 cylinders (except the Flex models with Marelli injection, which use the 60-2 trigger wheel).

12 teeth: this type is used by AEM's Engine Position Module (EPM) distributor. In this case, the CAM sensor from the EPM must be used. This distributor has 24 teeth, but as it rotates half-way for each full engine RPM, there will only be 12 teeth per RPM. Setup the Ignition with 12 teeth at crank (24 at CAM) and the 1st tooth alignment with 60°.

Setup ECU as 12 teeth (at crank) 24 (at cam) and use 60° for 1st tooth alignment.

Mitsubishi 1G CAS: due to the fact the CAM signal has two slots on this CAS, it's only possible to control the ignition on wasted spark mode and the fuel injection on multipoint or semi-sequential. No sequential fuel or ignition will work on this CAS with 2 slots on the CAM.

- **Pin 1** – white – CAM signal: connect to white wire from FT (connector A pin #17 to FT450 and FT550) and (connector B pin #4 to FT600).
- **Pin 2** – yellow – CRANK signal: connect to red wire from FT600 black shielded cable (Connector B - pin #1), from FT450/FT550 (connector A - pin #19)
- **Pin 3** – red – sensor feed: connect to a switched +12V
- **Pin 4** – black – sensor ground: connect directly to battery's negative.

FT setup: RPM signal "2 (crank) or 4 (CAM)" (4G63) or "3 (crank) or 6 (CAM)" (6G72), Hall Effect crank and CAM sensors, rising edge on both. Wasted spark ignition. 1st tooth alignment: 67.*

Mitsubishi 2G CAS: uses the same settings that 1G CAS, but has a sensor on the crankshaft (reading a 2 tooth trigger) and a CAM sync sensor.*



NOTE

This crank trigger will only work with a single tooth cam sync. On stock engines it is needed to remove the smaller tooth from the cam trigger wheel.

Crank trigger sensor:

- Pin 1: switched 12V
- Pin 2: CRANK signal: connect to red wire from FT450/FT550 (connector A - pin #19), from FT600 (connector B - pin #1)
- Pin 3: connect directly to battery's negative

CAM sync sensor:

- Pin 1: switched 12V
- Pin 2: CAM signal: connect to white wire from FT450 / FT550 (connector A - pin #17), from FT600 (connector - pin #4)
- Pin 3: connect directly to battery's negative

Ignition settings:

- **Stock Honda coil and igniter:** setup ignition as "Distributor – single coil" and select option "Rising edge (Honda distributor)". In this option, only the ignition output #1 will be active.
- **Multi coils and/or external igniter:** in this case, ignition can be controlled in wasted spark or sequential modes. Ignition output must be setup as "Honda distributor", but as Falling edge or Rising edge, according to the external igniter used.
- **1, 2, 3, 4, 5, 8, 10 and 24 teeth:** options available according to the number of engine cylinders. When having these trigger wheels, the use of a camshaft position sensor is mandatory, in order to maintain the synchronization of the parts. Also, the teeth must be equidistant. They can be found in models such as Subaru, Mitsubishi Lancer and 3000GT, GM S10 Vortec V6, etc.

Honda Distributor

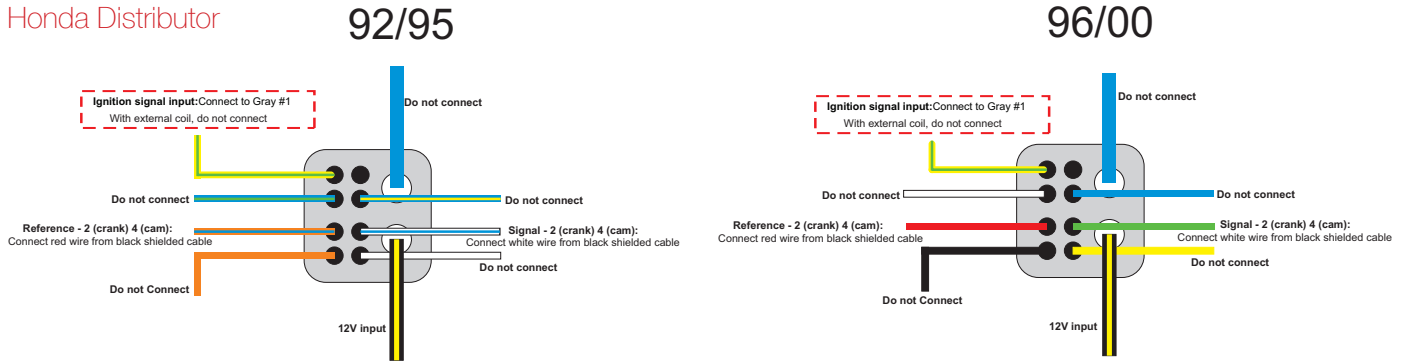

Distributor Pin	Honda 92/95 (Wire color)	Honda 96/00 (Wire color)	FT600 connection	Configuration
1	Yellow/green	Yellow/green	With OEM coil and igniter, connect gray #1 wire	With stock Honda coil and igniter: connect to gray wire #1 and setup as “Honda Distributor”. With multi-coils, and external igniter: do not connect
2	Blue/Green	White	Do not connect	
3	Orange/Blue	Red	Connect red wire from black shielded cable	Reference - 2 (crank) 4 (cam)
4	Orange	Black	Do not connect	
5	Blue/Yellow	Blue	Do not connect	
6	White/Blue	Green	Connect white wire from black shielded cable	Signal - 2 (crank) 4 (cam)
7	White	Yellow	Do not connect	
8	Blue	Blue	Do not connect	
9	Black/Yellow	Black/Yellow	12V input	12V input for OEM coil and igniter (inside the distributor) With external coil, do not connect

MSD distributor and crank trigger:

The distributors are equipped with VR/magnetic sensors e must be wired as the following:

- Orange/black: connected to the red wire of black shielded cable
- Purple/black: connected to the white wire of black shielded cable

Any mechanical or centrifugal advance must be locked. The crank trigger kits have different wire colors and the wiring must be as following:

- Purple: connected to the red wire of black shielded cable of FT600;
- Green: connected to the white wire of black shielded cable of FT600

The RPM signal settings must be:

- 4 cylinders: 2 (at crank) or 4 (at cam);
- 6 cylinders: 3 (at crank) or 6 (at cam);
- 8 cylinders: 4 (at crank) or 8 (at cam);

RPM sensor:

VR differential, rising edge, crank index position 45° (need to calibrate ignition with timing light)

Cam sync sensor:

Not utilized, unless you are running crank trigger and distributor (or a dedicated cam sync sensor) with a single tooth.

48-2, 30-2, 30-1, 24-2, 24-1, 15-2, 12-3, 12-2, 12-1, 12+1 and 4+1 teeth: These are less common types, but they are perfectly compatible. These trigger wheels can operate without a camshaft position sensor, as they have a gap that indicates the TDC on cylinder 1.

In order to correctly inform the engine position to the injection module, it is necessary that the injection has the right information about the alignment of the trigger wheel in relation to the TDC on cylinder 1. The image below shows a 60-2 trigger wheel with the sensor aligned on the 15th tooth after gap. In this image, for example, the engine is on the TDC on cylinder 1. Notice that the RPM is clockwise, and therefore, the TDC on cylinder 1 is set 15 teeth after the sensor passes the gap. That is exactly the number of teeth that must be informed to the injection upon its configuration.

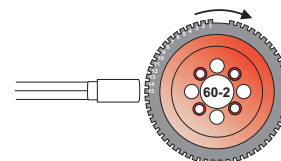

60-2 Trigger Wheel Aligned on the 15th tooth after the gap

Of the space in between them. The minimum diameter for the fabrication of a 60-2 trigger wheel is 125mm (5").

For 36-1 trigger wheels, the minimum diameter recommended is 100mm (4"). Trigger wheels with smaller diameters can be fabricated, but reading errors may occur and the engine may not work.

Crankshaft trigger sensor

When controlling the ignition with a trigger wheel, it is necessary to have a sensor that reads the signal from its teeth and informs the engine position to the injection. There are two types of crankshaft trigger sensors:

VR sensor: this is the type that is most commonly used in cars nowadays, especially with 60-2 and 36-1 trigger wheels. One of its main characteristics is that it does not receive 12V or 5V; it only generates an electromagnetic signal based on induction. It might have 2 or 3 wires (the third wire is an electromagnetic shield).

Hall Effect sensor: it is usually found on 2, 3 and 4-tooth trigger wheels and some 36-1 and 60-2 types. It receives a 5V or 12V feed and emits a square wave signal. It invariably has 3 pins: voltage, negative and signal.

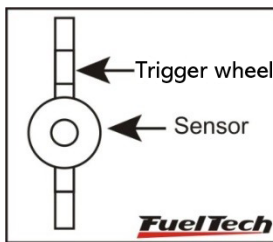

The crank Wheel should be aligned with the sensor



NOTE

If a VR sensor doesn't pick up RPM signal, try to swap the sensor wires (red and white wires). Or install resistor of 560ohms between red and white wires.

A very simple test using a tester can identify if a Crankshaft Trigger Sensor is an inductive or a Hall Effect sensor. Turn the tester on the resistance measurement mode at a 2000Ω scale and connect its probes to the sensor's pins. Test pin 1 with the other two. If a resistance of 600-1200Ω is found, the sensor tested is of inductive type.

If no resistance is found among any of the pins, or if the resistance found is much higher than 1200Ω, it is either a Hall Effect sensor, or an inductive sensor with a broken coil. Notice that, when finding the resistance between pins 2 and 3, for example, pin 1 must be connected to the battery's negative terminal and the other 2 to FT shielded cable. If the module does not capture the signal, invert the white and red wires connections.

12.6 Camshaft position sensor

This sensor tells the ECU when the cylinder #1 is reaching its TDC on the compression stroke. With this information it is possible to control ignition and fuel injection in sequential mode. Installation and alignment of this sensor are pretty simple. The only

requirement is that this sensor is triggered before the crank trigger sensor goes through the gap on the crank trigger wheel.

12.7 O2 sensor

Wideband O2 sensor

The use of wideband lambda sensors on ECUs input requires an external conditioner (WB-O2 Slim or WB-O2 Datalogger). It is important to verify the measurement range of conditioner analog output, as this will be informed during the configuration of ECUs O2 input (0,65-1,30, 0,65-4,00 or 0,65 to 9,99)

Narrowband O2 sensors

Although less precise than the wideband lambda sensor, narrowband O2 sensors can be connected to the ECU input for the display of values (in Volts) at the Dashboard and at the Diagnostic Panel. Narrowband O2 sensors usually follow a standard set of colors, facilitating the wiring. The table below shows the wiring instructions based on the color scheme generally used for O2 sensor wires:

Wire Color	4-wire O2 sensor	3-wire O2 sensor	1-wire
Black	Signal Output	Signal Output	Signal
White (2 wires)	Switched 12V and ground (connect one wire onto the 12V and the other to ground – there is no polarity)		Not featured
Gray	Battery's negative terminal	Not featured	Not featured

As a general rule, if there are two wires with the same color, one is the switched 12V and the other is the ground. After connecting the O2 sensor to the ECU, the O2 sensor input must be set up as guides chapter 15.5.

12.8 Step motor – idle speed

Its control is done through the four yellow outputs of the connector A, also used for electronic throttle control. After selecting the idle speed control as step motor the four yellow outputs are automatically set up as "step motor" on the harness connection table. Below are some known step motor connections.

VW stepper motor - Magneti Marelli

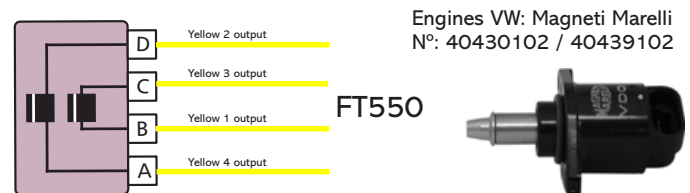

GM stepper motor - Delphi

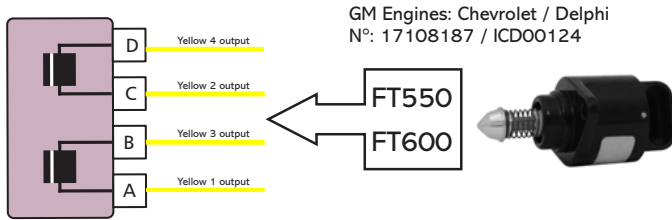
**IMPORTANT**

Step motor is calibrated every time the ECU is turned on, so, before cranking the engine, it is recommended to wait about 2s after turning the ignition switch on. If this procedure is not respected, the engine may be revved up unwittingly during the step motor calibration, coming back to normal within seconds.

If your step motor is different from the ones listed here, do what follows:

1. Put a tester on the 200 Ohms range;
2. Measure the step motor actuators until you find a resistance of approximately 50 Ohms. That's one pair of coils;
3. Connect yellow #1 and yellow #3 to a pair of coils and yellow #2 and yellow #4 to the other pair.;
4. If the step motor remains fully opened after the calibration, change yellow #1 by yellow #3 position.

FT600 step motor control is compatible with the great majority of actuators nowadays.

Usually, with this simple test you're able to make the step motor work normally.

13. Auxiliary outputs

The installation of a fuse equivalent to the charge is recommended. The auxiliary outputs have an overload protection system, with automatic current cut-off. They trigger the charges (lamps, relays, etc.) With a negative signal. Thus, the positive terminal must be connected to a switched 12V.

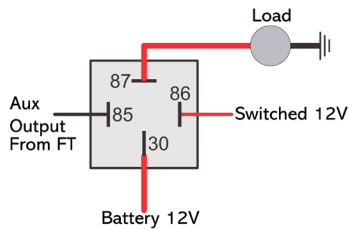

The auxiliary outputs must be set manually according to the desired function in the outputs (blue, gray or yellow wires) that are not being used as injector or ignition outputs.

In case of having back current and keeping relays switched on with ECU powered off, use a 1N4004 diode.

Each output must be configured in accordance to its function.

For more information about the outputs programming, see chapter 19.

13.1 Cooling fan 1 and 2

This output is responsible for switching an electric fan according to the module's settings. The relay used must be adequate to the electric fan's current (50A, for example). The relay is switched by negative (sourced by the output), and the positive a switched 12V.

Important Note: the electric fan must not be connected directly to the auxiliary output without the use of a relay; otherwise, the output will be damaged.

13.2 Idle valve

This function opens a valve which increases the air flow in the intake, helping the engine to idle.

We recommend normally closed valves, such as boost or purge (EVAP) solenoids.

An appropriate relay must be used according to current and voltage. The FT output switches ground and the 12V must be a switched 12V.

13.3 Air conditioning

This auxiliary output option allows for a much more intelligent control of the vehicle's air conditioning compressor, as the FT controls its activation only when the engine is already on and the idle speed has stabilized and turns off the air conditioning when the valve exceeds a predetermined value (a resource commonly used in low-powered engines).

A/C button

In order to have the air conditioning control, the A/C button on the dashboard must be connected to a white input of FT. The two connection options are:

A/C button positive when ON

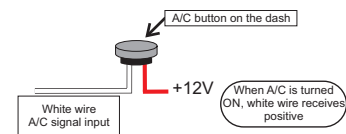

A/C button negative when ON

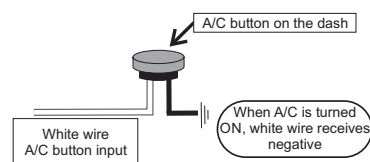

The air conditioning will remain turned on as long as the A/C Signal Input receives signal from the button. The signal polarity can be chosen and it varies depending on the installation.

A/C Compressor

A/C compressor must be controlled with a relay, triggered by an auxiliary output (sends negative when activated).

The auxiliary output that was setup as A/C will activate the A/C compressor relay and the A/C fan. For more information on how to setup this output, check chapter 13.

13.4 Shift Alert

This function activates an external shift light and works by sending negative when turned on. Any of the options below can be used:

- 12V light: switched 12V directly connected to the light bulb and the negative connected to the blue or yellow outputs.
- LED working as a Shift Light, which must be connected with a serial resistance (if used in 12V, resistance from 390Ω to 1kΩ) to the switched 12V.
- Any "Pen" Shift Light – working in the same way as a light bulb.

13.5 Fuel pump

The fuel pump control must be done through a relay sized in accordance to the pump's working current. The output sends out negative to activate the relay, which stays activated for 6 seconds and turns itself off if the ECU does not receive any RPM signal. When the ECU reads RPM signal, it activates the fuel pump once again.

13.6 Variable camshaft control/Powerglide gearbox

The camshaft control systems that use solenoid valve type NO/NC such as Honda's VTEC can be controlled through this output. The user only needs to inform the solenoid's turn on RPM.

It is important to notice that the impedance of the variable control system's solenoid must respect the auxiliary output limits, which

requires a minimum impedance of 25Ω, or the use of a relay. For valve timing control systems switched by PWM (such as Toyota's WTi), it is possible to manage it through the Boost Control function, as long as its characteristics (power, current, etc.) are within the auxiliary output limits.

This resource can also be used to switch the control solenoid from the 2-speed automatic gear control, Powerglide type. Configure the RPM to turn on the solenoid responsible for engaging the second gear, only for drag racing applications.

13.7 Progressive nitrous control

This function drives the solenoids used for the injection of nitrous oxide in the engine.

As these solenoids have high power (90W) and low impedance (~1.6Ω), they cannot be connected directly to the auxiliary output. A solid state relay with appropriate max current and voltage must be used to power the nitro and fuel solenoids.

Set the output as progressive nitrous output.

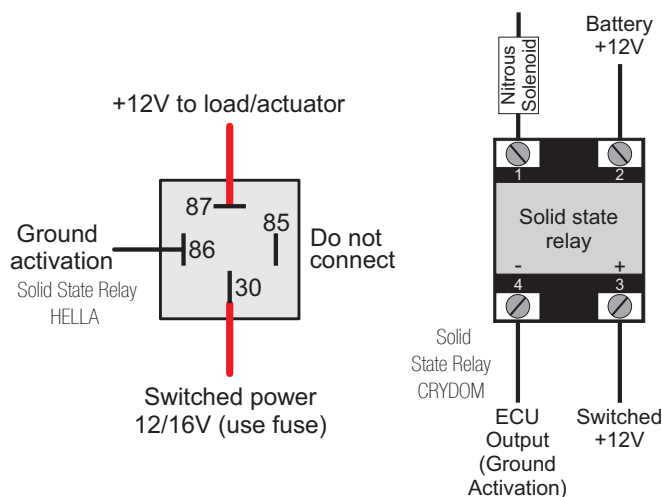

In the second option, the fogger only injects nitrous (dry nitrous). Fuel enrichment is managed by the injection, increasing injection times based on what has been programmed. The dry nitrous system has reached better results in tests, giving the engine a more linear power than the first option. It is important to clarify that in order to use the dry nitrous system, the fuel injectors must be correctly sized for the power maximum with the nitrous system operating.

There is a difference in the operation of solenoids that control nitrous injection and the ones that control fuel injection: nitrous solenoid starts pulsing after 5%; fuel solenoid only pulses after 20%. Variations may occur among solenoids from different brands/manufacturers.

When applying the conventional nitrous control, one must start with a minimum injection time of 20%, but when using dry nitrous, it is possible to start with 5%, as the injectors – and not the solenoid – will control fuel injection.

13.8 Boost Control – N75

This auxiliary output configuration allows the driving of a boost pressure control solenoid. FuelTech recommends using a 3-way N75 solenoid, found in the original 4 and 5-cylinder

VW/Audi Turbo models, which can be directly switched through the auxiliary output. Such solenoid valve controls the pressure on the top and bottom parts of the wastegate valve, changing the engine manifold pressure with which the latter opens.



N75 Solenoid Valve
VW 058-906-283F

Wastegate at the exhaust manifold

This type of valve is used on most cars with adapted turbo, in competitions, etc.

Example 1: the first way to install a boost valve is connecting it to the bottom of wastegate valve, similar to the OEM installing in the VW 1.8T. Select the output signal as activated at 0V and frequency at 20Hz.

This way the boost valve will decrease the pressure under the wastegate to increase boost pressure.

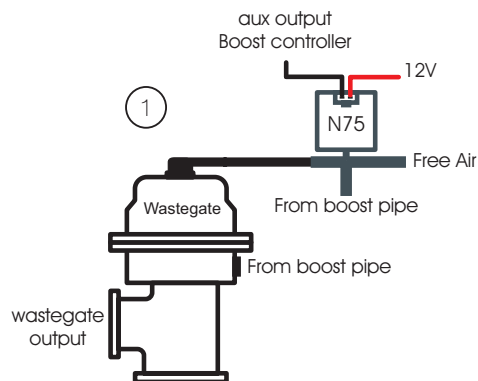

Example 2: the second way is to connect the boost solenoid to the top of wastegate.

Select the output signal as activated at 12V and frequency at 20Hz. This way, the boost valve will increase the pressure at the top of wastegate to increase boost

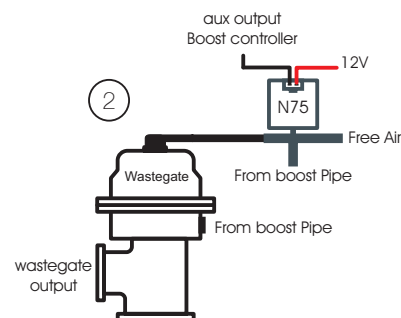

Wastegate integrated to the turbine

This valve has a different operation system, as it relieves the boost pressure when pressure is put on its top part, which is the opposite of what happens to the wastegate installed at the exhaust manifold.

Select the output signal as activated at 0V and frequency at 20Hz
 With this kind of wastegate, the boost valve relieves the pressure in top of wastegate to increase boost pressure

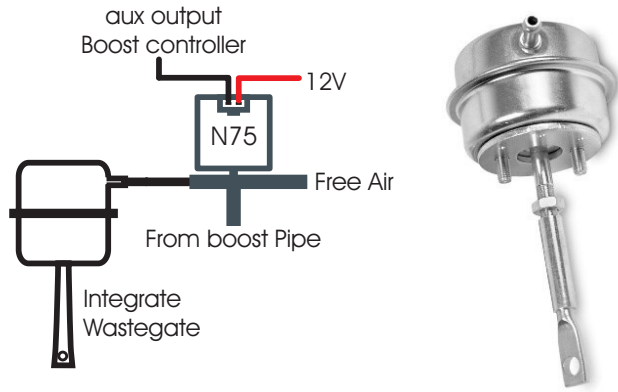

13.9 BoostController

The BoostController is used for more precise control of the turbo pressure in street cars, circuit and drag races. The control can be performed by time after 2-step, RPM and gear, gear and time after change, unique value and engine RPM, as well as the control with specific targets for drag race (2-step, 3-step and burnout).

See more information in chapter 19.15 BoostController diagrams.

14. Electronic throttle control

14.1 Electronic throttle control (FT600)

Electrical installation of an electronic throttle on FT600 is pretty simple. Check the example diagram below:

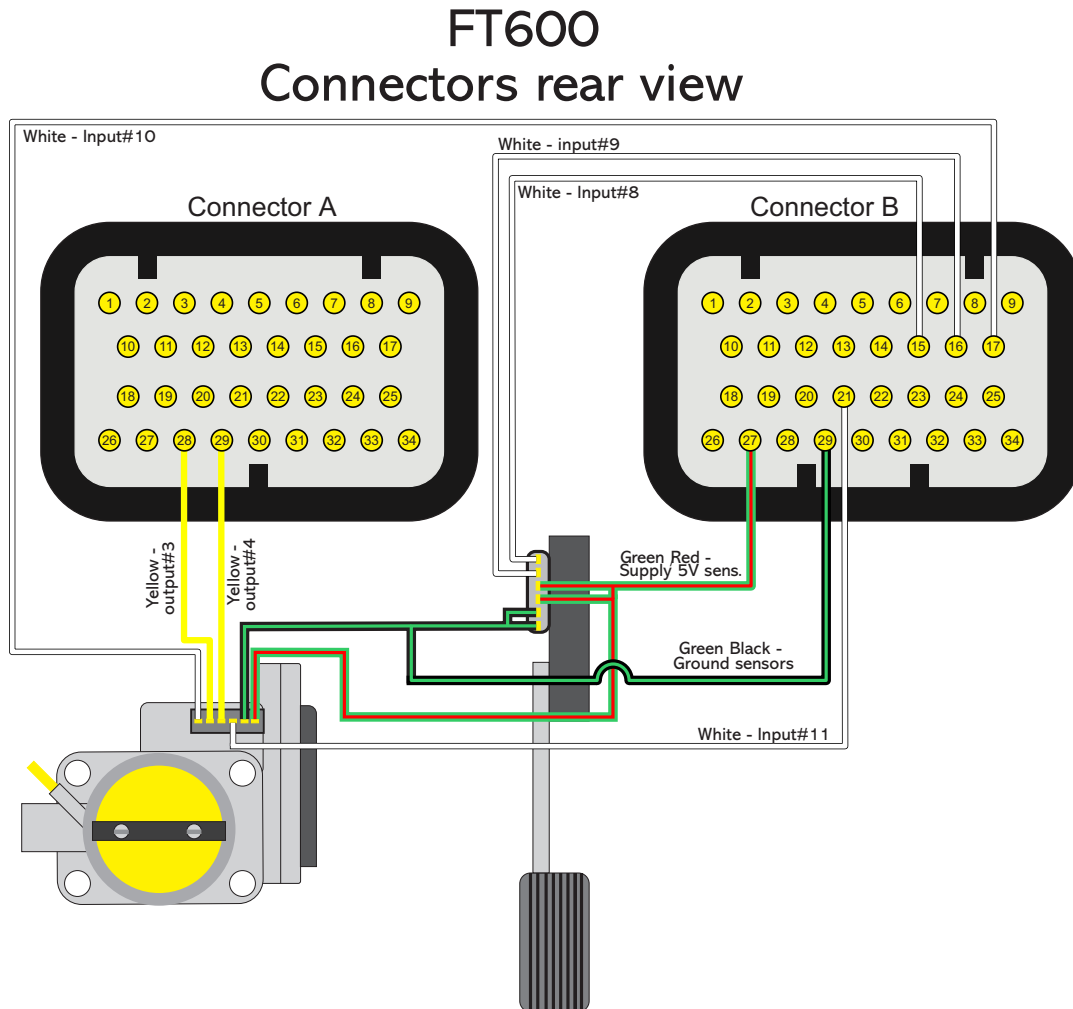

- **Yellow wire #3** (pin 28 of the connector A) must be connected to the throttle input corresponding to the Motor 1 input.
- **Yellow wire #4** (pin 29 of the connector A) must be connected to the throttle input corresponding to the Motor 1 input.
- **Green/red wire** (connector B) is and 5V output used to feed throttle and pedal position sensors. It must be spliced and connected to both of them.
- Sensors negative can also be spliced between pedal and throttle position sensors. Connect it directly to the battery's negative terminal.
- White numbered wires are sensors signal inputs, connect them to the signal outputs of the pedal (Pedal 1 and Pedal 2) and throttle (TPS1 and TPS2). After connecting these inputs, it is necessary to calibrate throttle and pedal as guides chapter 15.1.
- Pins 28 and 29 (connector A), yellow wires, will not be used for electronic throttle control, they can be set up as auxiliary outputs..

14.2 Connection – throttle bodies and pedals

Check the throttle and pedal wiring before disconnect it from the OEM ECU. If you need, contact our tech support to get more information about throttles and pedals.

With the electrical connections ready, go back to chapter 7.5 and insert the throttle code (FT) that you found on the throttle table connection

If your throttle is not listed in our table, it might be necessary to send it to our tech team to have them check compatibility and research its control parameters. In this case please contact our tech support.

14.3 Electronic throttle control (FT550 / LITE)

FT550 Connectors rear view

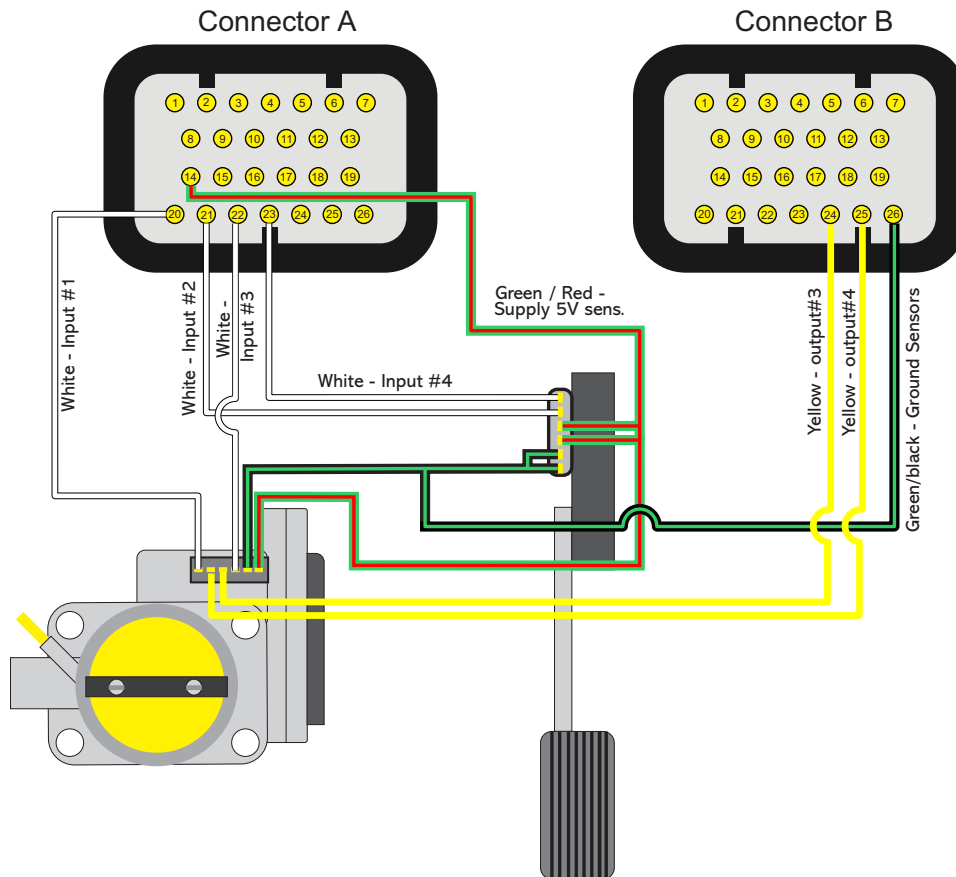

- **Yellow wire #3** (pin 24 of the connector B) must be connected to the throttle input corresponding to the Motor 1 input..
- **Yellow wire #4** (pin 25 of the connector B) must be connected to the throttle input corresponding to the Motor 1 input.
- **Green/red wire** (pin 14 of the connector A) is and 5V output used to feed throttle and pedal position sensors. It must be spliced and connected to both of them.
- **Green/Black** (pin 26 the connector B) Sensors negative can also be spliced between pedal and throttle position sensors. Connect it directly to the battery's negative terminal.
- White numbered wires are sensors signal inputs, connect them to the signal outputs of the pedal (Pedal 1 and Pedal 2) and throttle (TPS1 and TPS2). After connecting these inputs, it is necessary to calibrate throttle and pedal as guides chapter 15.2.
- Pins 24 and 25 (connector A), yellow wires, will not be used for electronic throttle control, they can be set up as auxiliary outputs.

14.4 Connection – throttle bodies and pedals

Check the throttle and pedal wiring before disconnect it from the OEM ECU. If you need, contact our tech support to get more information about throttles and pedals.

With the electrical connections ready, go back to chapter 7.5 and insert the throttle code (FT) that you found on the throttle table connection

If your throttle is not listed in our table, it might be necessary to send it to our tech team to have them check compatibility and research its control parameters. In this case please contact our tech support.

15. Sensors and Calibration

This chapter has the final steps before the first engine start. It basically guides the user through checking sensor readings and calibrating engine actuators.

15.1 Ignition calibration

The ignition calibration screen on FT has the same parameters that previous FT ECUs, the difference is that they are in the same screen. After calibrating the ignition, the 1st tooth index position is automatically changed on the "Engine setup" menu.

When using distributor, the ignition must be calibrated on this screen, instead of turning the distributor.

Ignition calibration screen: FTManager in FT

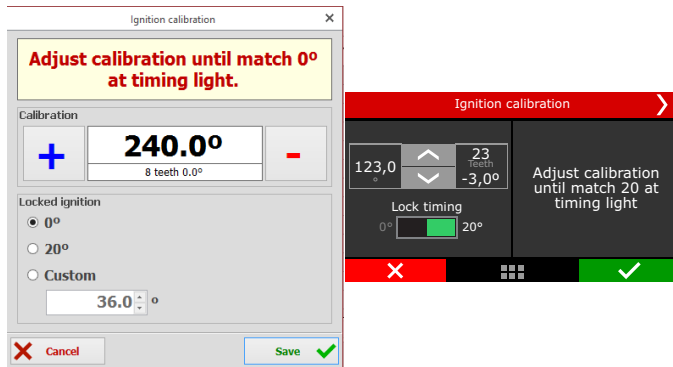

15.2 TPS calibration

Through FTManager, click in the TPS/Pedal button



IMPORTANT

To perform this calibration, it is very important that the engine is not running, because the throttle is fully opened and closed

Go to "Sensors and calibrations" and then "Calibrate throttle/pedal".

1. With the pedal on idle position, click button "calibrate" beside the field "Idle: 0%
2. Push throttle to the maximum and click "calibrate" button beside the field "WOT: 100%".
3. Press "Save". Message "Calibration done!" is shown if the process is OK.
4. In case an error message is shown, check TPS connections.

TPS calibration errors may be:

Inverted and calibrated: means the TPS is connected the wrong way, but is working normally. Double check connections, but, know that it will work normally connected this way.

Possibly disconnected: check TPS connections. Maybe there is a broken wire or one of the connectors does not reach the TPS pins.

Check with a tester to see if the voltage on the orange wire varies according to the throttle position.

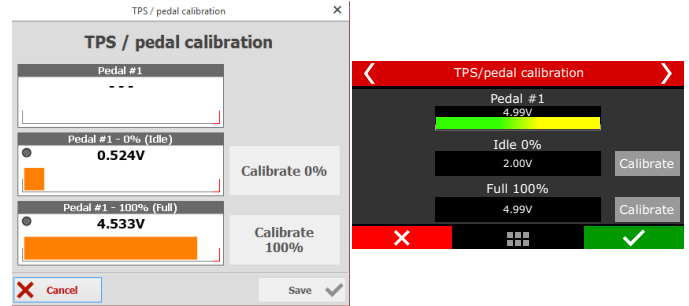

TPS sensor must be calibrated on the first time the ECU is turned on only, and should be recalibrate only when it has to be replaced or the throttle opening on idle was changed. TPS calibrations are individual by map file.

TPS signal voltage must go up, as the pedal is pressed, and must have at least a 3V difference between the idle and WOT positions

TPS errors and diagnostics

Error message	Diagnostic
TPS range must be higher than 1.5 Volts	The TPS value from 0% to 100% has a smaller difference than 1,5V
TPS signal may be shorted to ground	Ground short circuit for TPS input
TPS signal may be disconnected	TPS input disconnected or short circuited to 5V
TPS calibration is required only when activated	No input configured as TPS.

15.3 Electronic throttle/pedal calibration

This calibration procedure is exactly the same as the mechanical throttle calibration. The only difference is that the calibration screen shows voltage value on both TPSs of the electronic pedal.

With this done, it is necessary to adjust idle speed control parameters as guides chapter 19.2



IMPORTANT

Every time the pedal calibration is done the throttle automatically calibrates its opening limits. It is very important that during this calibration the engine is turned off because the throttle is fully opened and closed.

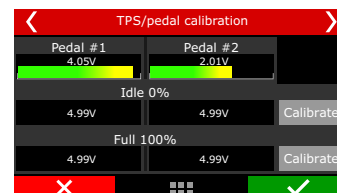

Throttle body error and diagnostic messages

Error Message	Diagnostic
Throttle #1 channels not found	There is no input configured as throttle input
ETC motor #1 signals may be disconnected	ECU Failed to actuate the throttle motor
Throttle #1A signal may be shorted to ground	Throttle Input A short circuited to GND
Throttle #1A signal may be disconnected	Throttle input A disconnected or short circuited to 5V
Throttle #1B signal may be shorted to ground	Throttle Input A short circuited to GND
Throttle #1B signal may be disconnected	Throttle input A disconnected or short circuited to 5V
ETC 1 code error	Throttle code error

Electronic Throttle security behaviors

Correlation error between throttle and pedal signals

- Happens when the difference between pedal and throttle is higher than 20% for more than 200ms
- The electronic throttle is turned off and returns 500ms after the difference between the signals is below 20%.

ETC position tracking error

- Happens when the difference between the desired position and the throttle position is higher than 10% for more than 1 second
- The electronic throttle control is turned off and only returns 0,5s after the difference between the desired position and the throttle position is lower than 10%

15.4 Fuel/oil pressure sensors inputs

In this menu are the settings for fuel and pressure sensors. There is a predefined configuration for PS- 150/300/1500 pressure sensors, but any kind of analog sensor with 0-5V signal can be used. This configuration is done through the PC and software FTManager.

In case there is a reading error between the FT screen and the real value of the sensor (comparing to an external gauge), this compensation is easily done by adjusting the sensor offset. It is possible to edit this compensation in mV or in pressure offset. Just change the button on the top part of the screen between "Input value" (mV adjust) and "Output value" (pressure offset). The field "Read value" shows readings in real time.

Make sure your external gauge is correctly calibrated and that the correct sensor is selected, as incorrect use of this function can cause significant error in pressures reported.

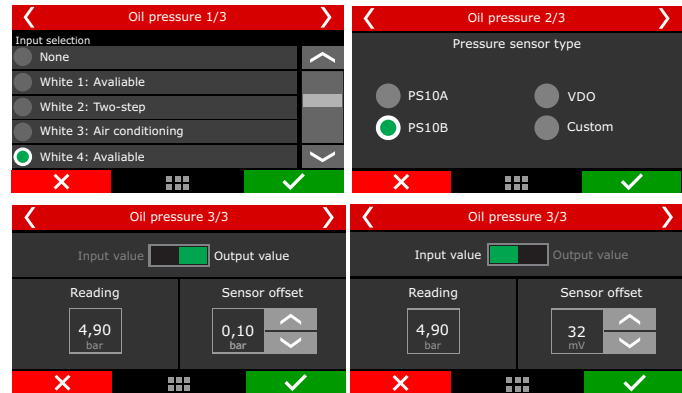
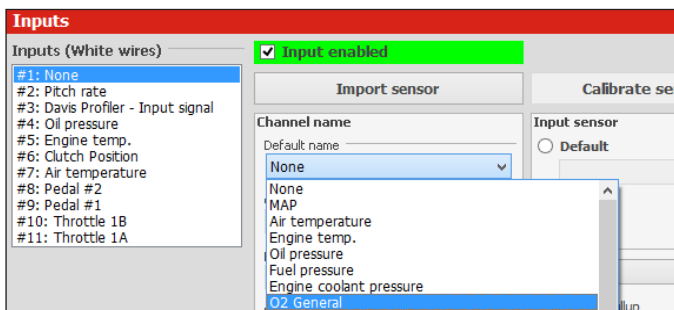

The FT has fully customizable inputs, which allows to read any 0-5V analog pressure sensor, since its pressure vs voltage table is known. In this case, just select the custom option and fill the interpolation table through FTManager.

15.5 Intake air and engine temperature sensors

In this menu are the settings for intake air and engine temperature sensors. There is a predefined configuration for GM and Fiat sensors.

In case there is a reading error between the FT and the real value of the sensor (comparing to an external gauge or to the dashboard), this compensation is easily done by adjusting the sensor offset. It is possible to edit this compensation in mV or in degrees. Just change the button on the top part of the screen between "Input value" (mV adjust) and "Output value" (temperature offset). The field "Read value" shows readings in real time.

Make sure your external gauge or dashboard is correctly calibrated and that the correct sensor is selected, as incorrect use of this option can cause significant error in reported temperatures and possible engine damage

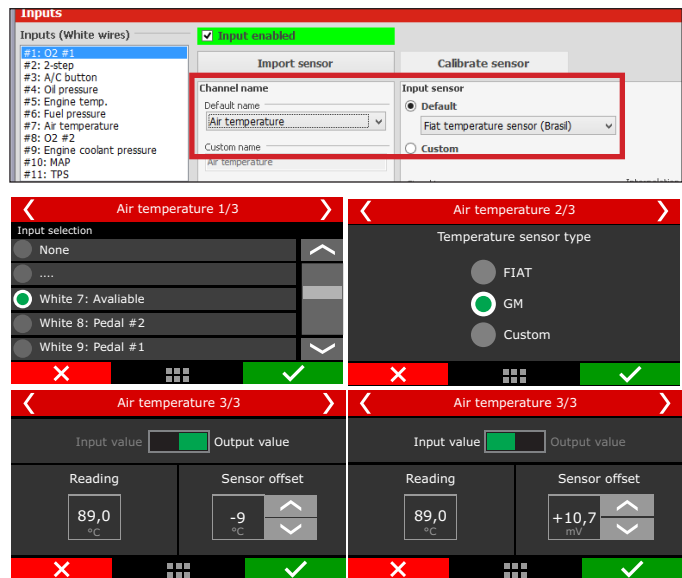

The FT has fully customizable inputs, which allows to read any 0-5V analog temperature sensor, since its temperature vs voltage table is known. In this case, just select the custom option and fill the interpolation table through FTManager.

15.6 O2 sensor inputs

O2 sensor signal input can be setup on any sensors input of this FT it is even possible to read fifteen O2 sensors simultaneously and show them on the screen. For wide band O2 sensors, it is necessary to use a wide band conditioner, for narrow band O2 sensors, direct connection is allowed.

Be sure to connect the O2 conditioner to FT according to the Chapter 12.7 of this manual.

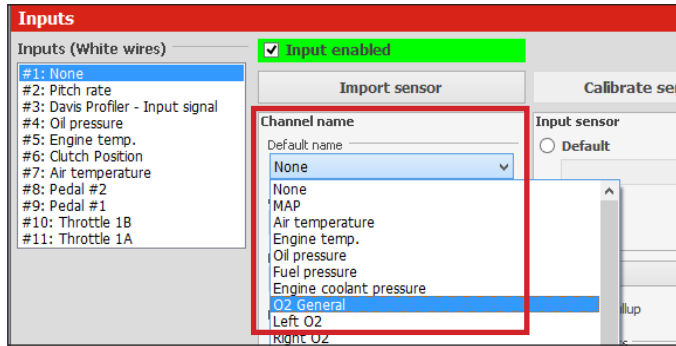

CAN network reading

Through CAN network the reading is sent directly to FT, the only configuration necessary is to indicate what is the position of each sensor, this procedure is called "association".

The association procedure is executed by disconnecting from the conditioner a single sensor at time, this way the FT identifies and associates that sensor to the position of the engine (cylinder 1, general O2 sensor).

Follow the steps and repeat for each O2 sensor:

1. Keep the conditioner connected and turned on and disconnect the O2 sensor;
2. Press the Associate button on FT or on the "CAN communication of FTManager" window;
3. Reconnect the O2 sensor and repeat the process for all other O2 sensors;

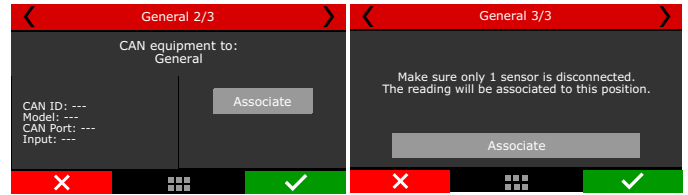
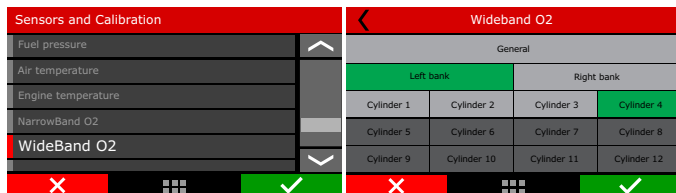
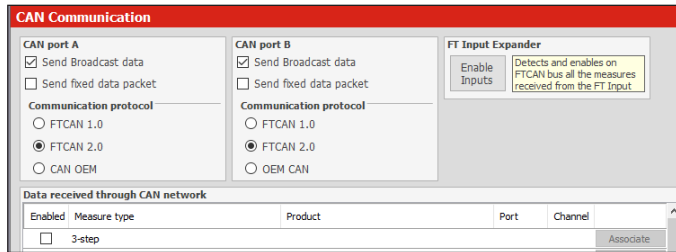

Analog input reading

The O2 sensor reading through an analog input is used either to narrow band or wide band with conditioners that have analog output (FuelTech WB-O2 Slim WB-O2 Nano WB-O2 Datalogger and Alcohol O2), Simply set the sensor in any input of FT (white wires).

It's necessary to set the input scale according to the analog output of conditioner used. If it's a FuelTech conditioner select one of the preset scales. For other manufacturers use the custom table. The narrow band sensor reading is displayed directly in Volts.

Analog scales compatible with the FT are:

Scale	Output voltage
0,35 - 1,20	0,35 = 0,2V - 1,20 = 4,8V
0,59 - 1,10	0,59 = 0,2V - 1,10 = 4,8V
0,65 - 1,30	0,65 = 0,2V - 1,30 = 4,8V
0,65 - 4,00	0,65 = 0,2V - 4,00 = 4,8V
0,65 - 9,99	0,65 = 0,2V - 9,99 = 4,8V

WB-O2 Nano, Slim or Datalogger calibration

Offset calibration is needed to compensate analog signal loss. With O2 sensor connected and configured go to "Calibrate O2 sensor" (through display) or click in "Calibrate sensor" in FTManager software.

To calibrate O2 sensor, proceed as follows:

1. Check the scale of FT with external conditioner, they must be equal.
2. With the engine running, stabilize the O2 reading.
3. Adjust the offset until the reading in the conditioner matches the reading in the ECU.



4. If the calibration and configuration are correct, there will be no reading difference.



NOTE

If the difference is greater than 0.02 between the readings, it means that the scales are different.

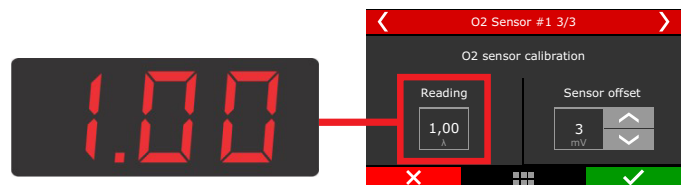

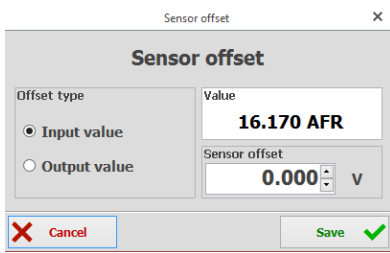

Alcohol-O2 Calibration

Also called free air calibration, this calibration is necessary when using FuelTech Alcohol O2 conditioner to compensate for differences in each sensor. When replacing a sensor it's necessary to repeat this calibration.

1. Remove the sensor from the exhaust pipe and let it ventilate for at least 20 seconds;
2. Press the calibrate button;
3. Calibration is OK;

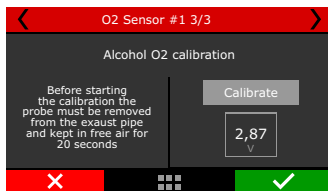

15.7 Speed inputs

In the FTManager, there is a menu with all the settings related to wheel speed reading. In the touchscreen, the settings are divided in a few sub menus and will be presented in the next chapters.

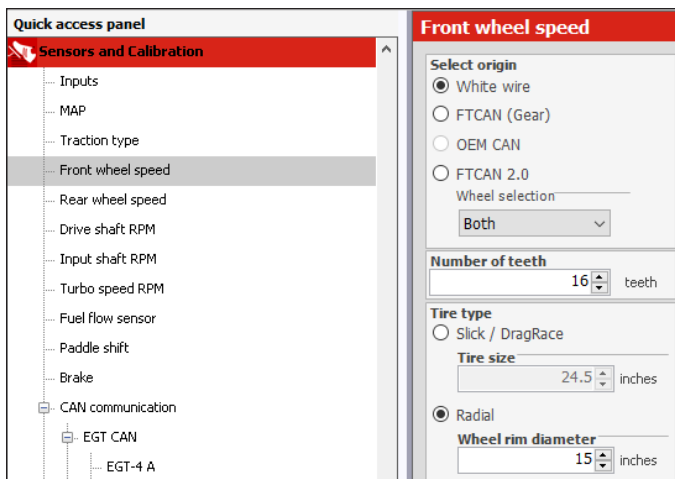

Select Origin

Select on the first screen if wheel speed information will be read using ECU analog inputs (white wires), using GearController information over CAN bus (FTCAN 2.0), or using OEM CAN and FTCAN 2.0 (FT Input Expander).

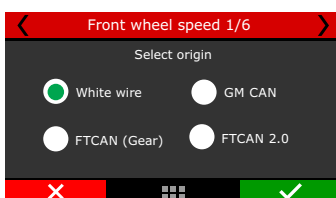

If the chosen option is "White wire", the configuration screens will be shown to set the sensor input to left and right wheels, and number of teeth. The next screens will not be displayed when the CAN option is chosen.

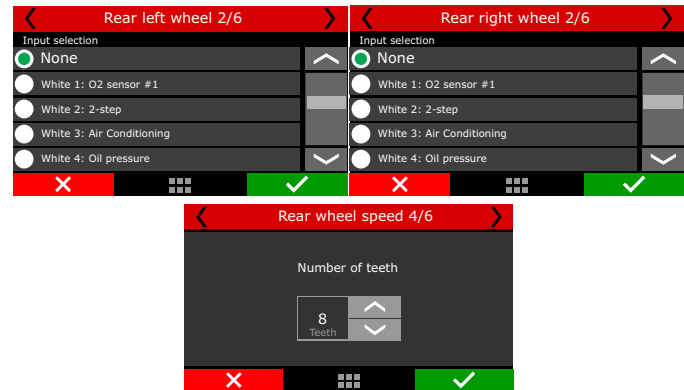

The last setting is related to tire type and size. Slick/Drag Race tires only require the wheel rim diameter. Radial tires require wheel rim diameter, tire width and height.

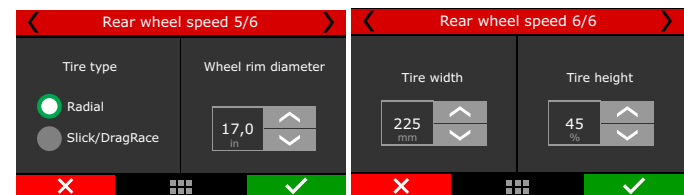

15.8 Driveshaft RPM

In the FTManager, there is a menu with all the settings related to driveshaft RPM and input shaft RPM reading. In the touchscreen, the settings are divided in a few sub menus and will be presented in the next chapters.

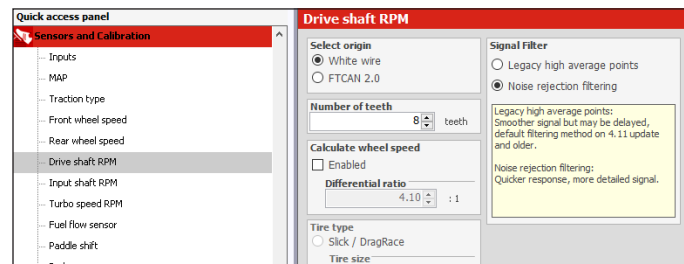

This menu is used to setup the driveshaft RPM reading. Select the FT600 sensor input to be used and insert the trigger wheel number of teeth



With the driveshaft speed and the tire dimensions, it is possible to calculate the traction wheel speed. If you want to use a driveshaft RPM sensor instead of a wheel speed sensor, check the box "Calculate wheel speed" in the next screen.

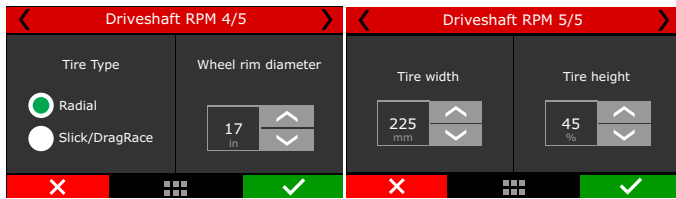

To calculate wheel speed, insert the differential ratio and tire dimensions.

The last setting is related to tire type and size. Slick/Drag Race tires only require the wheel rim diameter. Radial tires require wheel rim diameter, tire width and height.

15.9 Input shaft RPM

This feature allows the gearbox input shaft RPM Reading. The reading is very useful to analyze the clutch/torque converter slip. Just insert the sensor input and the number of teeth



15.10 MAP Sensor

This menu allows to setup the internal MAP or an external one.

Internal MAP: Can read up to 87 PSI and it's average points and Q factor can be changed for smoother readings on engines with high cam profiles.

External MAP: Can usually read pressures higher than 87 PSI, a white input must be used to setup an external MAP sensor for more than 87 psi.

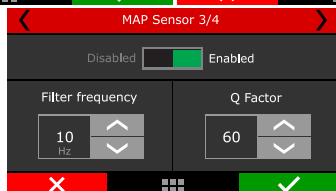
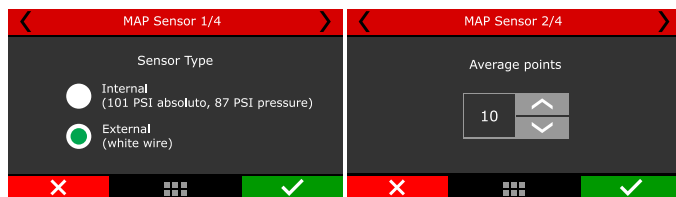
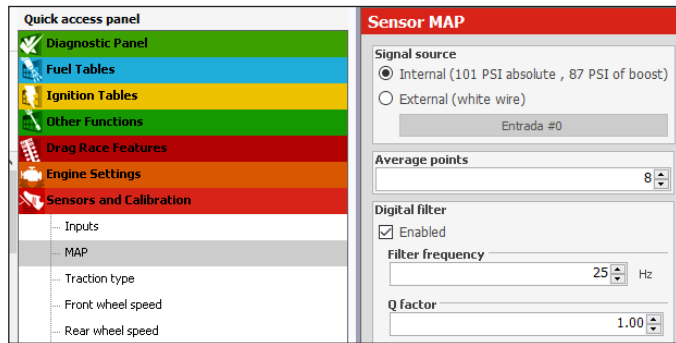

15.11 Gear detection

In this menu there are the settings related to gear detection change (display and log). There are 10 different ways to detect it: by RPM drop (drag race only), by gear position sensor (requires a sensor in the transmission), by interpolating the current wheel speed versus engine RPM, by pulse and by gear shift output.

To view the currently engaged gear in the FT dashboard, go to "Interface Settings" and then "Dashboard Settings". Once in, click in the cell where you want to display the gear and select "Gear".

The first mode, by RPM drop, must be used only in drag race cars, since it can only detect upshifts and not down shifts. The third screen is for safety configurations, used to prevent false gear detection due to traction loss. Default values are good to most cases.

The fourth screen is for the RPM drop programming to each gear. The fifth screen is to enable and program the timeout for gear shift detection that is another safety feature to prevent false detection.

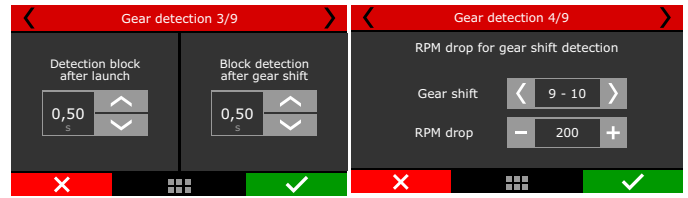
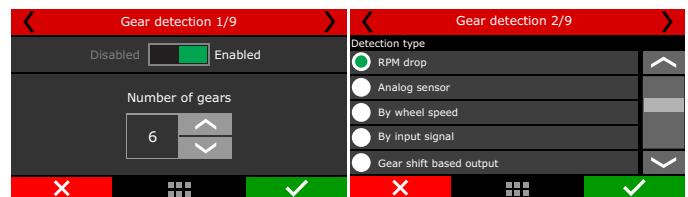
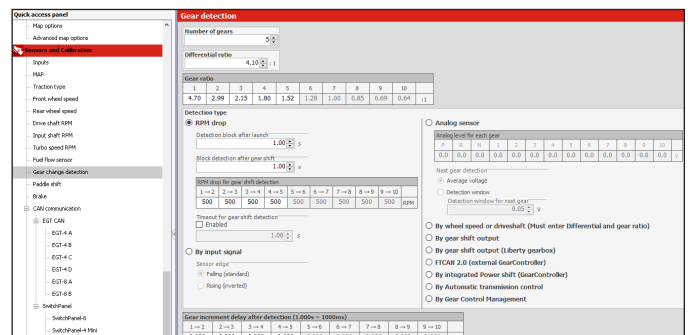

The second mode reads an analog gear position sensor, which is a potentiometer that indicates the engaged gear in transmissions already equipped with this sensor. Select the input that will read the sensor signal and then configure each gear voltage

To find the gear voltage, use a multimeter, in 20VDC scale, connected to the output of the gear position sensor and engage a gear at a time.

Intermediate voltage: uses the voltage reading between the levels configured to detect gear shift.

Adjustable window: set a voltage window for the gear shift detection to happen.

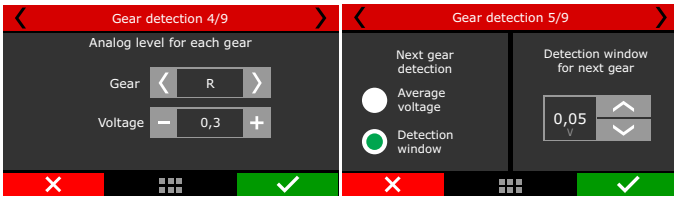

The third mode crosses the wheel speed and RPM to calculate the engaged gear.

To configure, set the number of gears, gearbox ratio and differential ratio.

This detection mode will only show the engaged gear if the vehicle is moving and there is wheel speed reading.

When the clutch is pressed or the gear is disengaged (neutral) your FT may display an incorrect gear momentarily.

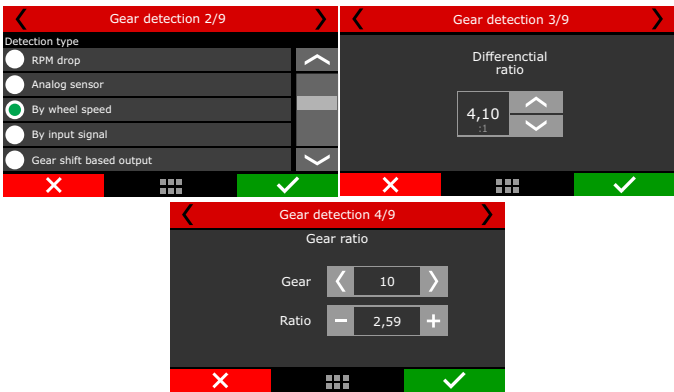

The fourth mode increases the gear counting by each pulse received on a white input. Set in which edge the count should be increased (default: falling edge). Configure an input as "Gear Detection" and connect the device that will send the pulse to increase the counting. This mode cannot detect down shifts and requires the 2-step to be used to reset the counter; therefore it is best suited for drag race cars.

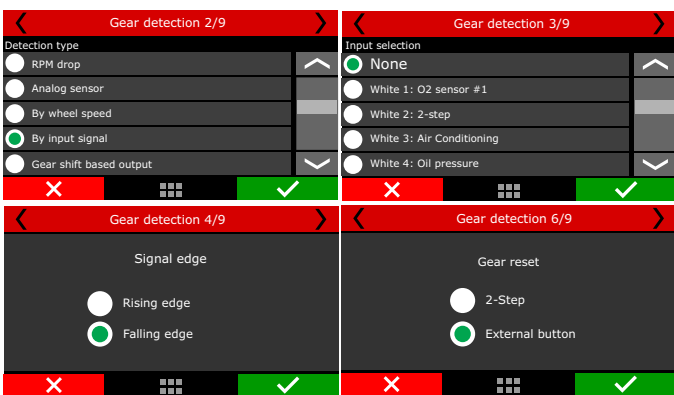

The fifth mode enables an internal counter that is increased by each pulse sent out by the Gear shift output (Drag Race Features menu). This mode cannot detect down shifts and requires the 2-step to be used to reset the counter; therefore it is best suited for drag race cars.



The sixth mode of gear detection uses the "Gear shift output (Liberty gearbox)" and is specially designed for drag racing vehicles using Liberty Gearboxes. Set inputs for detection of Reverse and Drive switches and if necessary, set gear increment delays.

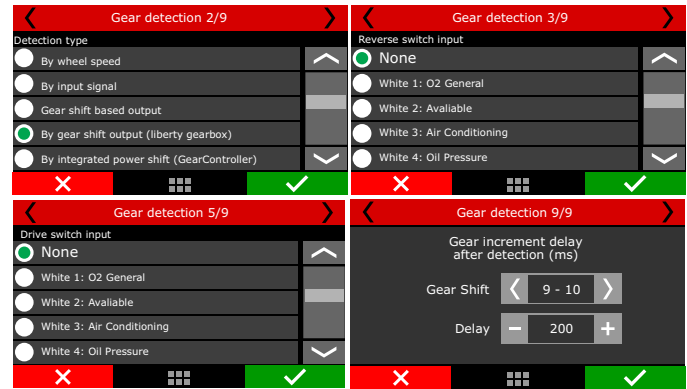

The seventh option is FTCAN 2.0 and it must be selected whenever an external GearController is used. There is also an option to setup gear increment delays for each gear, to make gear compensation tables match and start at the exact same time as the actual gear is engaged.

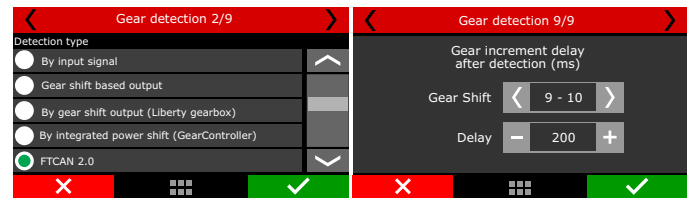

15.12 Nitrous bottle pressure

This menu gathers the settings to read nitrous bottle pressure. This way is possible do compensate fuel according to the bottle pressure. To read the bottle pressure you must use a PS1500 sensor or a similar one.

15.13 Clutch position

In this menu are the settings to read the clutch position. A potentiometer must be used, similar to a TPS. After the wiring done, the calibration is required.



15.14 Clutch pressure

This function allows to measure the pressure of the liquid on hydraulic assisted clutches. To read the pressure, use a PS1500 sensor or a similar one.

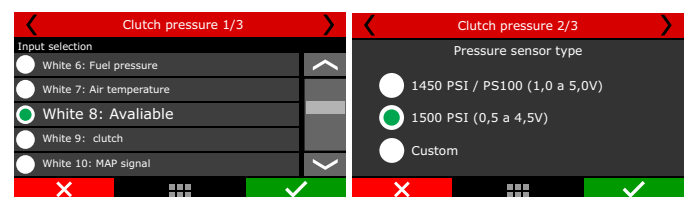

15.15 Ride Height

This function allows to read the front end height from the ground. The wheelie control is based on this input and you can find more on this at Chapter 20.9. Normally, a laser height sensor is used.



15.16 Pitch Rate

This function reads the rate at the front end pitches and is given by degrees per second.

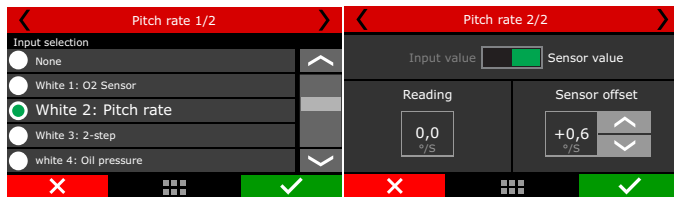

Through FTManager, all the sensors above can be configured in the "Sensors and Calibration" menu, then "Inputs".

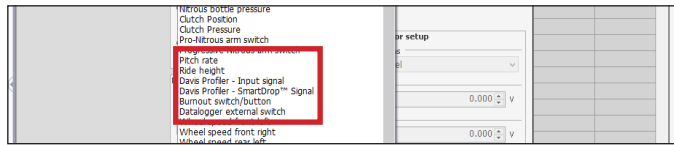

15.17 CAN communication

In this menu is possible to configure all the equipment connected to the CAN network. There are 2 different CAN protocols. Below is the compatibility of each protocol:

- FT CAN 1.0: GearController (until V2.17), BoostController, Racepak IQ3 and AIM Dashes;
- FT CAN 2.0: GearController (after V2.20) EGT-8 CAN; WB-O2 Nano and WB-O2 Slim;

CAN network supports up to 32 sensors of each product.

- This option allows stock ECU data to be received through CAN network.

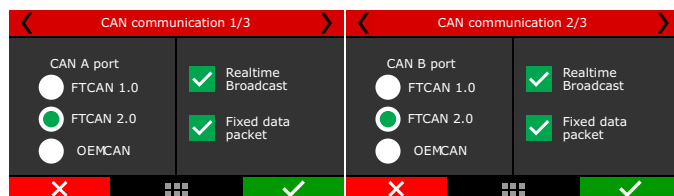
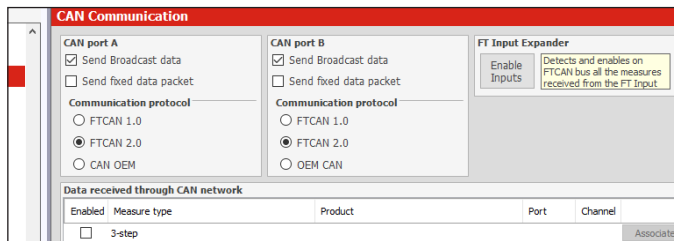

Realtime Broadcast: sends all data to a CAN network in real-time.

Fixed data packet: Creates data packages and makes it available on network, this option is used by equipment from other brands in the same CAN network.

- CAN OEM: This CAN port is intended for reading sensors vehicles that already have original CAN network from the factory.

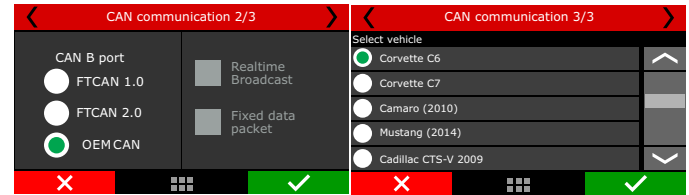

SwitchPanel Configuration

This is an external panel with 8 buttons that are totally configurable through FTManager via CAN Communication. Go to "Sensors and Calibration / CAN Communication / SwitchPanel and select a 4, 5or 8 version " click on the button you want to configure and select one of the many preset functions from the list.

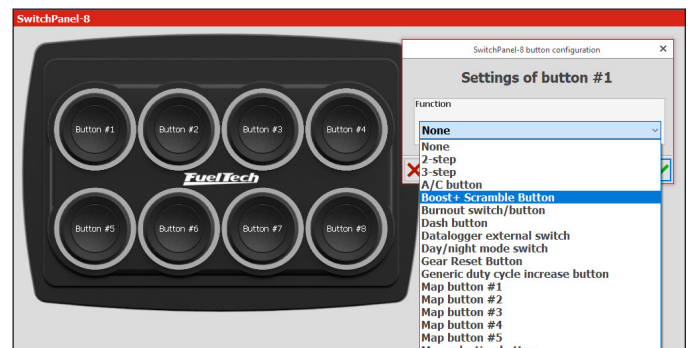

15.18 EGT

This menu allows to setup the EGT conditioners (ETM-1 or EGT CAN) and to perform the cylinder attribution. To do it, simply select the cylinder where the EGT is placed and what is the conditioner.

The attribution can be done using the CAN network with EGT CAN or using the white wires inputs with ETM-1.

To use EGT CAN, FT CAN 2.0 must be selected, then which model is being used (EGT A or B - for EGT-8, and the channel) or (EGT A, B, C and D - for EGT-4, and the channel).

NOTE
To configure the EGT-4, check the procedure in manual that came with the product.

EGT Settings

To configure EGT, access the menu "Sensors and Calibration / CAN communication/ EGT" an EGT image appears, click on the channels you want to configure and select from the list which will be sensor associated with this channel.

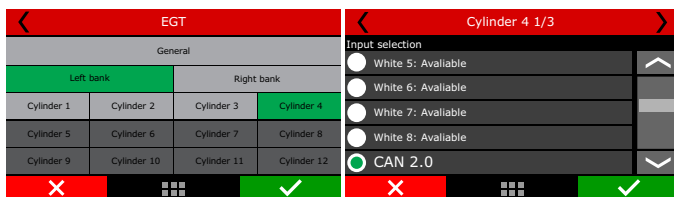
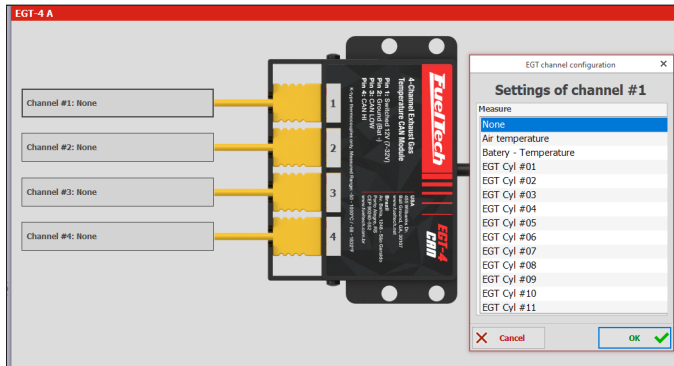
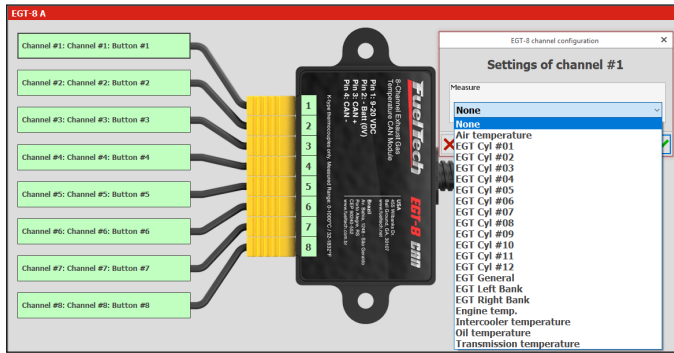

Acceleration direction: choose between Side of the ECU or perpendicular to the screen.

Acceleration signal: choose between normal or inverted.

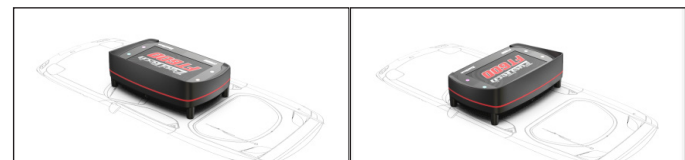
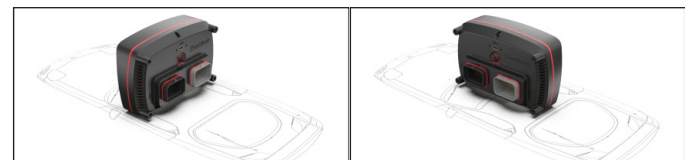
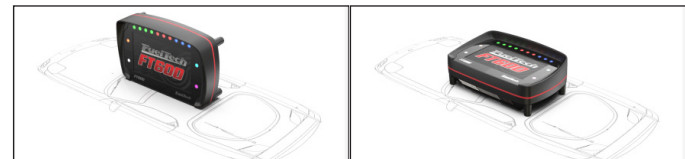
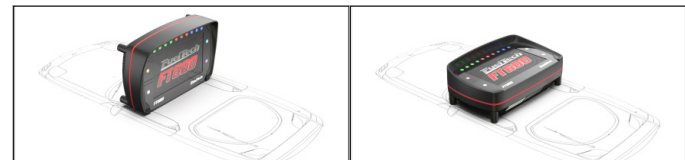
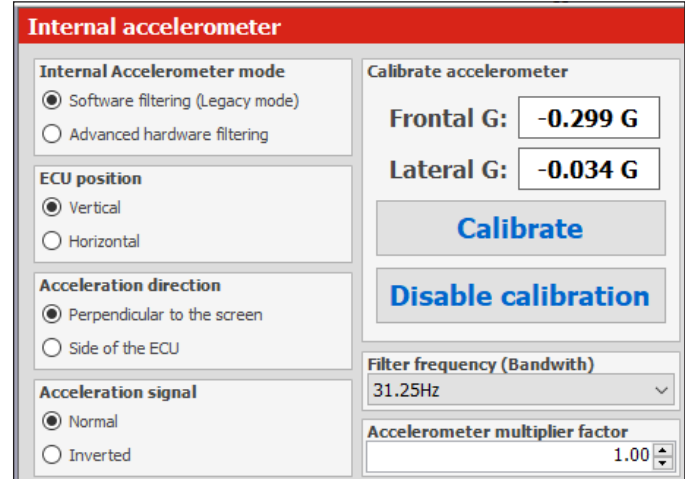

15.19 Wastegate Pressure

Setup the wastegate pressure sensor for use with the integrated BoostController. For more information check chapter 19.16 BoostController.

15.20 Internal accelerometer (FT550 /LITE and FT600)

After the FT installation, the accelerometer calibration is needed to avoid errors. It can be performed directly through the FT screen or through the PC Software FTManager.

FTManager 4.50 or newer Software versions allow the ECU to be positioned in any orientation in the car, this way it is necessary to configure the accelerometer axes.

ECU position: choose between vertical or horizontal.

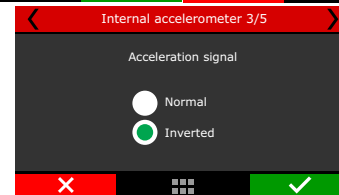
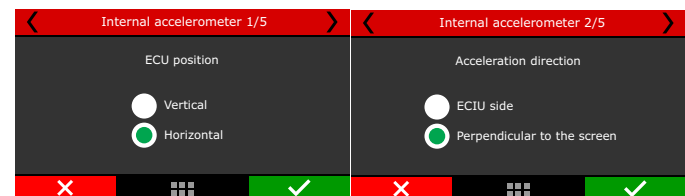

Accelerometer multiplier factor: it is typically 1.00, meaning that no multiplier factor will be used and that readings will be the original ones, from the accelerometer. If you notice that the calculated "Accel speed" from accelerometer is not matching a known vehicle speed reading (i.e. time slip showing 220mph on 1/4 mile but your datalogger Accel speed by accelerometer says 200mph) and you have already performed the accelerometer calibration and adjusted the filter frequency, then the multiplier factor must be changed from 1.00 to 1.10 in order to make Accel G readings increase by 10%, consequently increasing the calculated Accel speed also by 10%. This is very helpful when the active traction control is using the Accel speed as Reference speed and traction wheel speed (calculated by the driveshaft rpm) to calculate the wheel slip %, or when you have another external accelerometer device you are used to and want to make both match.

Calibration: The first step is to calibrate the accelerometer to compensate a tilted installation of the ECU, it must show 0G when vehicle is stopped and leveled.

Filter frequency: The filter is used to remove unwanted vibration so, if you have the ECU mounted on an OEM dash that is very isolated from chassis vibration you can probably use a higher filter frequency (62Hz or 125Hz) so it will improve reading of the small accelerometer changes. If you experience vehicle chassis vibration transferring and affecting the accelerometer readings, then a lower filter frequency (example as 15hz) is recommended.



IMPORTANT
A greater filter frequency will result in signal reading delay.

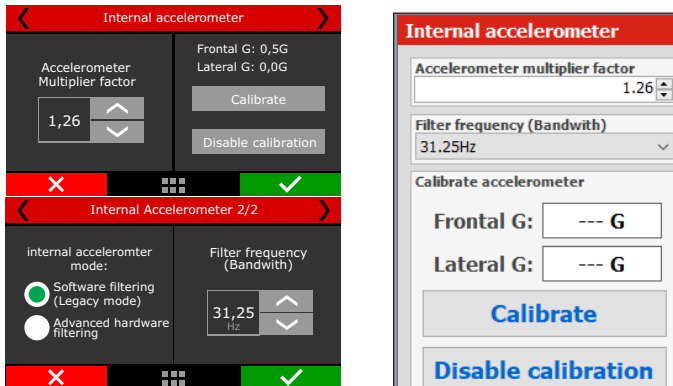

15.21 Brake Pressure

This function configures a sensor input for brake pressure control, helping the line lock function.

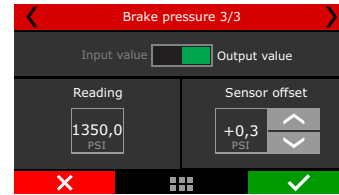
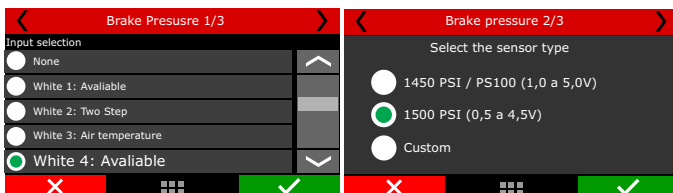

15.22 Front and rear shocks

This function allows to set the range for the sensor used on each wheel to measure suspension travel.

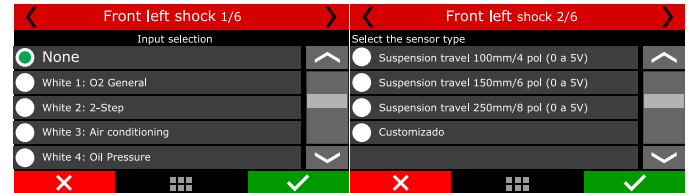

15.23 Flex Fuel

This function allows the use of a GM Flex Fuel sensor to measure the ethanol density that the gasoline has on the fuel line.

Discard reading during engine start: (where the drop on battery voltage may affect the sensors 12v power supply) and use values read before cranking.

Discard reading under high load: (where the high flow of fuel may affect the sensor readings) and use only below 2500rpm.

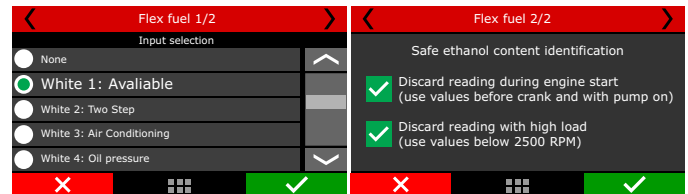

15.24 Back Pressure

This function allows to set up a pressure sensor to be used on the exhaust to measure back pressure.

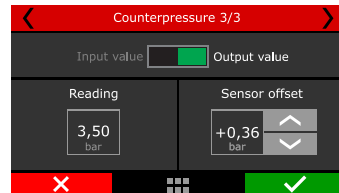
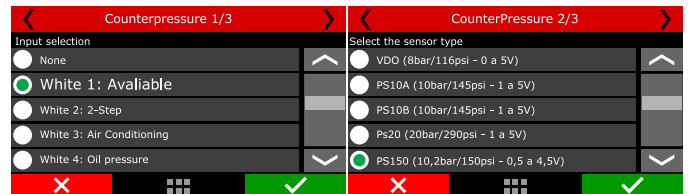

15.25 Oil pan pressure

Used to measure pressure inside the oil pan.

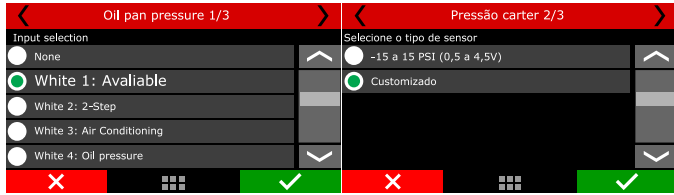

15.26 Transmission pressure

Monitors the pressure inside the transmission.

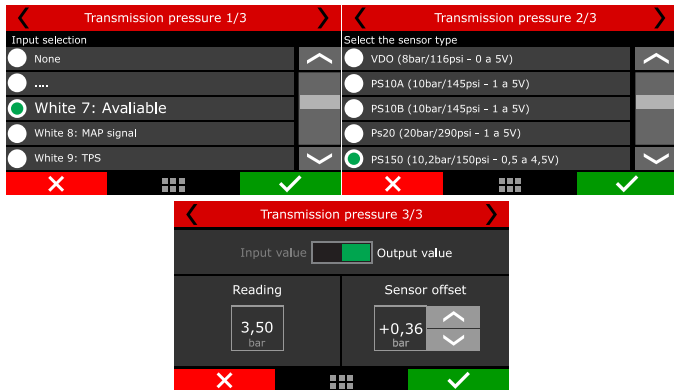

15.27 Transmission temperature

Allows to set a sensor to measure the oil temperature

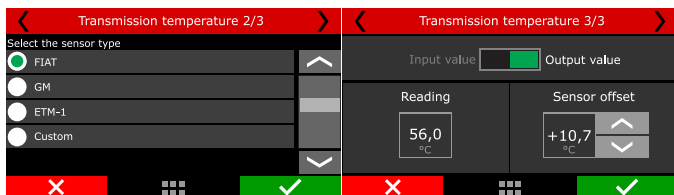

15.28 Torque converter pressure

This function allows to set up a pressure sensor to be used to measure torque converter pressure.



15.29 Intercooler temperature

Used to monitor intercooler temperature.

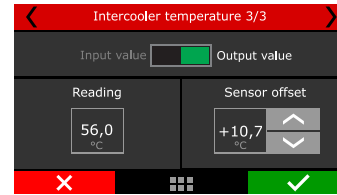
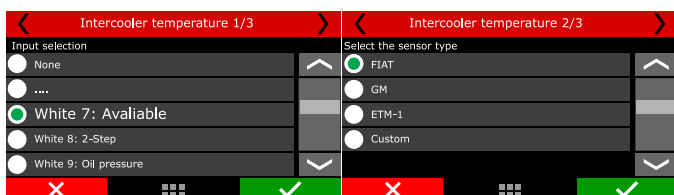

15.30 Front and rear tires temperature

Allows to monitor tire temperature using a laser sensor with either an ETM-1 wired into a white input or an EGT-8 via CAN.

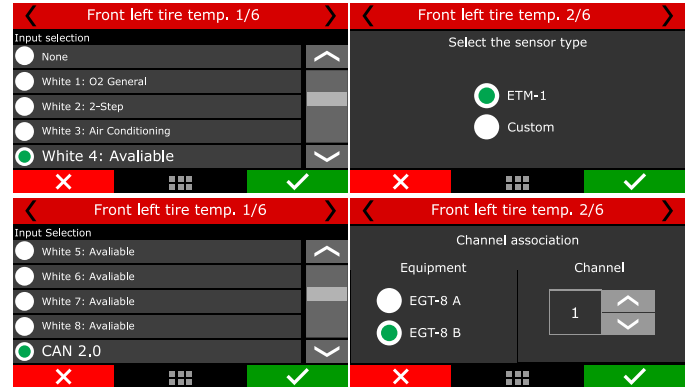

15.31 Track temperature

Allows to monitor track surface temperature using a laser sensor with either an ETM-1 wired into a white input or an EGT-8 via CAN.

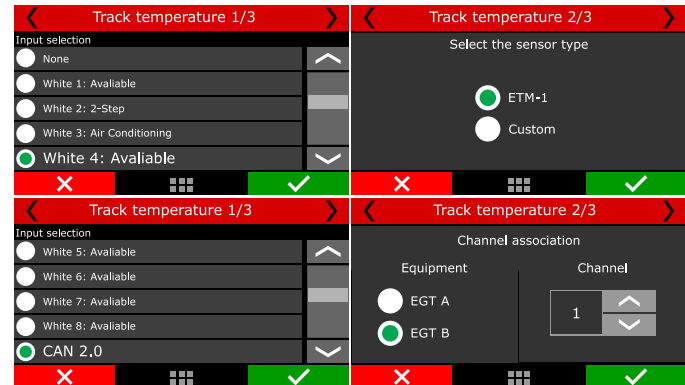

15.32 Engine Coolant pressure

This function it is possible to configure a sensor for monitor of the pressure to the engine cooling system. Set the sensor used if necessary, to adjust the offset.



15.33 Turning lights

Set an input for each turn signal (left and right) and whether it'll be activated at 0V or 12V.

Go to "Interface settings" and then "Side LEDs" to set up LEDs for each one of them, for more information refer to chapter 23.

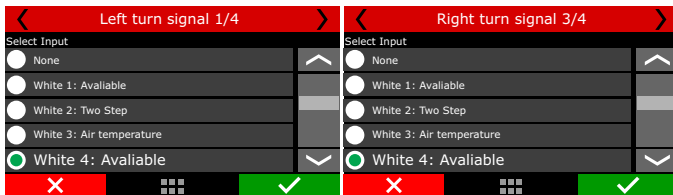

15.34 Low beam / High beam

Set one input for the low beacon and one for the high beacon, set whether the drive will be 0V or 12V.

Access the "Interface Configuration" menu then "LED Configuration" to adjust the high and low headlight drive indication LED. For more information, see chapter 23.

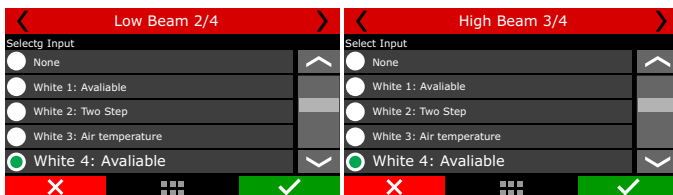

15.35 Turbocharger RPM

This feature reads the turbocharger compressor wheel speed. In order to use it a white wire input must be set as Turbocharger RPM. Set the internal divisor (provided by the manufacturer) and the number of blades of the compressor.

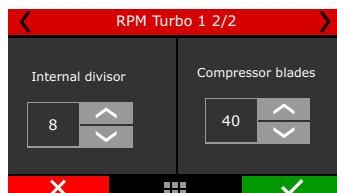

15.36 Fuel flow

Any sensor configured will be shown in the unit display and/or recorded in the datalog, to display fuel consumption, at least 1 sensor in the pressure line and 1 in the return line is needed. In the event of having 2 separated fuel feeds, like blower hat and intake runners, it is required to have 4 individual sensors to be able to measure fuel delivery per line.



NOTE

This feature requires a Hall effect fuel flow sensor, if a VR sensor is used, a signal converter to Hall effect is mandatory.

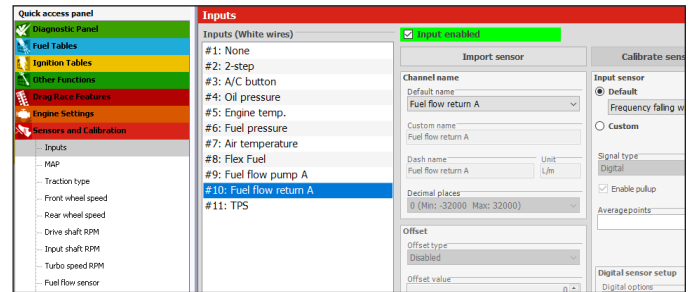

Fuel flow pump A: Pulses from the sensor to measure 10 US Gallon, so its possible to evaluate pump A fuel flow in the log.
Fuel flow pump B: Pulses from the sensor to measure 10 US Gallon, so its possible to evaluate pump B fuel flow in the log.
Fuel flow return A: Pulses from the sensor to measure 10 US Gallon, so its possible to evaluate fuel flow return A in the log.
Fuel flow return B: Pulses from the sensor to measure 10 US Gallon, so its possible to evaluate fuel flow return B in the log.

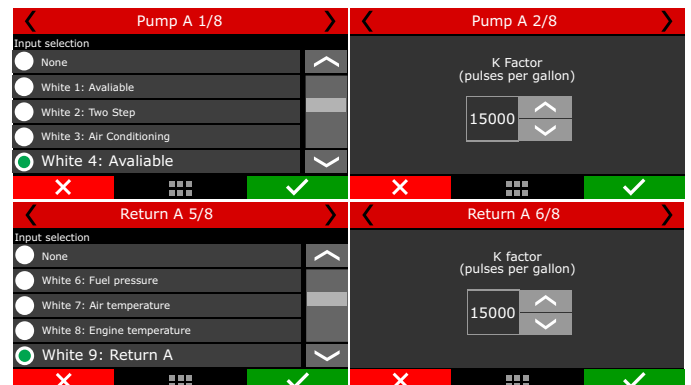
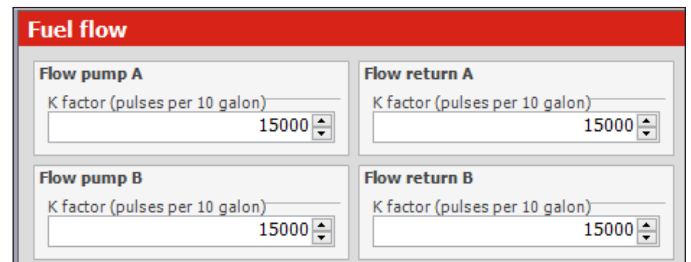

15.37 Flywheel RPM (Clutch basket)

Used primarily on motorcycles that have a gear ratio between the crankshaft and the input shaft/clutch basket.

To use this feature in a car, a 1:1 ratio must be used.

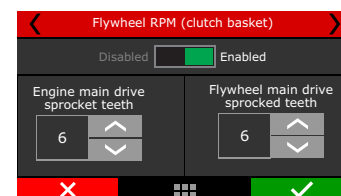

15.38 Automatic transmission range selector

This setting is required so the ECU can associate the inputs to the shifter position. The automatic transmission controller applies the parameters set in this tab to control the transmission.

There are four different settings: Digital, Analogic voltage level, CAN 2.0 Network and Duty cycle (PWM).

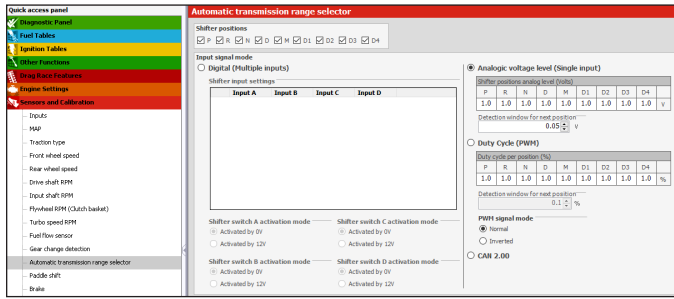

Digital

This option is the most complex to set up and requires some attention. The first step is to select which inputs correspond to each shifter position.

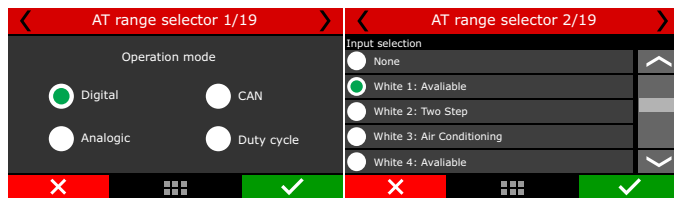

Shifter input settings: Select all available positions at the shifter, normally located at the dashboard or even at the shift lever itself.

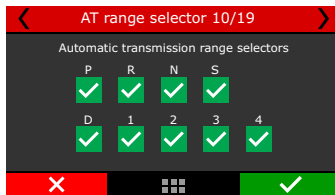

Input activation: This is directly related to the previous settings and assumes that if “activated at 0v” is selected, then all the options with a checked box will be activated at 0v. If “activated as 12v” is selected, then all checked boxes will be activated at 12v

Inputs position configuration: After checking the boxes to all shifter positions, select which inputs will be assigned to each position.

For example: For “P” position, A and C inputs will be activated. For “D” position, only input D will be activated and so on.

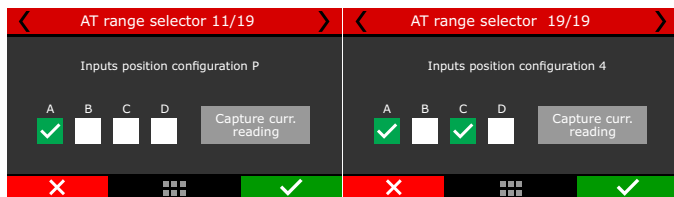

There is also a “Capture current reading” button that is very helpful during the setup. This process must be executed for all shifter positions.

For example: While the shifter is in position “P”, click in “Capture current reading” and the FT will automatically identify and set up the active input.

Analogic

This option must be used when there is only one input (white wire) dedicated for the ECU to identify the shifter position. The shifter sensor must be a potentiometer that will vary the voltage and therefore send different values for the ECU according to each position. Each voltage must be set up in the ECU, as well as each detection window between the positions.

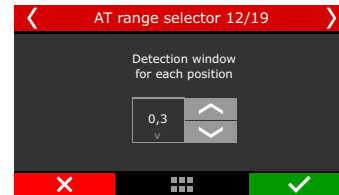
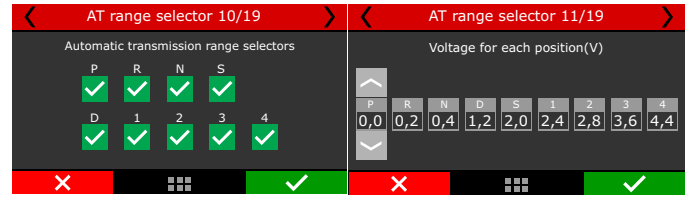

CAN 2.0 Network

This option allows the use of a SwitchPanel to select gears. After the positions are selected, you must set a SwitchPanel button to activate each one.

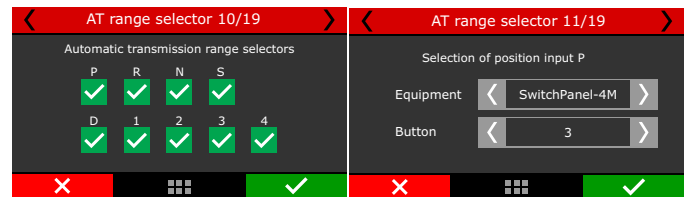

Duty cycle

This option can be used when there is only one input (white wire) identifying the shifter positions through a PWM percentage. To set this up, it's necessary to set up the input, define the shifter positions, adjust the Duty cycle percentage for each position and set the detection window around each percent.

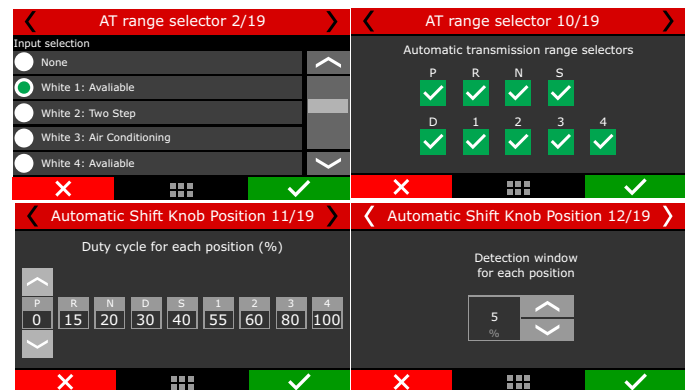

15.39 Paddle Shift

This option allows the driver to perform gear shifts by paddle shifters. You must set up an input for upshifts and another for downshifts.

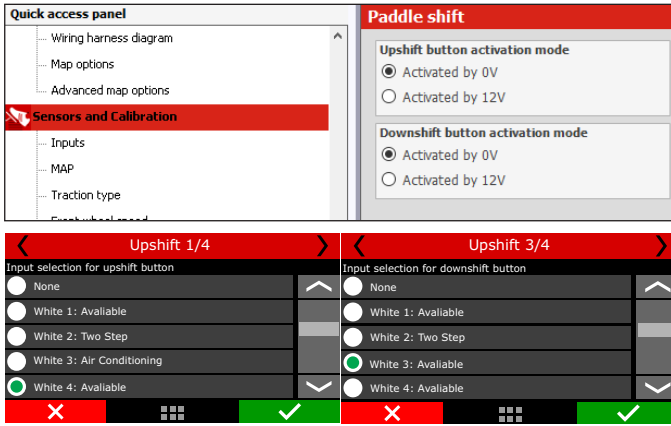

For vehicles that doesn't have paddle shifters, the gear shifts can be operated through a SwitchPanel. Just select the "CAN 2.0" option and assign which buttons will be responsible for up shifting and downshifting.

15.40 Brake

This function is related to the Lockup system. A sensor can be used to read the line pressure and adjust a ON and OFF range or just a brake switch to activate/deactivate the Lockup.

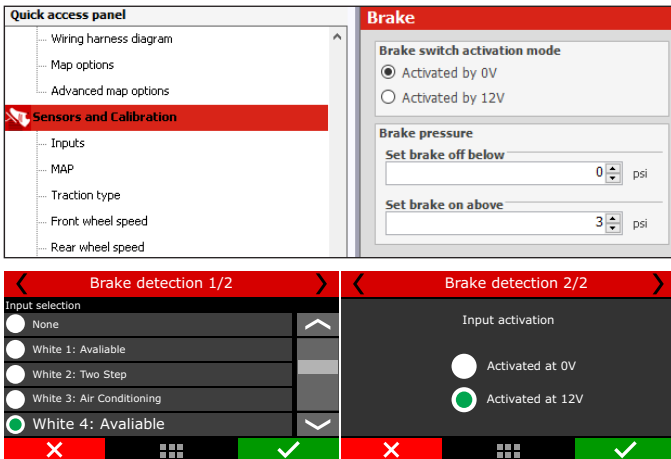

15.41 Multifunction button

Allows the use of a single input to act as staging control, boost+ (scramble) and line lock button, according to set conditions:

1st condition: When on 2-step/Transbrake it acts as Staging Control(bump box)

2nd condition: After a validated launch it becomes the Boost+(scramble) button

3rd condition: When the speed and driveshaft reading is 0, it turns into a Line Lock button



15.42 Battery temperature

This function configures a sensor to monitor the temperature of the battery.

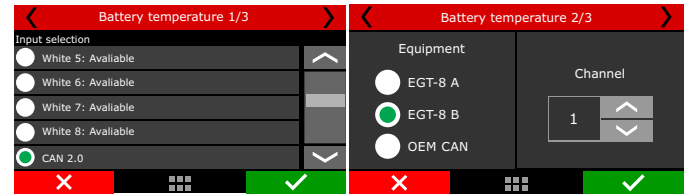

15.43 Compressed air pressure

This function monitors the pressure in a compressed air tank, very useful for vehicles equipped with pneumatic gearboxes.

15.44 Fuel Consumption Control

This function, allows you to calculate the vehicle's fuel consumption. The flow calculated here is used to define the car's range and consumption during use.

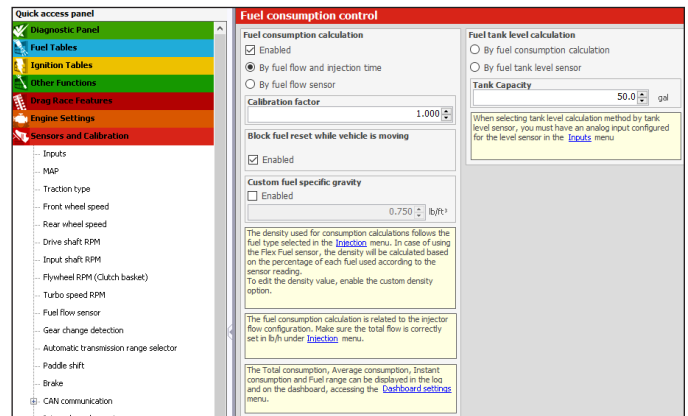

Configure the vehicle's fuel tank volume.

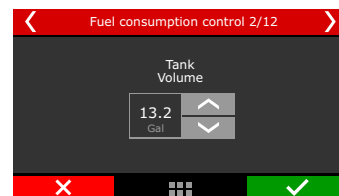

Then select what will be the method of calculating consumption.

By fuel flow and injection time: in this option the calculation will be based on the injection time and flow of the injectors.

For a more accurate calculation it is necessary that the flow of the injectors is correctly configured in the map.

To check this, in FTManager software, go to "Engine Settings/Fuel Injection" and "Primary total flow".

By fuel flow sensor: this can be used when the vehicle is equipped with a specific sensor for reading the fuel flow.

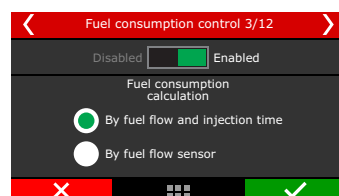

Fuel Density: The density varies depending on the type of fuel in the tank. This value is automatically set when you choose the type of fuel in the map. When using a Flex Fuel sensor this setting is changed automatically depending on its reading.

Correction Factor: this factor adjusts possible differences between the read value and the actual value.



Select the method of calculating the tank level.

By fuel tank level sensor: when the car has equipped with a fuel level sender unit.

By fuel consumption calculation: uses the volume of the tank and calculates consumption through injection time and injector flow.

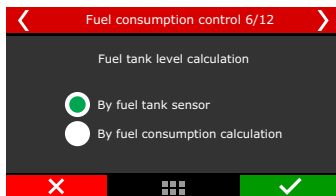

When the vehicle is equipped with a fuel level sensor, it's necessary to define an input to read it. Also define the type of sensor used and if there is any reading offset, it can be adjusted.

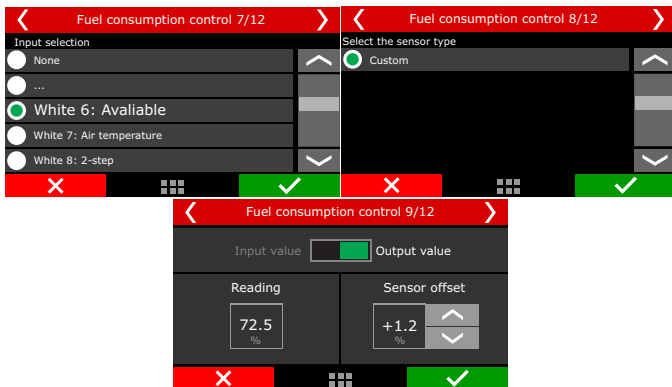

The last step is to set up an input for a fuel consumption reset button. This button has the same function as a factory car that can reset the dashboard values to obtain a new average fuel consumption.

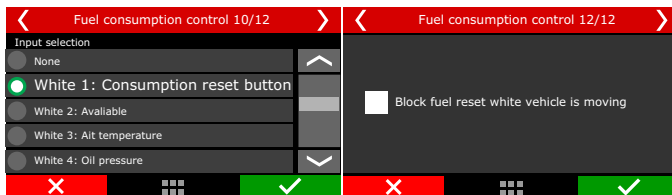

16. Starting the engine for the first time

This chapter shows final steps before the engine first start and guides the user through checking and calibrating all the sensors and actuators of the motor.

16.1 First engine start

Try not to stress the starter motor by cranking too long on the make the first start. Check if the fuel pump is turned on and if there is fuel pressure on the line. Check if the FT reads the correct RPM in its dashboard and make sure there's spark on the spark plugs (unplug the spark plug wires and install a spark plug on it to check for spark).

On engines fueled with ethanol or methanol, use a squirt of gasoline into the throttle body to make the first start smooth.

When the engine starts, keep it at a fast idle and double check oil pressure and the coil and igniter temperature.

Check if the RPM is being correctly shown on the ECU display (if possible, compare to an external tachometer) and if throttle variations coincide with TPS and vacuum readings.

16.2 Ignition calibration

Once the engine has started, before any kind of test or tune, the ignition calibration must be performed. This calibration is very important to make sure the timing the ECU reads is really correct with the engine. This function locks the timing to 20° (or 0°) on any RPM, this means, if the engine starts but has no idle, you can rev it up and keep it in something around 2000rpm to perform the calibration. Avoid RPM variations as this causes variations on the timing light readings.



The access to this function is given by the "Ignition" button in the main FTManager menu or the "Calibrate ignition" in the touchscreen "Sensors and Calibration" menu

Ignition calibration with distributor: On the engines originally equipped with distributor, there's a TDC mark for cylinder #1. Point the timing light and turn the distributor until the timing light reads 20°. Lock the distributor then press "OK" button on the ECU. Ignition calibration is finished

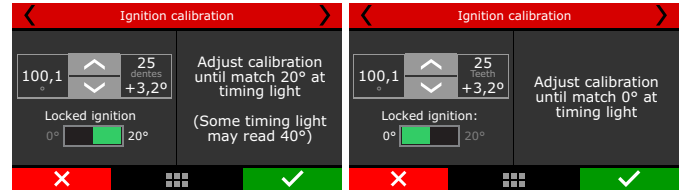
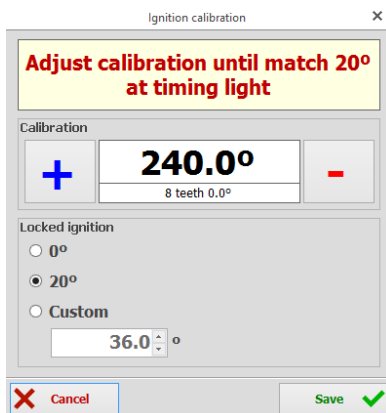

Ignition calibration with crank trigger: Cars originally equipped with crank triggers, usually do not have the TDC mark. This mark then should be done by stopping the engine on cylinder #1 TDC of compression using a dial-comparator. It is very important to be precise when making this timing mark; the slightest error will ultimately affect ignition timing on the engine

In these systems, usually the ignition is controlled on wasted spark, with one spark on the combustion stroke and one on the exhaust stroke. As the timing light reads both sparks, it usually shows 40° BTDC of timing, but the actual timing is 20° BTDC.

As it is not possible to turn the crank trigger as we do on distributor systems, the ignition calibration screen has a compensation that must be changed until the timing light shows 20° BTDC (or 40°, according to the timing light). Let's say you read a timing of 24° BTDC, a compensation of -4° is needed to read 20° BTDC on the crankshaft TDC mark. When the timing light is reading double the real timing (wasted spark), if the timing on the timing light is 46°, the compensation that must be set is -3°, instead of -6°.

To check if your timing light is reading twice the real timing, advance 5° and check the timing on the engine again. If the timing has advanced 10°, the timing light is reading double the real timing.

17. Fuel tables adjust

17.1 Main fuel table

Editing mode for main fuel table is set as 2D basic mode by default, but it is possible to switch to advanced 3D mode. To change parameter, in the FTManager, go to "Advanced map options" in the "Engine settings" menu.

On FTManager, it is possible to edit the map cell ranges of MAP/TPS, RPM, etc., making it possible to increase the detail level on the maps where a fine tuning is needed. To do it, simply click on "Edit axis" on FTManager tool bar.



Basic Mode - 2D table

In the basic mode, the engine is tuned according to the MAP sensor or TPS. By default, the main fuel table by MAP is from -14.5psi up to the desired pressure.

When the main fuel table is by TPS, the table is from 0 to 100% in 10% steps.

Through FTManager, it is possible to use up to 32 cells, which will allow to have a better map and a fine tuning.

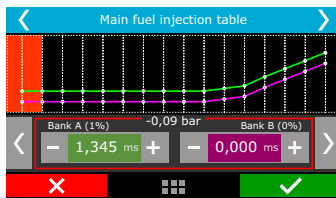
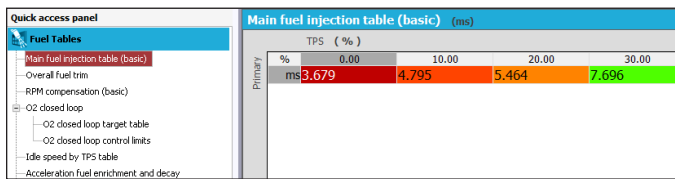

Advanced Mode - 3D table

In the advanced mode, the main fuel table is a 3D table, where the injection time is calculated according to the MAP sensor (or TPS) and engine RPM. As well as the basic mode, the MAP range is from -14.5psi up to the desired pressure. When the main fuel table is by TPS, the table is from 0 to 100% in 10% steps.

The default RPM steps are 200rpm until 3000rpm, and above this rpm the steps are in 500rpm. The MAP, TPS or RPM steps can be edited via FTManager.

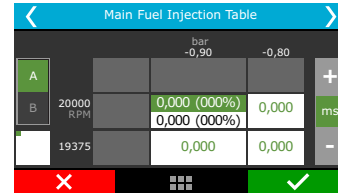
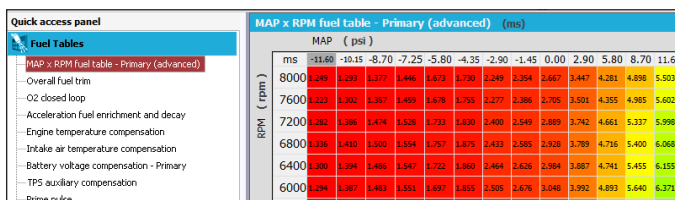

17.2 Overall fuel trim

The overall fuel trim recalculates and replaces all values of the main fuel table according to the percentage configured. This functions can be accessed through "Fuel tables" menu.

When using individual banks, the trim will be available to each bank.

This compensation applies a percentage that can add or remove fuel from the main table (basic or advanced mode). For example, if in a certain cell the injection time is 2.000ms, representing 50% of injector opening at maximum rpm, and you apply 10% compensation, the result will be 2.100ms, representing 55% of injector opening, if the dead time is 1.000ms.

In all compensations the dead time must be discounted, so the value can be related to amount of fuel, instead of pulse width purely.

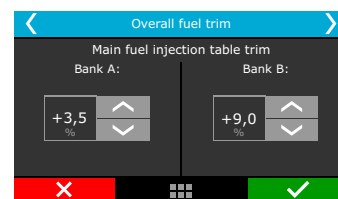
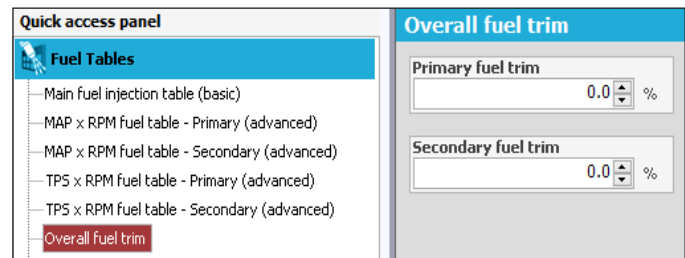

17.3 RPM compensation

This option is exclusive to the basic mode. The RPM compensation is a percentage compensation applied to the main fuel table. The calculation is automatically done considering the engine RPM and all the other compensations. This way, a 3D table is not necessary, which despite being more accurate, is harder then the basic mode and very often doesn't show a better result.

With the RPM compensation is possible to have a good tune in any engine type, either a stock engine, race engine or with a variable camshaft (Honda VTEC, Toyota WT-i, BMW Vanos, etc).

Every engine has a specific fuel consumption peak around the maximum torque rpm, so in the region additive compensation between 5 and 15% must be applied. In a stock engine the maximum torque

is normally between 2000rpm and 4500rpm, but to know exactly the rpm a dynamometer is required. Anyway, this compensation will be performed, because, to keep a constant AFR, more fuel will be needed at the maximum torque rpm.

With the main fuel table and the RPM compensation, the ECU generates internally a injection time vs load vs RPM table.

Quick access panel		RPM compensation (basic) (%)						
Fuel Tables		RPM (rpm)						
<ul style="list-style-type: none"> Main fuel injection table (basic) Overall fuel trim RPM compensation (basic) O2 closed loop Acceleration fuel enrichment and decay 		rpm	400	600	800	1000	1200	1400
		%	0.0	0.0	0.0	0.0	0.0	0.0

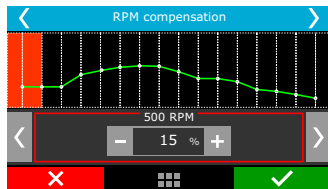

IMPORTANT
It is very important to check data continuity, avoiding incoherent values that may produce abrupt changes on the RPM graphic.

17.4 O2 Closed Loop

O2 closed loop reads O2 sensor and adds or removes fuel from the main fuel table in order to reach the O2 target set up.

Quick access panel		O2 closed loop config	
<ul style="list-style-type: none"> Main Fuel injection table Overall fuel trim RPM compensation O2 closed loop 		Minimum engine temperature: 68 °F Smoothing for low load: 12 Off below: 400 RPM Off above: 8000 RPM TPS idle target: 5.778 AFR	Behavior during acceleration fuel enrichment: Turn off closed loop Behavior duration: 0.150 s Comportamento durante a troca de marcha: Altrado O2 closed loop on boost, 3-step and 3-step: Disabled Average value protection: Enabled

Low load smoothness is the speed control for low load situations like idle speed, where the O2 closed loop must reduce the compensation for O2 variations.

Engine temperature for control start is a temperature limit below which the O2 closed loop stays disabled and assumes the open loop fuel tables.

Sets RPM limits for the control to be automatically enabled or disabled. In vehicles where the O2 sensor is installed at the end of the exhaust usually a stable reading is only obtained after a certain RPM, in this case , it is recommended to disable the closed loop when RPM is lower than the optimal point.

The higher RPM limit is used to disable the control above a certain RPM. Forcing the ECU to go back into open loop operation.

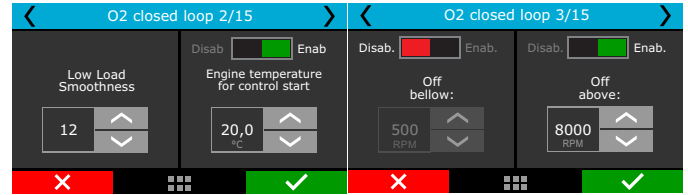

During acceleration fuel enrichment it is possible to choose to turn off the closed loop or to freeze closed loop compensation during some time. The closed loop will return to its target between 300 and 500ms after the acceleration fuel enrichment is over.

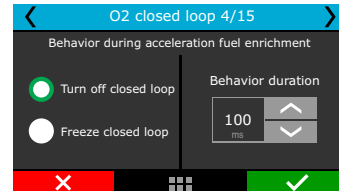

Adjust the closed loop strategy during and after a power reduction cut used for gear shifting. It allows to disable the closed loop or freeze the closed loop target for a period of time after the cut starts.

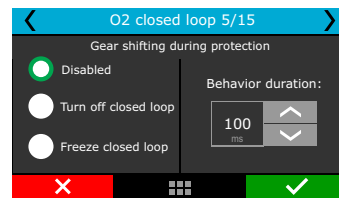

Select the O2 sensors that will be used to calculate the AFR average value for closed loop control.

This is a safety feature for O2 reading. When the protection is enabled, if the reading of one O2 sensor is above 16.1AFR gas or 7.0AFR alcohol, the value is excluded of the O2 closed loop control average calculation to prevent a misreading of a damaged sensor.

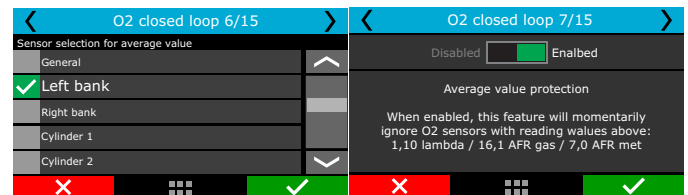

This is the lambda target map that the Closed loop control will use as a base to tune your map.

This table has up to 256 points (up to 16 columns and 16 rows) and relates engine speed (RPM) with throttle position (TPS) or engine speed with manifold absolute pressure (MAP).

It is also possible to block the O2 closed loop under or above some RPM limits. The "Lock below" parameter is used, i.e., on engines where the O2 sensor is installed too close to the end of the exhaust, reading free air below a certain RPM. The "Lock above" parameter is a limit to disable the O2 closed loop and return to the open loop maps.

Next, is a 3D table of O2 closed loop targets versus RPM and MAP. It has up to 16x16 cells that can be edited through the PC Software.

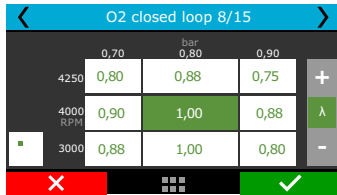
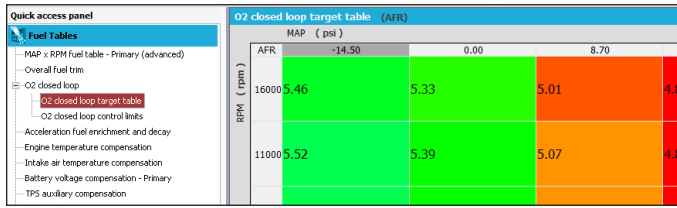

When the option of a single target for 2-step, 3-step, burnout mode, Anti-lag, Pops & Bangs, Engine brake is activated, the closed loop will follow only that number, despite of RPM, boost or TPS reading.

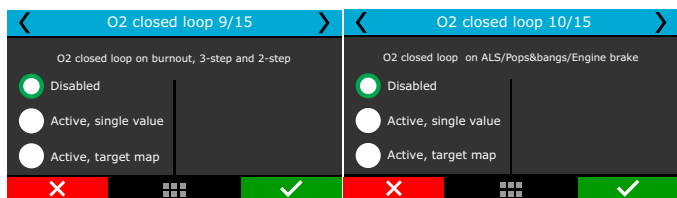

The next screen is only shown when the idle is TPS based. Set a target for idle condition (TPS=0%).

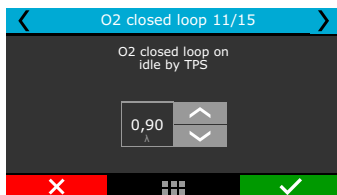

O2 closed loop control limits is a 16 points (8 columns and 2 lines) table, totally editable, by TPS or MAP, which defines the actuation limits of O2 closed loop, avoiding the control to remove or add too much fuel in certain situations.

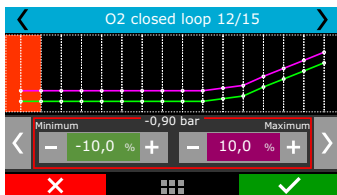

Auxiliary O2 closed loop:

Aux by time (2-step):

This feature allows the creation of a 16 points time based O2 target table after the 2-step deactivation, which will overwrite the main O2 target table during the time setup on this auxiliary table. To trigger the 2-step, TPS must be above 50% or RPM must hit the 2-step rev limiter.

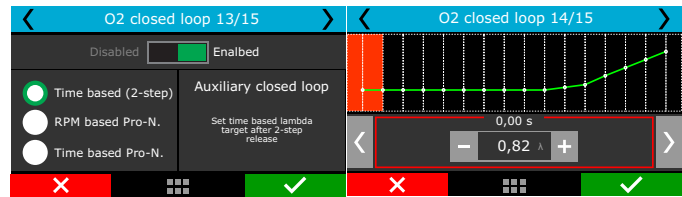

Aux Pro-Nitrous by RPM:

This feature allows the creation of a 16 points RPM based O2 target table to each Pro-Nitrous stage, which will overwrite the main O2 target table while the auxiliary control is on. This feature is only enabled when all Pro-Nitrous requirements are fulfilled.

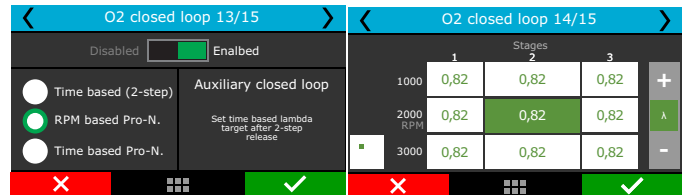

Aux Pro-Nitrous by time:

This feature is a 16 points time based O2 target table to each Pro-Nitrous stage, which will overwrite the main O2 target table while the auxiliary control is on. This feature is only enabled when all Pro-Nitrous requirements are fulfilled.

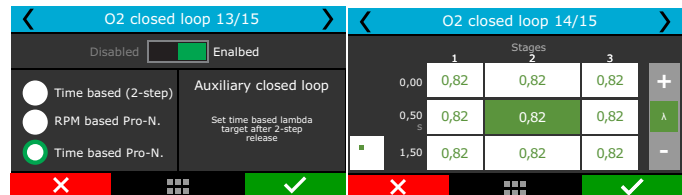

17.5 Idle speed by TPS table

This menu is only available when the idle speed is set up by TPS. The injection time is adjusted according to the engine RPM.

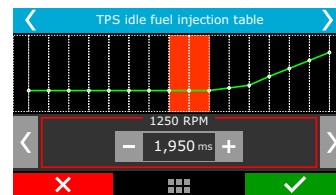
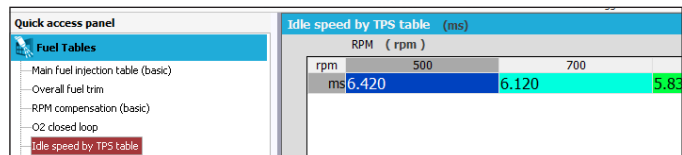

17.6 Acceleration fuel enrichment and decay

Acceleration enrichment is a fuel increase when the throttle is suddenly opened.

Max fuel on pump: value added to the actual injection time when a quick throttle variation is detected. There are two RPM and injection time parameters to be set. With them, the FT creates an acceleration fuel table that interpolates the values between these two positions. TPS/MAP variation for maximum fuel pump shot: This configures the MAP or TPS variation for which the max fuel pump will be used. Engines equipped with small throttles usually need a higher TPS

variation to need max fuel pump. In this case, use higher TPS values on this parameter (70-90%). For big diameter throttle bodies, a small TPS variation is enough to demand max fuel pump (around 15%). The TPS or MAP selection is done in the Engine Setup menu. If the TPS is not present, MAP must be selected.

Accel fuel pump reduction above TPS 50%: due to reduced need of fuel when the acceleration fuel pump occurs with the throttle already opened above 50%, this parameter reduces the max fuel pump on this condition. By standard, the ECU reduces 50% of the max pump when it occurs above 50% of TPS.

Cold engine fuel pump enrichment: this is a simple increase on the max fuel pump value when the engine is cold, especially necessary on the first few minutes of engine operation.

Fuel decay on max pump: this is the injection time that will be subtracted from the actual injection time during a sudden throttle closure. With this, in a fast throttle closing, is possible to remove fuel and have a more stable AFR during deceleration.

Minimum variation of TPS/MAP for pump shot: A minimum percentage of variation can be set so the pump shot only starts to be applied above it.

Minimum variation of TPS/MAP for decay: A minimum percentage of variation can be set so the decay only starts to be applied above it.

Decay max pulse: that's the injection time to be subtracted from the actual injection time in the event of a sudden throttle closure.

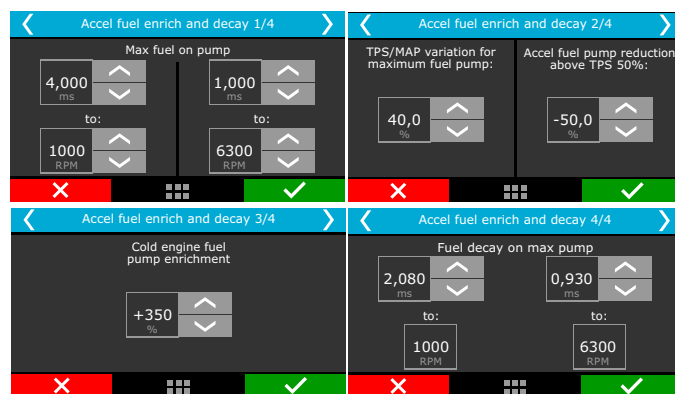
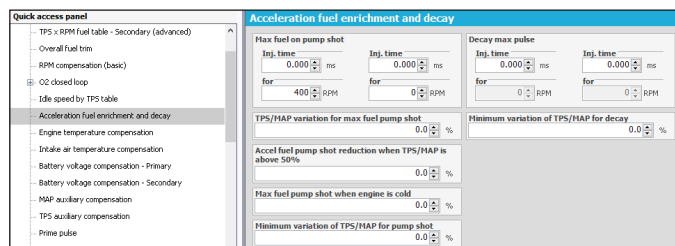

17.7 Engine temperature compensation

Engine temperature greatly influences the amount of fuel requested by engine, especially in cars run with ethanol and methanol, when it is possible to operate a cold engine as if it had already reached normal temperatures.

This compensation is applied based on the engine temperature sensor, which, in water-cooled cars, must be at the cylinder head reading the water temperature, and in air-cooled engines, must be reading the oil temperature.

Compensations based on engine temperature are only available when the sensor is connected to the injection system.

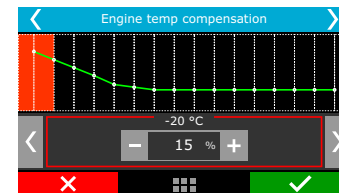
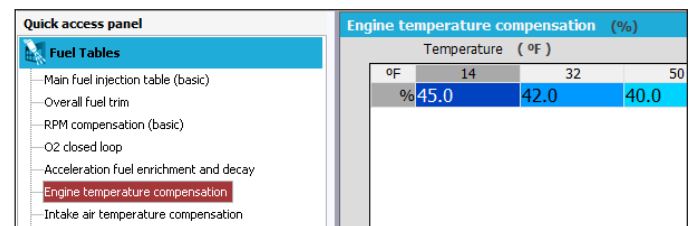

17.8 Intake air temperature compensation

This compensation is applied based on the air temperature sensor placed in the intake manifold, and it is only available when the sensor is connected to the injection system.

This compensation mode is used to automatically adapt the injection to different temperatures of the air taken by the engine. In turbocharged engines, it is of great importance, because when the system is pressurized, the temperature rises immediately to very high numbers.

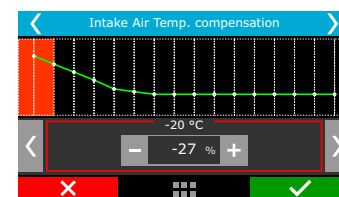
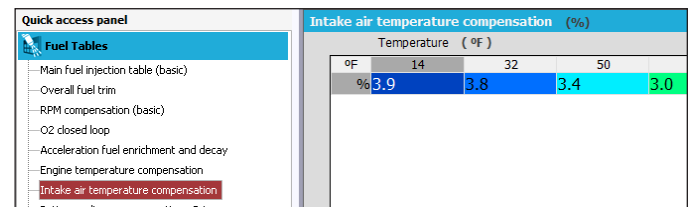

17.9 Battery voltage compensation

With lower battery voltages the injectors take a longer time to open and to close. This table is used to compensate this variation.

Fuel injectors with a high flow rate usually operate with minimum injection time at idle speed and are the ones most affected by a battery voltage drop.

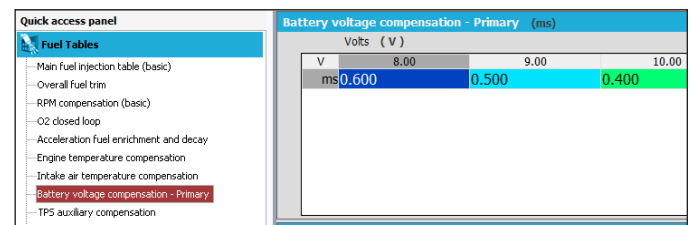

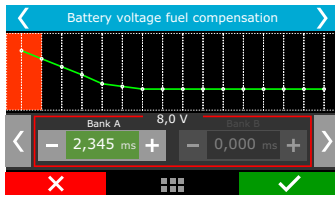

17.10 MAP / TPS compensation

This table changes according to the main map configuration (MAP or TPS). When the main fuel table is setup by MAP, this table is a compensation by TPS. When the main fuel table is setup by TPS, this compensation is by MAP.

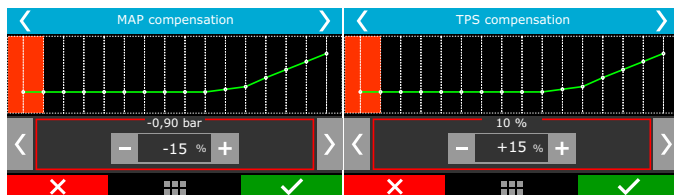
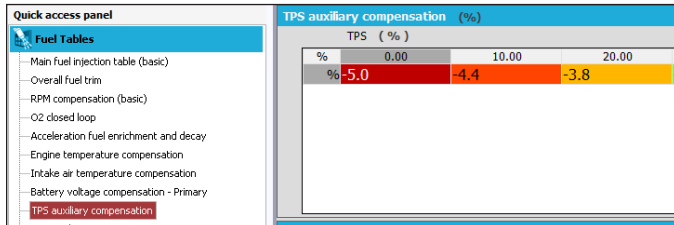

17.11 Prime pulse

This feature improves the engine start by injecting fuel when any crank trigger tooth is detected, just like OEM ECUs. Usually this table uses injection times higher than the "engine start" parameter injection times.

Select which fuel bank you want to use for prime pulse and setup its table by engine temperature.

The injection time is related to engine temperature. The colder the engine, the bigger the injection time.

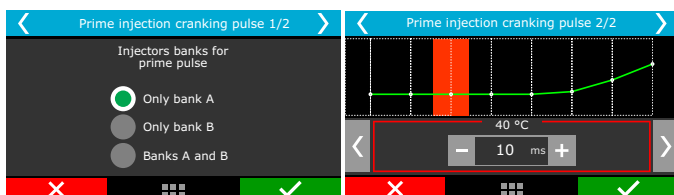
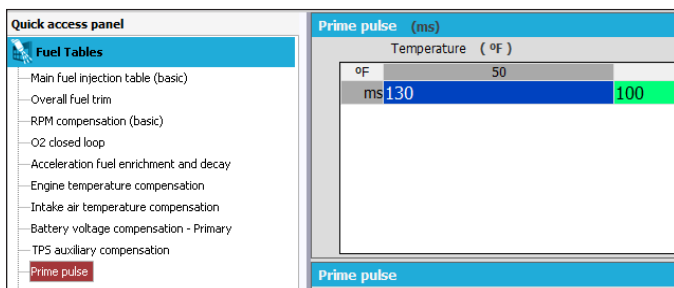

17.12 Engine start

This function is essential when starting the engine, as it needs a greater injection pulse to initiate its operation, especially if the vehicle runs on ethanol or methanol.

Whenever the RPM drops below 400rpm, the ECU applies start injection pulses in addition to the idle speed value. This excess of fuel prevents the engine from failing involuntarily, making it return to idle speed. Be careful not to exaggerate on injection time, as it may cause the engine to stall/flood easily.

The engine must always be turned off through the injection system. Otherwise, if RPM drops below 400rpm and injection is turned on, the system injects fuel that will not be burned and, therefore, will be accumulated on the cylinder.

If the engine temperature sensor has not been installed, only the value from start injection with cold engine is considered.

The bank B option will be only available if enabled on "Injection" menu on "Engine Settings"

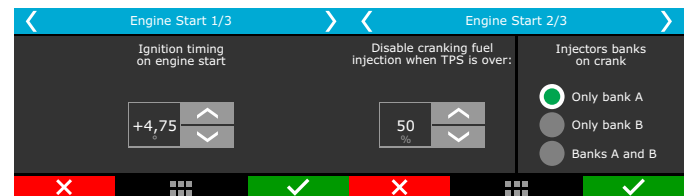
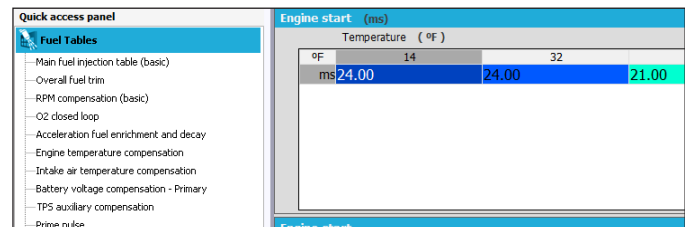

17.13 Post-start enrichment

This configuration is a table that relates engine temperature with time in seconds. This parameter helps stabilizing engine RPM just after start, improving the idle control especially under low temperature conditions.

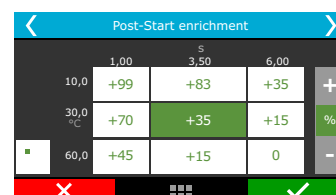
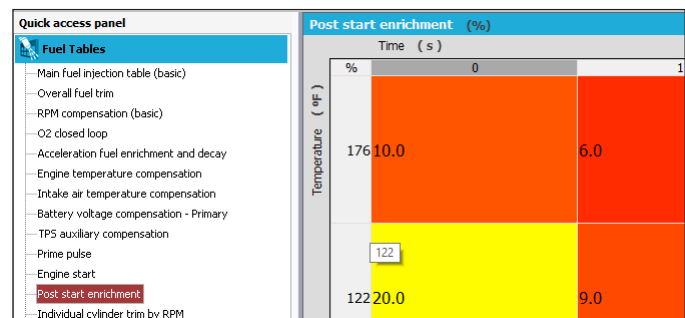

17.14 Individual cylinder trim

Set a compensation to each injectors output on a table that relates engine RPM with individual cylinder trim compensation.

To use this compensation as a cylinder trim, the injectors have to be wired with one output per injector.

This compensation usually brings minor power gains when correctly used, so, the use of one O2 sensor per cylinder is highly recommended

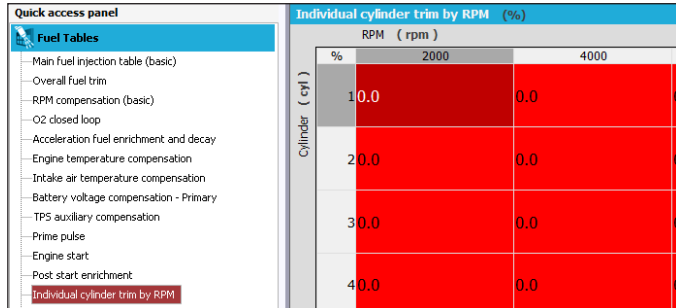
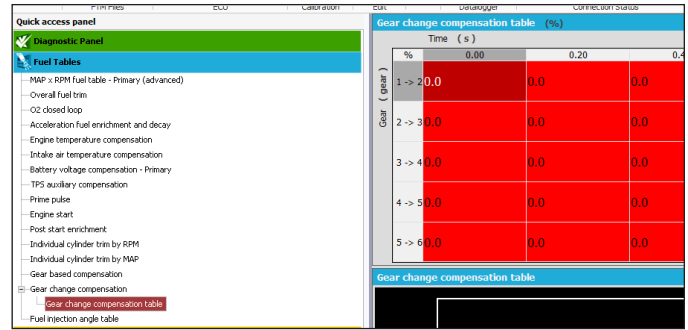

17.17 Gear shift fuel enrichment

This function enables fuel compensation when a gear shift is detected, that allows building a time based enrichment table.

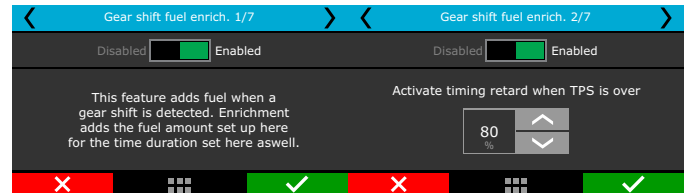
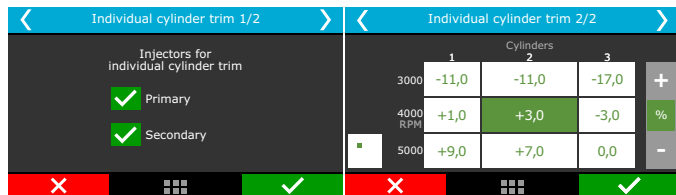
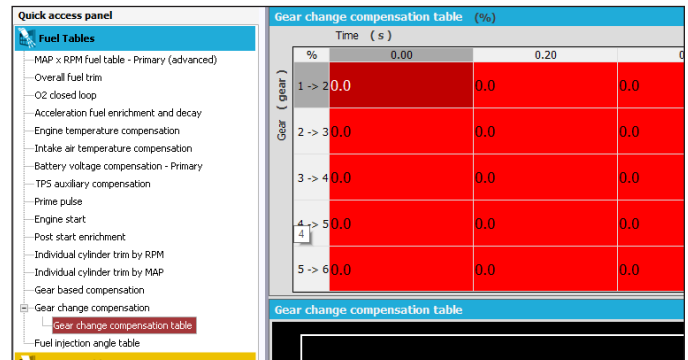

17.15 Rotor compensation

Available only when controlling rotary engines, this is an individual rotor fuel trim. This compensation usually brings minor power gains when correctly used, so, the use of one O2 sensor per rotor is highly recommended.

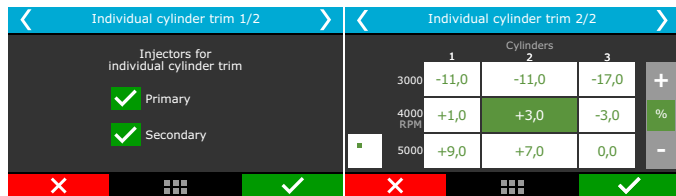
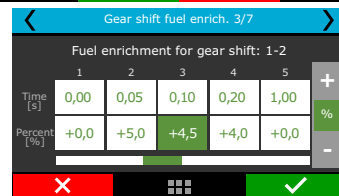
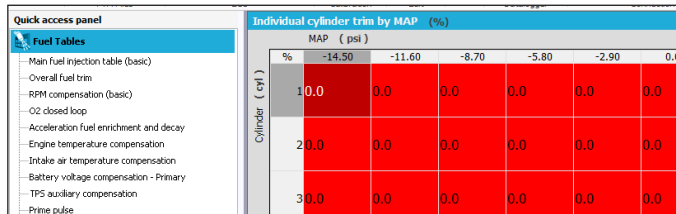

17.18 Fuel injection phase angle table

This table changes the moment, during the engine cycle, where the injectors open or close and is only available when the fuel injection is being controlled in sequential mode. The injection phase angle is the distance, in degrees BTDC from the ignition TDC (0°) until the moment the injector opens or closes (according to what is selected).

17.16 Gear based compensation

This option allows having a RPM based fuel compensation for each gear.

To enable this option, gear change detection must be enabled. It is possible to set up to 6 compensation tables (6 gears).

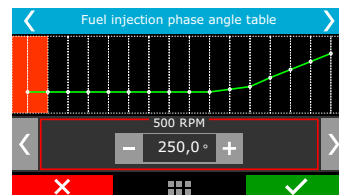
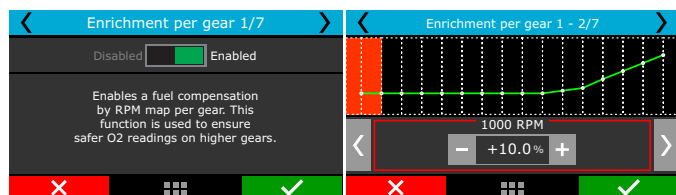
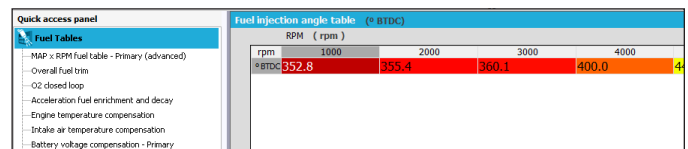

18. Ignition tables adjust

All timing tables can advance or retard timing. When a base map is generated, all tables are filled with standard values, so, if you want to use just the main timing table, you must zero fill all compensations manually.

18.1 Main ignition table

The editing mode of this table is, by default, this table is displayed in a 2D format. It is possible to change to a 3D table using the FTManager software.

Through the software is also possible to edit the range interval of MAP, TPS and engine RPM on the maps. This makes possible to increase the detail level on specific ranges where a fine tuning is needed.

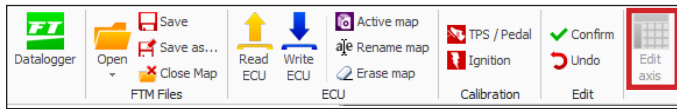

Basic mode 2D table

In this mode, the main ignition table is a 2D map that relates RPM and timing from 400rpm to the max RPM.

Using an analogy, if you want an initial timing of 15° and final of 32° (as you do on a distributor), you must enter 15° at 600rpm and 32° at the maximum rpm, 8600rpm for example. The timing between maximum and minimum RPM are interpolation of initial and final timing. If you want to run a fixed timing, all cells must be filled with the same timing.

Remember that the timing applied will only be the same as the main table if all the compensations are zero.

The rpm breakpoints can be changed up to 32 cells, allowing a fine tuning.

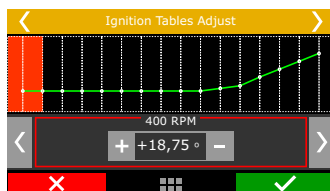
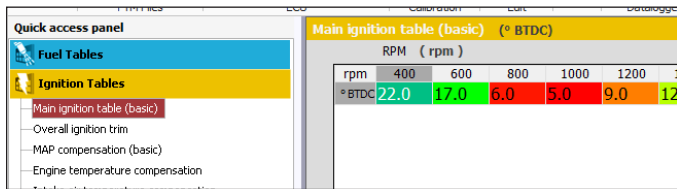

Advanced mode 3D table

In this mode, the main ignition table is a 3D map that relates RPM x MAP x ignition timing. As well as the basic mode, the MAP range is from -14.5psi up to desired pressure. When the main timing table is by TPS, the table is from 0 to 100% in 10% steps.

The default RPM steps are 200rpm until 3000rpm, and above this rpm the steps are in 500rpm. The MAP, TPS or RPM steps can be edited via FTManager

Quick access panel		MAP x RPM ignition table (advanced) (° BTDC)							
Fuel Tables		MAP (psi)							
Ignition Tables		° BTDC	-11.60	-10.15	-8.70	-7.25	-5.80	-4.35	-2.9
MAP x RPM ignition table (advanced)		8000	44.0	41.6	40.4	39.1	38.2	37.6	37.3
Overall ignition trim		7600	42.7	40.4	39.3	38.2	37.7	37.0	36.6
TPS auxiliary compensation		6800	40.1	38.2	37.2	36.2	36.8	35.8	35.4
Engine temperature compensation		6000	37.6	35.9	35.1	34.3	35.9	34.7	34.0
Intake air temperature compensation		5200	37.2	36.3	35.8	35.4	35.0	33.5	32.8
Individual cylinder trim		4400	36.7	36.6	36.5	36.4	35.9	34.4	33.6
Ignition limits		3600	36.3	36.9	37.2	37.5	36.8	35.2	34.4
Gear based compensation									
Ignition timing shift compensation									

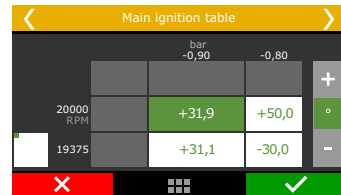

18.2 Overall ignition trim

To apply a quick compensation to the entire ignition map, the Overall Ignition Trim function may be used. It is only necessary to inform the correction, negative or positive, and confirm by pressing the right button. This correction will be added to or subtracted from the entire ignition table based on RPM

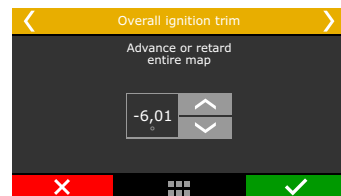
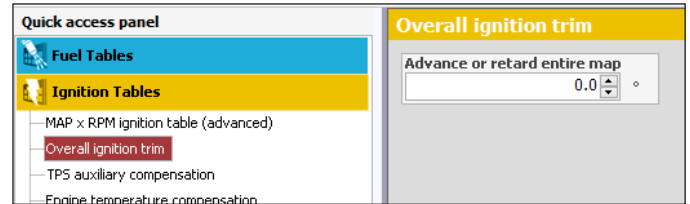

18.3 MAP/TPS compensation

This table changes according to the main map configuration (MAP or TPS). When the main ignition table is setup by MAP, this table is a compensation by TPS. When the main ignition table is setup by TPS, this compensation is by MAP.

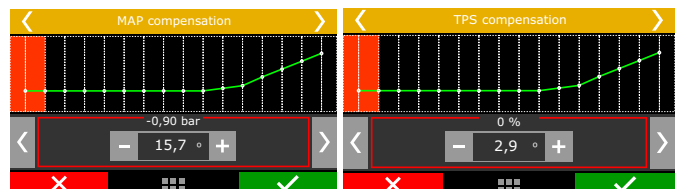
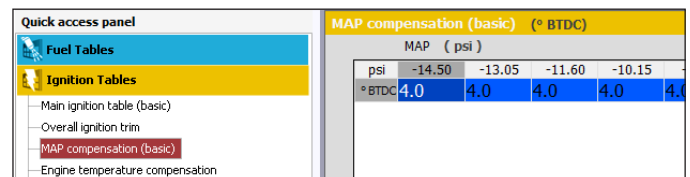

18.4 Engine temperature compensation

This map represents a compensation on the advance or retard angle applied to the main RPM map based on engine temperature variation. It is a very important feature and it brings significant improvement on drivability, especially while operating cold engines, when advanced ignition timing is necessary in order to have a correct response from the engine. It is also essential for engine protection, as it retards the ignition timing when the engine reaches high temperatures.

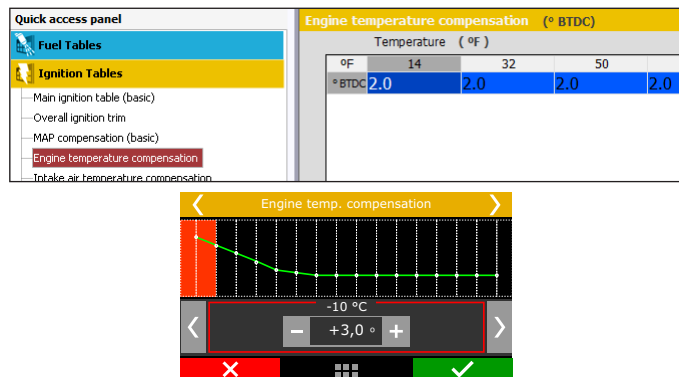

18.5 Intake air temperature compensation

This map represents a timing compensation applied to the main RPM timing map based on intake air temperature variation.

It is beneficial, because the colder the air entering the combustion chamber, the denser it is, and the greater the possible ignition advance is.

But when temperatures are very high (especially on turbocharged engines), the ignition timing must be retarded to protect the engine.

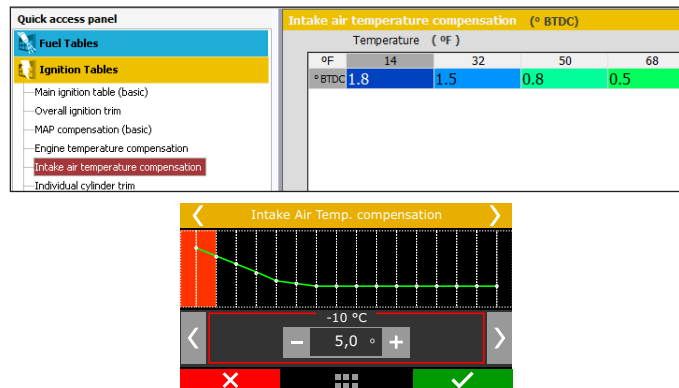

18.6 Rotary timing split

This menu is only shown when controlling Rotary engines, the axis will be set dependent on fueling method (TPSxRPM or MAPxRPM). This is the timing split between Leading and Trailing spark plugs. It is a 3D table of negative timing split values and has 8x8 cells that can be edited through the FTManager software.

The main ignition table will get all the corrections and timing controls applied to the leading spark plugs. The timing split to the trailing spark plugs will be based on the leading final timing values with an applied compensation based on the values listed in the Rotary Timing Split table.

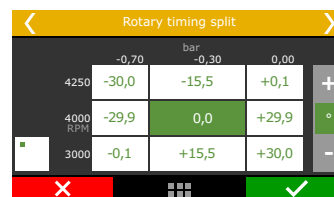
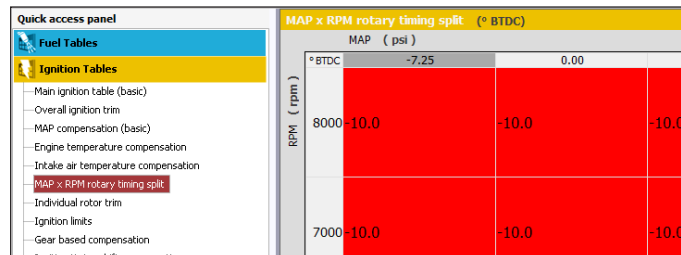

18.7 Individual cylinder trim

Set a timing compensation to each ignition output on a table that relates engine RPM with individual cylinder trim compensation. The timing compensation is done individually to each cylinder according to the engine RPM and it comes from the flow differences, heating dissipation capacity or even cylinder position.

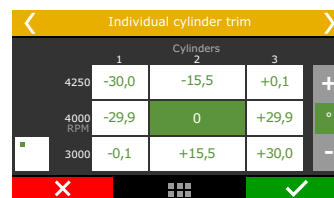
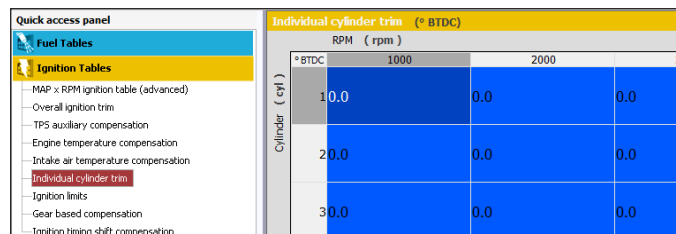

18.8 Rotor compensation

Available only when controlling Rotary engines, this is an individual rotor ignition trim.

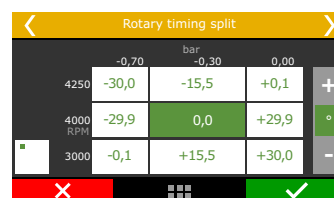
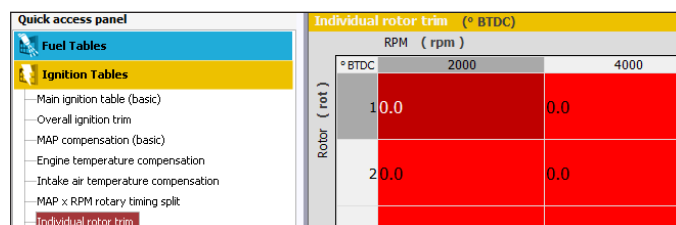

18.9 Timing limits

This menu is used to configure the maximum and minimum ignition timing limits, so the engine won't run in any situation with too much retard or advanced ignition timing. No other function will be able to apply timing beyond these limits. This is a safety feature to prevent an inappropriate timing, considering all the functions that may enable a timing compensation (mainly drag race time based features).

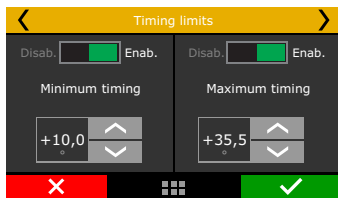
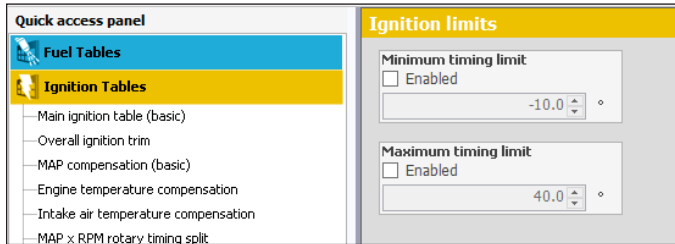

18.10 Engine Start

This is an ignition advance vs engine temperature table. Calibrate the ignition advance for each temperature site.

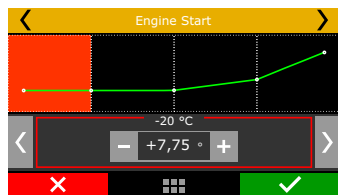
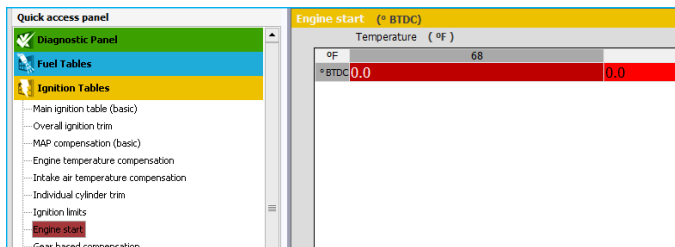

18.11 Gear compensation

This compensation allows advancing or retarding the ignition timing according to the engaged gear. This table applies the compensation in the main ignition table according to engaged gear and RPM.

To enable this option, gear change detection must be enabled. It is possible to set up to 9 compensation tables (10 gears).

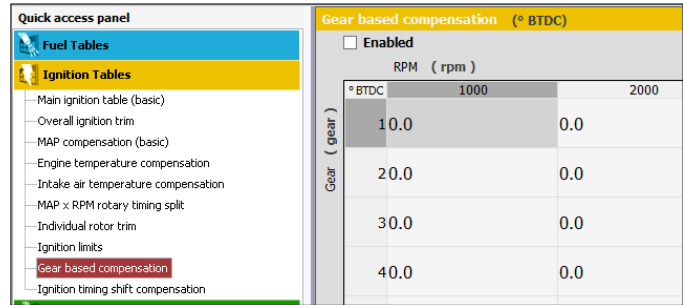
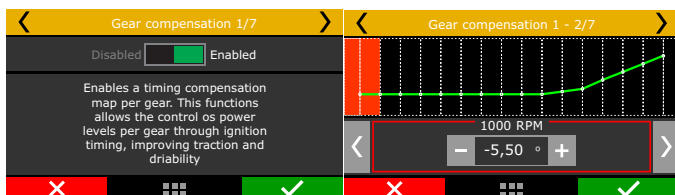

18.12 Gear shift compensation

This function allows advancing or retarding the timing after a gear shift (upshift).

You can enable a TPS condition so the retard can happen.

In the example, there will be a 5° timing retard. The ramp return time is the retard total time, which will be gradually re-established. In other words, after shift gear, timing will be retarded 5°, 0,25s the retard will be 2,5° and 0,50s after the shift there will be no gear shift compensation. To enable this option, gear change detection must be enabled. It is possible to set up to 5 compensation tables (6 gears).

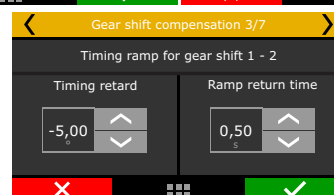
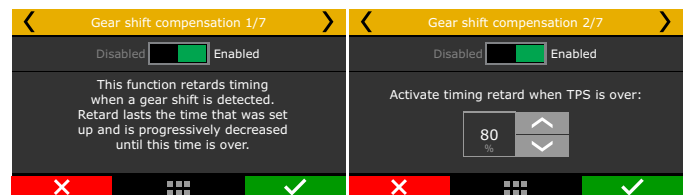
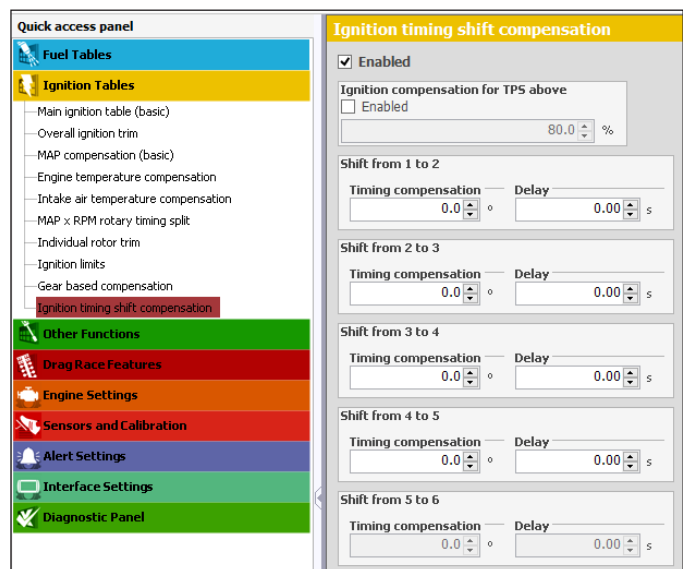

19. Other functions

This menu allows the adjustment of all functions that modify the operation of auxiliary outputs and compensations of idle speed, etc.

19.1 Internal datalogger

This function is used to log all the engine data read by FuelTech ECU. The Internal Datalogger can record up to 256 channels like: injection time (banks A and B), injectors duty cycle (banks A and B), timing, engine rpm, auxiliary output status, TPS, coolant and air temperature, oil and fuel pressure, O2 sensor, two-step button, MAP sensor, camshaft position sensor and battery voltage.

Log download and data analysis are done through the computer and FTManager Software.

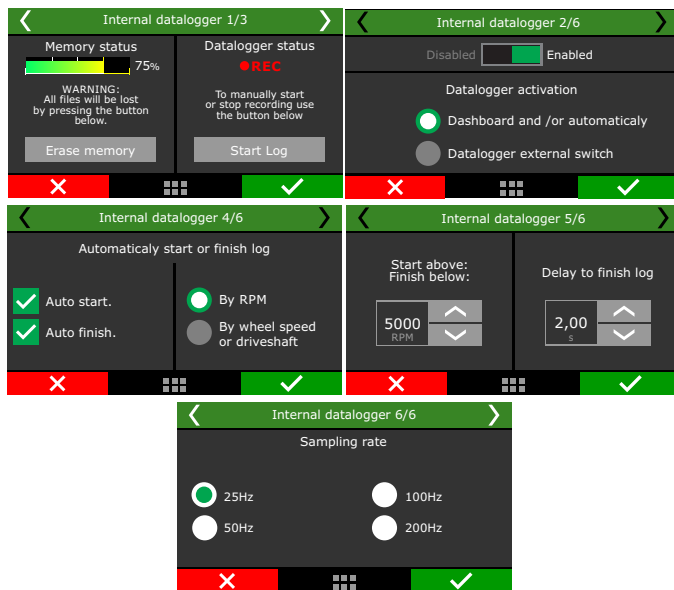
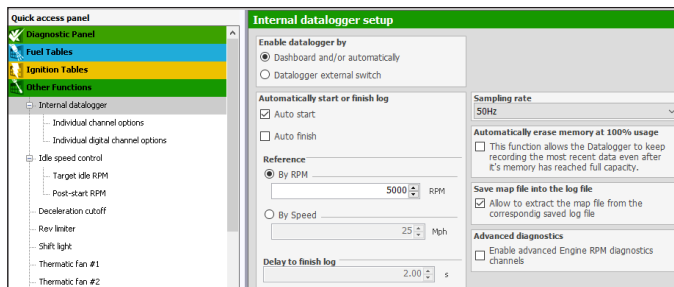

Datalogger enabled

Select if the datalogger is enabled or not and set the start/finish mode. Through dashboard a touchscreen button will start or stop the recording. Through external switch a white input must be wired to an on/off switch to enable the recording. While the input is grounded the datalogger will be recording.

It is possible to choose two modes for the Internal Datalogger:

Basic: All channels are logged with the same sampling rate.

Advanced: allows the user to select the channels that will be logged and their sampling rate. Functions and sensors added after setting the internal datalogger on advanced mode will be automatically logged with the default sampling rate, but this can be changed if desired.

Log start and stop

The internal datalogger start and stop trigger can be set up by RPM signal or by a button on the ECU dashboard.

When selecting "RPM Signal", the log will be started only when the programmed RPM is reached. If a button on the dashboard is preferred, select it on the internal datalogger. After that, go to "Interface settings" menu and set up the datalogger button on a spot under "Dashboard setup".

Log is automatically stopped when memory is full, ECU is turned off or the button is pressed.

Via FTManager software, the log can be started or finished through the "Start log" and "Stop log" in the tool bar. The "Erase memory" will clear all the logs in the FT memory.

Sampling rate

The sample rate defines the log quality. Higher sample rates create more detailed logs, however, the logging time available will be shortened. For competition vehicles, especially drag racing, it is recommended to use a high sample rate to have high detail level on the log.

The **lower** the sample rate, the more "square" will be the graph and less detailed. On the other, the **higher the sample rate**, the more detailed the log.

Automatically erase memory at 100% usage

If this option is checked, the memory will be erased when it reaches 100% capacity, this means older logs will be permanently erased and the recording of new logs will be possible.



NOTE
During the erasing process it's not possible to record a log.

Advanced diagnostics:

Enables the logging of many different advanced RPM signal diagnostic channels such as signal reading noise, pulse timeout, incorrect pulse edge, the count of teeth and others. This is very helpful to diagnose issues with engine synchronization when using Cam sync or RPM signal losses.

Individual channel options

In this menu it is possible to setup each channel individually about line color, if it will be visible or not, its scale and, when in the advanced mode, its sampling rate.

Record	Color	Channel	Sample rate	Visible	Fixed scale
<input type="checkbox"/>		Pressure1_TempStrum_DigitalChannel12-bank	500	<input type="checkbox"/>	<input type="checkbox"/>
<input type="checkbox"/>		Pressure1_TempStrum_DigitalChannel22-bank	500	<input type="checkbox"/>	<input type="checkbox"/>
<input type="checkbox"/>		Pressure1_TempStrum_DigitalChannel32-bank	500	<input type="checkbox"/>	<input type="checkbox"/>
<input type="checkbox"/>		Pressure1_TempStrum_DigitalChannel42-bank	500	<input type="checkbox"/>	<input type="checkbox"/>
<input type="checkbox"/>		TPS	500	<input type="checkbox"/>	<input type="checkbox"/>
<input type="checkbox"/>		Idle #1	500	<input type="checkbox"/>	<input type="checkbox"/>
<input type="checkbox"/>		MAP	500	<input type="checkbox"/>	<input type="checkbox"/>
<input type="checkbox"/>		Battery voltage	500	<input type="checkbox"/>	<input type="checkbox"/>
<input type="checkbox"/>		Throttle position	500	<input type="checkbox"/>	<input type="checkbox"/>
<input type="checkbox"/>		Auto code history	500	<input type="checkbox"/>	<input type="checkbox"/>

Internal datalogger status

At the Dashboard Screen of the ECU, a round icon is shown besides engine RPM. This icon indicates the Internal Datalogger status.

- Internal datalogger **stopped**: Grey "Data" button
- **Recording**: green "Data" button, blinking light **red** icon with the word **REC**
- **Memory full**: red "Data" button with the word **FULL**



NOTE
When memory is full, connect the ECU to the PC and download the data through FTManager Software.

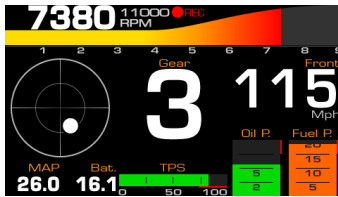

Log download

The log download must be through FTManager. Connect the FT to the computer with the USB cable



Open the FTManager, and click on the Datalogger icon. The FTManager Datalogger will open. To download, click on the Download icon and a window will pop up showing all logs saved on the ECU. Select the files and click OK.

The datalog software will open. Use the mouse to browse the graph and check the values on the left panel.

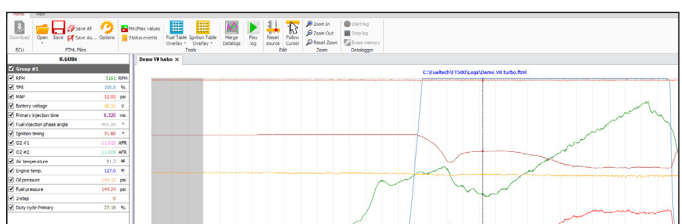
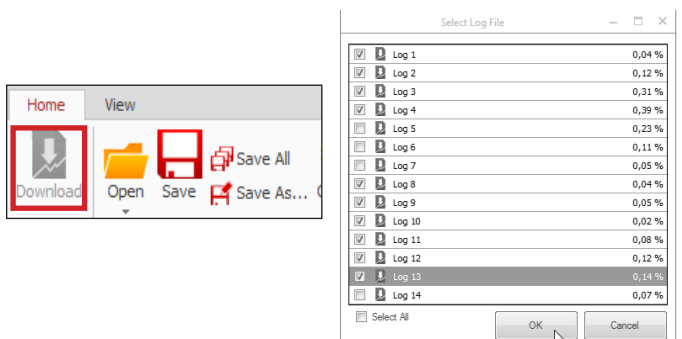

19.2 Accelerometer and gyroscope (FT550 and FT600)

FT has an internal 9-axis accelerometer which provides the following data:



NOTE
See section 15:19 for the accelerometer calibration.



WARNING
In order for the accelerometer and gyroscope to work properly and have correct readings, a calibration of the sensor is required. The FT should be installed as vertical as possible.

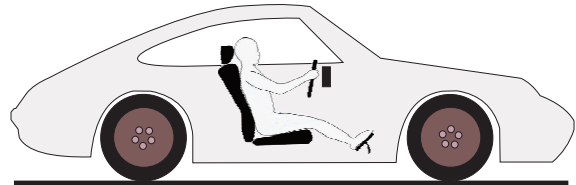

G-Force acceleration: records the vehicle's acceleration force.

G-Force braking: records the vehicle's braking force.

Pitch angle: records the vehicle's pitch angle.

Pitch rate: records the vehicle's pitch rate.

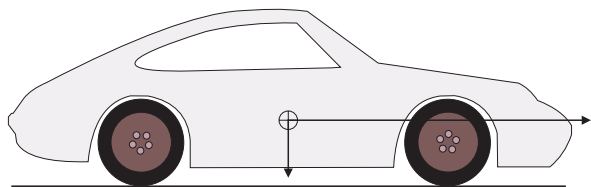
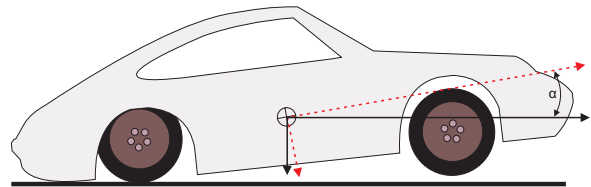

Lateral G-Force: registers the vehicle's lateral force.

Roll: registers the vehicle's roll angle.

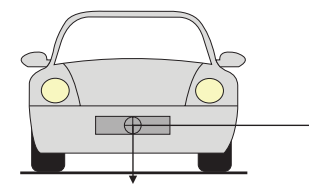
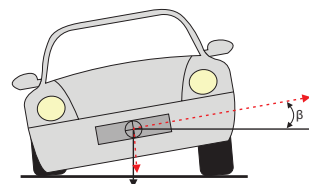

Speed under acceleration: calculates the speed based on the vehicle's acceleration.

Distance under acceleration: measures the traveled distance based on the vehicle's acceleration.

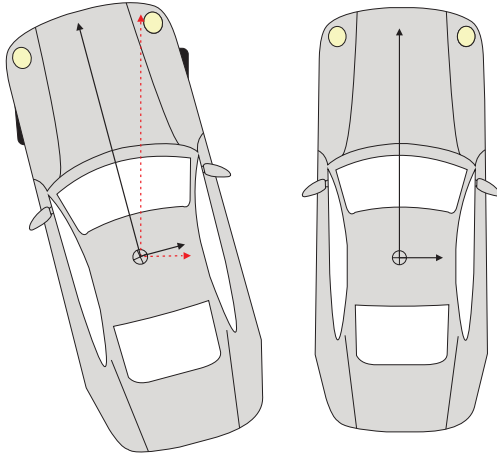

Direction: records the calculated position in degrees based on the moment the vehicle launched.



NOTE
 The features: speed under acceleration, distance under acceleration, roll angle and pitch angle are calculated only after a valid launch (when with the 2-step activated the engine hits TPS higher than 50% or the 2-step rev limiter).

19.3 Idle speed control

This FT can control idle speed through electronic throttle, step motor, PWM valve and by timing.

To enable the idle speed control by electronic throttle, it is needed to setup the menu "Electronic throttle" under "Engine setup" menu. After that, you can follow this menu to setup idle parameters.

Actuator reaction level: this parameter is the aggressiveness that the timing and the actuator will be changed of position in order to control a RPM fall. The higher this number, the more aggressive is the reaction of the control.

High reaction levels may lead the idle speed to be unstable.

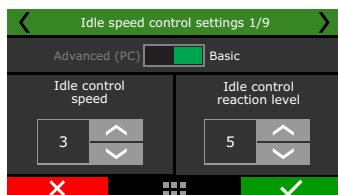
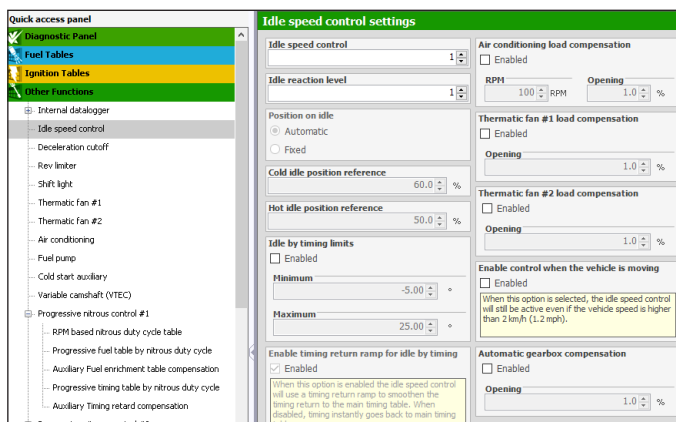

Position on idle

Automatic: in this mode, idle actuator is automatically opened and closed by the ECU in order to make the engine idle near the target RPM.

Fixed: in this option, idle actuator assumes a fixed position, set up later according to engine temperature.

ETC reference position: this parameter is the actuator position when the engine is turned off or cranking. It is also used as a stable reference during the automatic idle speed control. Setup a value that's enough for a cold start of the engine. Start with a value around 4% for electronic throttle and 30% for step motor.

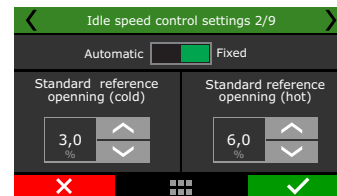

Idle speed by timing

This control uses a target RPM for idle speed and works by advancing and retarding the engine timing to keep the engine running near the specified RPM.

As the FT idle speed control has an advanced integration with the idle speed by timing control, this one stays always enabled when any other kind of idle speed control is selected. By doing this, the idle speed actuator is always kept in a position where the idle speed by timing control can set the timing away from the maximum and minimum timing positions.

Maximum and minimum timing limits: these values are the limits for advance and retard when ECU is controlling the idle by timing.

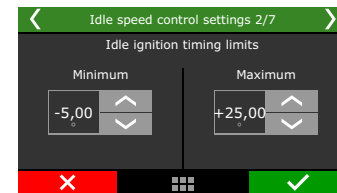

Actuator position

This parameter will be only available when the position on idle is set as fixed. This table relates the actuator position in function of the engine temperature.

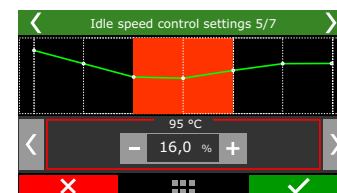
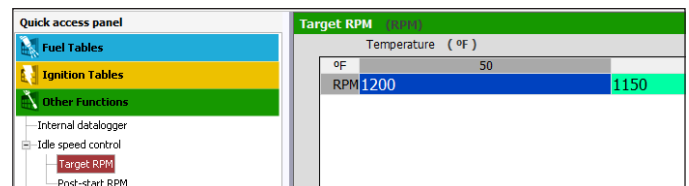

Post-start position

This parameter will be only available when the position on idle is set as fixed. The table controls the actuator opening after the engine start. The table is an actuator position vs time. After the time slip, the position is defined by the actuator position table based on engine temperature.

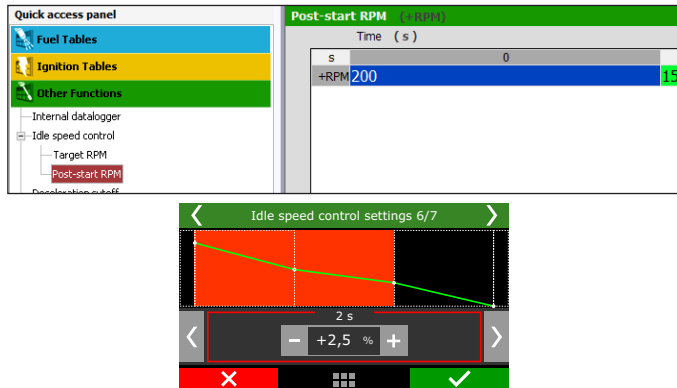

RPM for idle speed

This table tells the ECU the target RPM the idle control will assume, according to engine temperature. On intermediate temperature ranges, target RPM is automatically interpolated.

When "Position on idle" is set to "fixed" this table represents the actuator position X engine temperature.

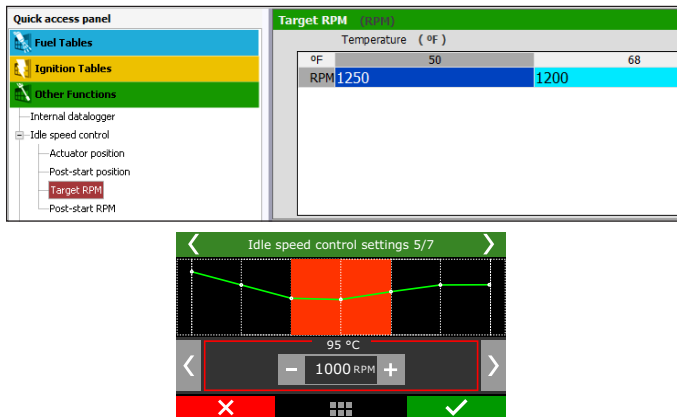

Post-Start position

This parameter is a RPM increase (or % of increase in the actuator position for fixed idle position). The table shows the actuator position according to time post engine start.

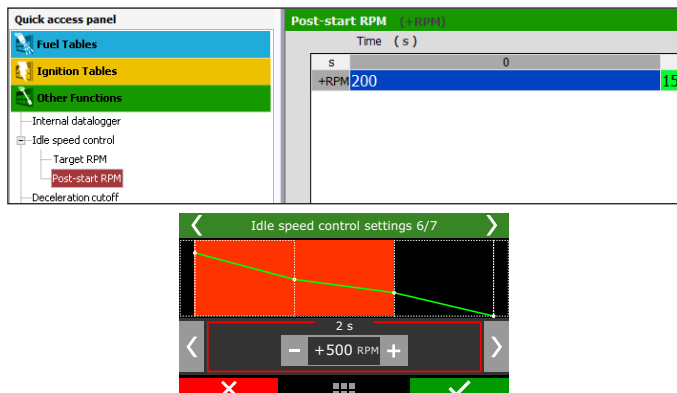

Compensation by load: used to compensate actuator position when suddenly loads (like AC or fan) are added to engine and can affect idle. It is possible to set a target RPM compensation when the AC is on and fuel/actuator opening compensation for AC and fans.

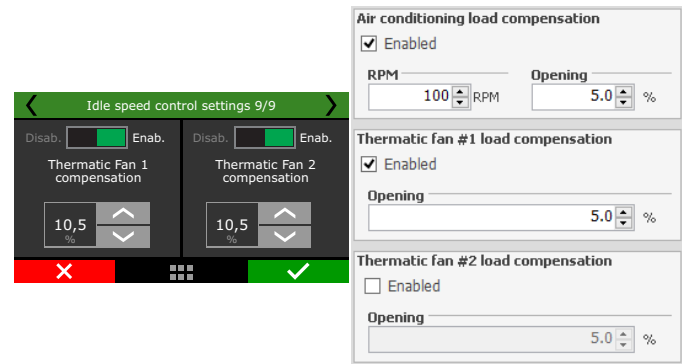

Idle speed control on movement: when this option is checked the idle speed control will turn on when the TPS percentage is 0% and the engine RPM is 700 rpm above the set target.

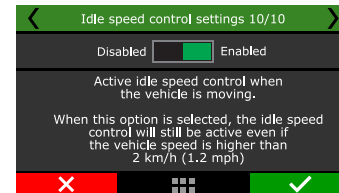

Return ramp: When enabled, it generates a return ramp for the ignition timing. If this function is disabled, when the idle control is operating the ignition timing will be set as the minimum defined for the condition. When the idle control is off, the ignition timing will return for the value set at the ramp.

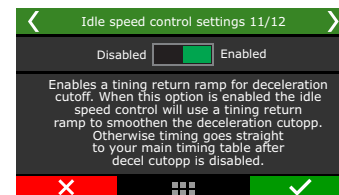

Compensation by automatic transmission: If the vehicle is equipped with an automatic transmission it may be necessary to set a compensation for adding a certain amount of air flow in idle control, once the automatic transmission applies an additional load at the engine.

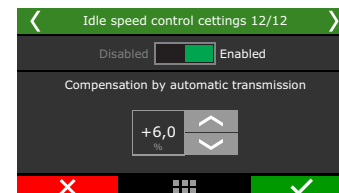

Advanced configuration

For advanced idle speed control options go to Engine settings menu, Advanced map options and select Idle speed control as Custom.

Timing compensation: it is used when a load is detected (electric fan or AC). Timing is immediately applied when load is detected, after that the control acts advancing or retarding timing if needed (default 7°).

Target approach rate: used to reach RPM target, also responsible for control reaction speed (default 6RPM/s).

Deadband: dead zone the control considers as on target. Example: target 800RPM, deadband 50RPM. From 750RPM up to 850rpm the control will be stable (default 50RPM).

Approach RPM: added to the target RPM where the control starts to act (this makes the control smoother). When RPM reaches this number the control uses the target approach until it reaches the RPM target within it's deadband.

Boundary RPM to enable: indicates the minimum RPM to the ECU consider Idle, added to the Idle target, for example idle target at 1000RPM, plus 700RPM boundary RPM equals to 1700RPM for idle control strategy.

Proportional gain (KP): responsible to identify if the RPM is close or too far from the target, acting according to the number, high numbers can make it instable.

Integral gain (KI): responsible for RPM trend, to identify and make changes to reach the target.

Derivative gain (KD): evaluates the RPM back in a recent period of time and has been done to be in the actual engine RPM, will provide data to the next sequences of control.

Advanced options

Timing compensation 7.0 °	Target approach rate 3 RPM/s
Proportional gain (KP) 15	Deadband 50 RPM
Integral gain (KI) 20	Approach RPM 300 RPM
Derivative gain (KD) 60	Boundary RPM to enable 700 RPM

19.4 Deceleration cut-off

The purpose of Deceleration cut-off is to improve fuel economy when the engine is at 0% throttle situations.

This aids in the deceleration of the vehicle by making use of engine braking while driving in traffic. This function is valuable to the reduction of fuel consumption

On a circuit racing or auto cross vehicle is utilizing heavy braking going into a turn, it is necessary that it has a quick and clean response from the engine upon re-opening the throttle.

Deceleration cut-off will aid in dynamic braking from the engine as well as overall fuel economy.

A standard RPM of 2000rpm is recommended. Setting a very low RPM may cause the engine to turn off involuntarily during deceleration

The "Cut-off Delay for TPS=0%" parameter is the time (in seconds) delay before fuel is actually cut-off after releasing the throttle. Such delay exists to prevent the engine from instantly becoming lean when the throttle is released. It also rapidly cools the combustion chamber without being excessive, and avoids situations in which the cut-off might oscillate, especially when the throttle is lightly pressed. A standard delay of 0.5s is suggested.

Such delay exists to prevent the engine from instantly becoming lean when the throttle is released.

In order to have the Deceleration cutoff working along with Anti-lag / Pops & Bangs / Engine brake is necessary to enable it according to the following image.

Deceleration cut-off

Cut when TPS=0 and RPM is above: 2800 RPM

Cut delay: 2.0 s

Anti-lag / Pops & Bangs / Engine brake

Enable fuel cutoff during Anti-lag / Pops & Bangs / Engine brake

Deceleration cut-off 1/2

Disabled Enabled

Cut when TPS=0 and above: 2500 RPM

Cut delay: 0.5 s

Enable fuel cut-off during Anti-lag / Pops & Bangs / Engine brake

19.5 Revolution limiter

This function is very important for engine protection, limiting the RPM with two different options of cut-off:

Fuel Injection: the fuel injection is cut-off instantly, as the ignition is still operating. It is a very smooth and clean cut-off. Recommended only for naturally aspirated engines, it is the standard setting in vehicles with original injection systems.

Ignition: the engine ignition is cut-off when the configured RPM is reached. It is recommended for high-power engines, especially turbocharged ones, being the most efficient and safe option.

Revolution limiter

Cut type

Ignition

Fuel

Revolution limiter

Single value

8000 RPM

Engine temperature table

Gear based table

Rev limiter RPM signal

Automatic (Legacy)

Normal RPM

High-resolution RPM

Ignition timing on Rev. limiter

Enable

Fixed timing: 0.0 °

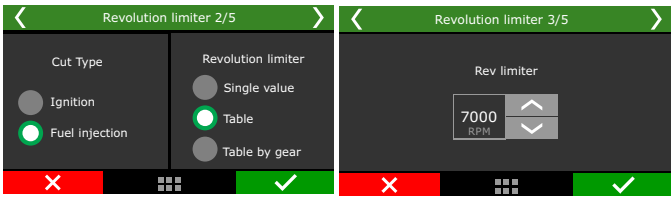

Rev limiter by engine temperature

When the option “table by engine temperature” is selected, it’s possible to set different rev limiters according to engine temperature

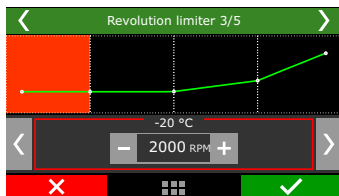
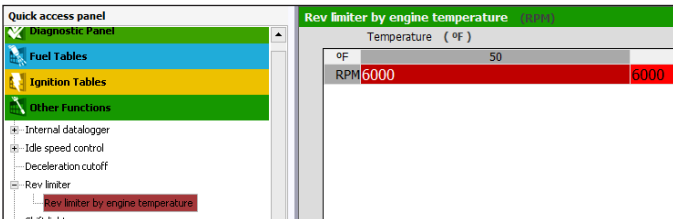

RPM Signal for Limiter: There are three selection modes. Automatic, Normal RPM, or High-resolution RPM.

Ignition timing on Rev. limiter: Set the ignition timing target for the RPM limiter.



19.6 Shift Light

When the engine reaches the RPM set in this parameter, the screen will display a blinking message (“SHIFT”) indicating that gear must be shifted.

To switch an external shift light, it is necessary to configure an auxiliary output at the “Input and Output Setup” menu. If no auxiliary output has been configured as Shift Light, the message “Output not configured!” will be displayed. Even so, it is possible to set the Shift Light RPM on the screen

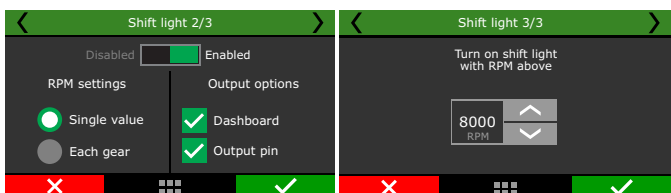
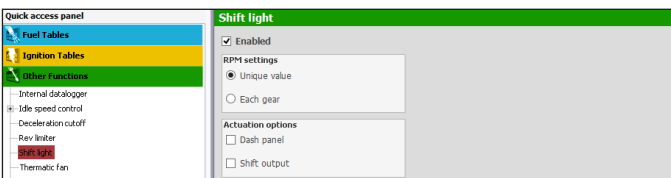

19.7 Thematic Fan #1

There are two ways to set up the control of the thematic fan #1, either by an on/off command or a PWM proportional control.

ON/OFF: The thematic fan will switch on/off depending on the temperatures that are set. There’s also the option to turn on the thematic fan when the A/C is on, to do so select “turn on with A/C”

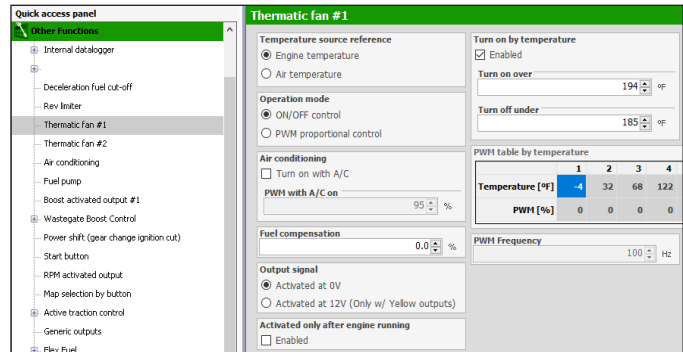

There’s an option that allows one of the fans to be activated when A/C is turned on. As these fans may draw considerable load, a fuel compensation is also available.

To test the fan output, just click on the “Test output” button. If it doesn’t work, check the install or test another output.

Through FTManager, the output configuration is done in the “Sensors and calibration” menu - Outputs.

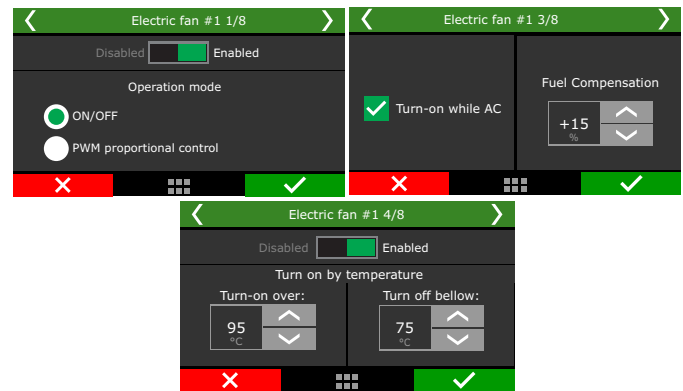

PWM proportional control: The thematic fan will be controlled by a solid state relay via PWM control, this creates a very linear and progressive control of the engine temperature.

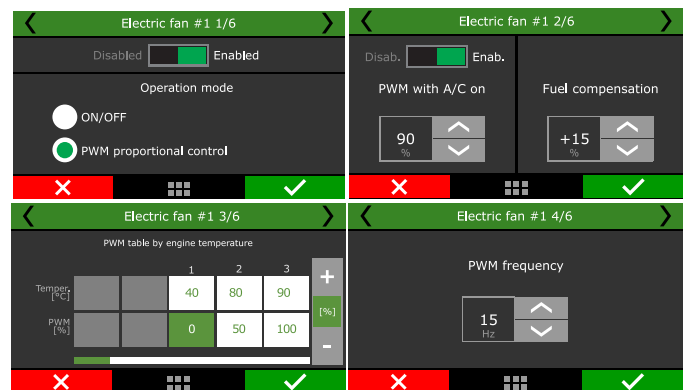

Both modes of operation can be set according to the air or engine temperatures.

Engine temperature: The most commonly used, the control is made by the temperature in the cooling system.

Air temperature: This option may be used for cooling the air of a turbocharged engine equipped with a watercooler or water pump, or even to drag race diesel engine tractors where water is injected inside the combustion chamber for cooling.

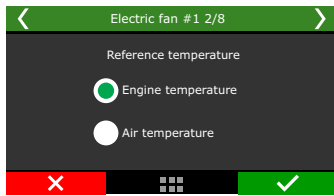

Activated only after the engine is running: the option enables the fan output only after the engine is running, above configured RPM for engine start.

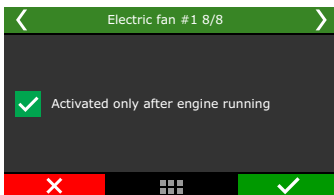

19.8 Thematic Fan #2

This FT can control up to two cooling fans on different temperatures. There's an option that allows one of the fans to be activated when A/C is turned on. As these fans may draw considerable load, a fuel compensation is also available.

To test the fan output, just click on the "Test output" button. If it doesn't work, check the install or test another output.

Through FTManager, the output configuration is done in the "Sensors and calibration" menu - Outputs.

Activate only after engine running: the option enables the fan output only after the engine is running, above configured RPM for engine start.

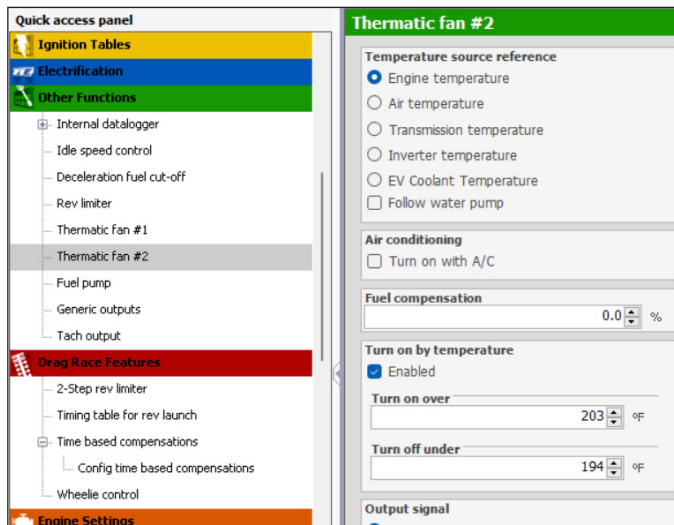

Both modes of operation can be set according to the air, engine temperatures or follow water pump.

Engine temperature: The most commonly used, the control is made by the temperature in the cooling system.

Air temperature: This option may be used for cooling the air of a turbocharged engine equipped with a watercooler or water pump, or even to drag race diesel engine tractors where water is injected inside the combustion chamber for cooling.

Transmission temperature: with this option it's possible to use electric fan #2 for transmission oil coolers.

Inverter temperature: used for electrified vehicles that require inverter temperature control.



19.9 Air conditioning

To control air conditioning through FT, first you have to setup an output to control the A/C relay. Then, setup the input that will receive signal from the A/C button on the car dashboard. Check chapter 13 for more information.

Adjust the percentage of "Fuel enrichment" for the air conditioner activation, this prevents the engine from having a drop in rpm when turning ON the A/C compressor.

The turn on delay will happen in 3 different situations:

- When starting the engine with the AC button turned on, the turn on delay will start to count after the RPM for engine start is overcome. In this case, the reference is engine start, not the moment when the AC button is switched on.
- When turning off and then turning on the AC button, the turn on delay will count from the moment the AC button is turned off. If the time between turning off and then turning on is bigger than the turn on delay set, the AC will be immediately activated.
- When the engine RPM is below the minimum RPM the turn off is immediate. The delay will count from the moment the RPM is below the minimum RPM. To turn on again, the delay will start to count when the engine RPM is 50RPM higher than the minimum.

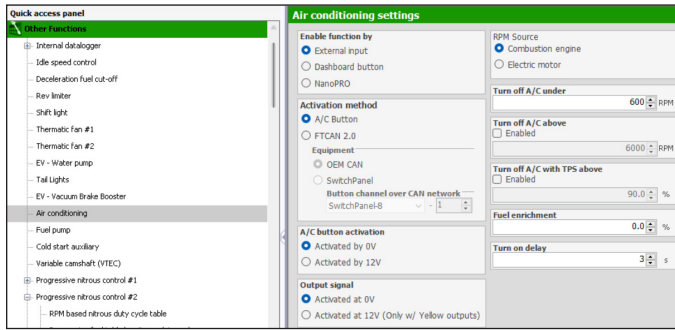

When selecting “External button”, it is necessary to select which input will be responsible for activating the air conditioning. It is also possible to select an input via the CAN network.

Configure the output to activate the A/C compressor, choose if the activation will either be by 0V (blue or gray outputs) or 12V (yellow outputs).

You can also configure the A/C shutdown conditions to make better use of the engine’s power.

RPM Source: this option allows you to choose where the RPM signal will come from to activate the function. There are two options, combustion engines or electric motors.

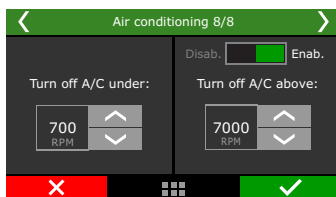
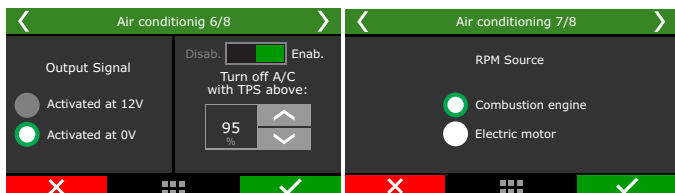

19.10 Fuel pump

This output activates the fuel pump relay through lowside (0V) or highside (12V).

You can choose from the following options:

Always enabled (the output is permanently activated while the ignition switch is on)

Timed (when the ignition switch is turned on, the output is activated for a defined activation time, afterwards the output is deactivated. When engine speed signal is received, the ECU reactivates the

output.). **During start** (when the output is activated while it’s below the starting engine speed).

It’s required to use a relay that supports the necessary current for the fuel pump. Through the FTManager software, the output configuration is done through the menu “Sensors and calibration” and then “Outputs”

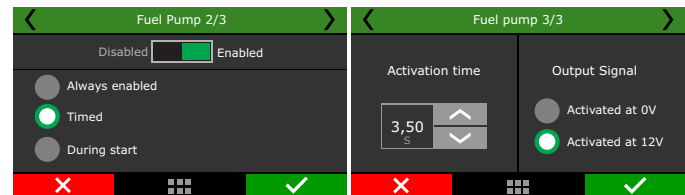
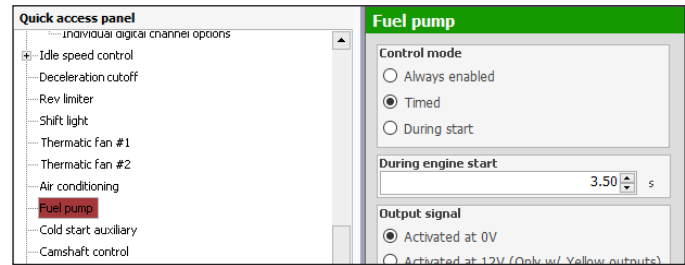

19.11 Cold start auxiliary

This feature is very useful for cold starts on methanol and alcohol engines using a gasoline injection auxiliary kit. The table shows the auxiliary injector time versus temperatures.

The ECU will activate the output according to the time set on the table once it detects the first tooth from engine RPM on every engine start. The cold start auxiliary is disabled when cranking the engine with the accelerator pressed with TPS above the value set in the parameter “Disable injection on engine start with TPS above” in the “Injection” menu, under “Engine settings”.

Output signal: Activation through 0V in the blue or gray outputs. The yellow outputs have the possibility to activate the outputs through 12V.

Time versus temperature curve: This table is composed of a pulse in seconds of the cold start injector depending on engine temperature.

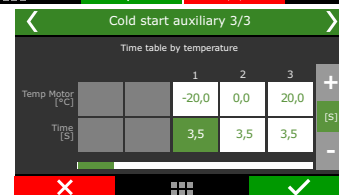
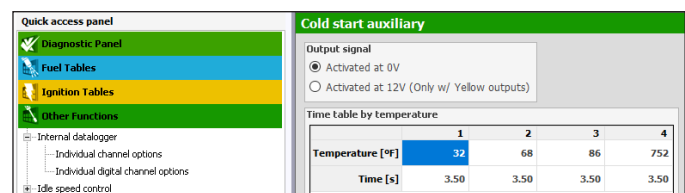

19.12 Camshaft control

This function allows the control of a variable valve timing control system (or a drag racing 2-gear automatic system). Select the output used to control the camshaft solenoid, and then, inform the RPM that the solenoid must be turned on. Only on/off camshaft systems can be controlled.

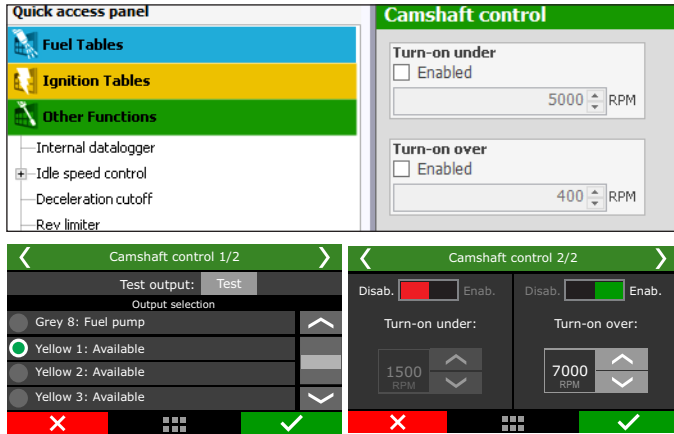

19.13 Progressive nitrous control #1 and #2

This auxiliary output configuration gives access to setting the ratio for the fuel-nitrous mixture (or nitrous only) through pulse-width modulation (PWM) sent to the solenoids.

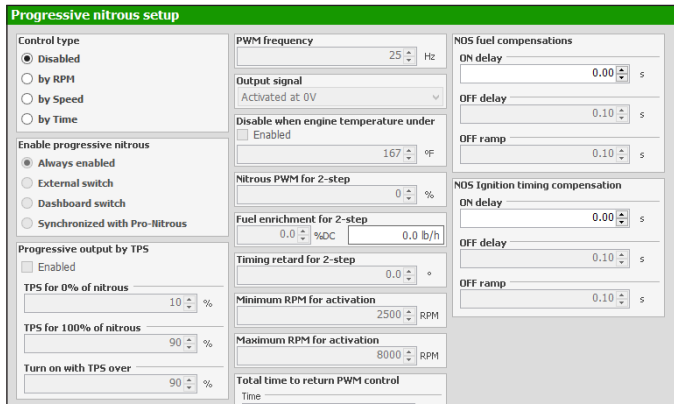

Select an auxiliary output as "Progressive nitrous output" and how the control will be performed: by time (after 2-step), by rpm or by wheel speed.

Also, select the enable mode:

Always enabled;

External switch: select a white input. When the input is grounded the progressive nitrous will be enabled;

Dashboard switch: a touchscreen button must be configured to enable or disabled the progressive nitrous;

Synchronized with Pro-Nitrous: the progressive nitrous control will activate when the Pro-Nitrous (Drag race features menu) conditions are met;

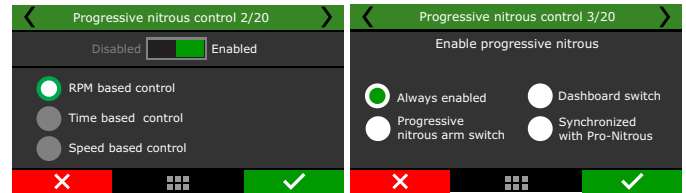

The first parameter to be configured is the TPS opening percentage, above which the injection of nitrous will be activated.

The next parameter is the percentage of fuel enrichment for 100% nitrous.

After this, set the PWM output frequency and the output signal. To regular solenoids, use between 25 and 30Hz, big shot solenoids use 50Hz. The next screen will show the engine temp protection, where you can define a minimum engine temperature for progressive nitrous.

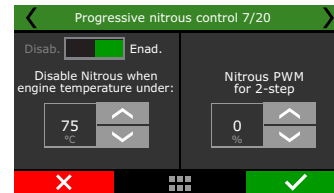
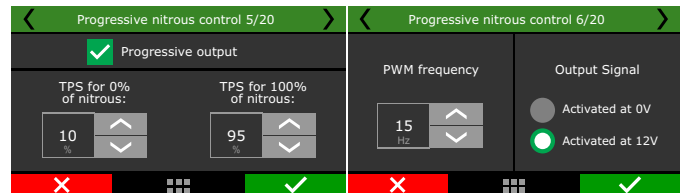

The fuel enrichment for 2-step is a fuel compensation when the 2-step is enabled. The timing retard for 2-step is a compensation applied to the timing configured in the 2-step function. The minimum and maximum RPM is a RPM window and work as a safety feature, so the progressive nitrous will only active if the engine rpm is inside the window. The total time to return PWM control is a delay ramp to reactivate the progressive nitrous when it is disabled by any safety features or switch. This ramp avoids the progressive nitrous to return in a big shot, helping the traction on pedaling.

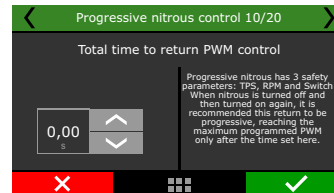
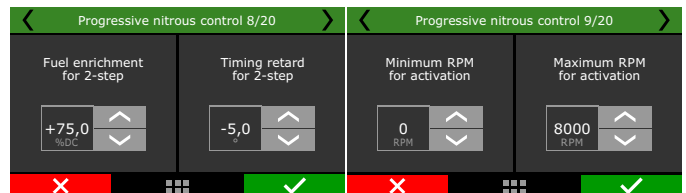

Next is the nitrous injection map based on RPM. The higher the percentage configured in this map, the higher the amount of nitrous (or nitrous + fuel) injected

The maximum RPM is the same chosen on "Fuel Injection Setup".

With the FTManager you can edit axis and add or remove cells.

When using 2 injector banks the fuel enrichment will happen on both.



The ON delay for NOS fuel compensation avoids the extra fuel to get earlier than the NOS in the cylinder, very common when the fogger is far from the injectors.

The Progressive fuel table by nitrous duty cycle and the Auxiliary fuel enrichment table compensation are related to the percentage of fuel added according to %DC of nitrous or engine load/rpm.

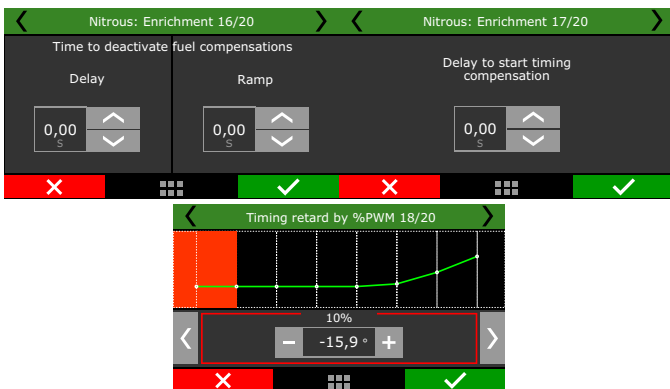

After the end of nitrous shot, normally is necessary to keep the compensations on for a few tenths of seconds, since the intake is full of nitrous that will be consumed by the engine. The OFF ramp makes the compensation ends smoothly.

The delay to start the timing compensation has the same purpose of fuel compensation, the time nitrous takes to reach the cylinder.

The Progressive timing table by nitrous duty cycle and Auxiliary timing retard compensation are related to the timing retard (always negative values) according to the %DC of nitrous and engine load/rpm.

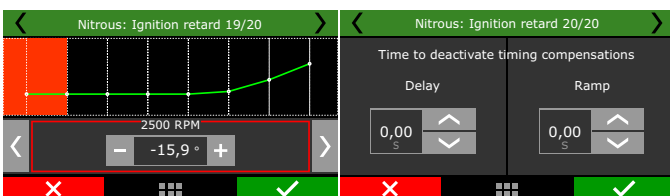

In the end, there are the OFF delay and the OFF ramp and are used to keep the engine safe, avoiding an immediate timing advance that could damage the engine.

19.14 Generic duty cycle output

This feature allows the control, through PWM, of a solenoid valve that manages the wastegate valve, therefore regulating the boost pressure. Through an external button, you can activate the Boost+ function (optional use), which is an instant increase in the boost %DC while the Burton is turned on.

FuelTech recommends using a 3-way button N75 solenoid.

For more information about its installation, see chapter 13.8 in this manual.

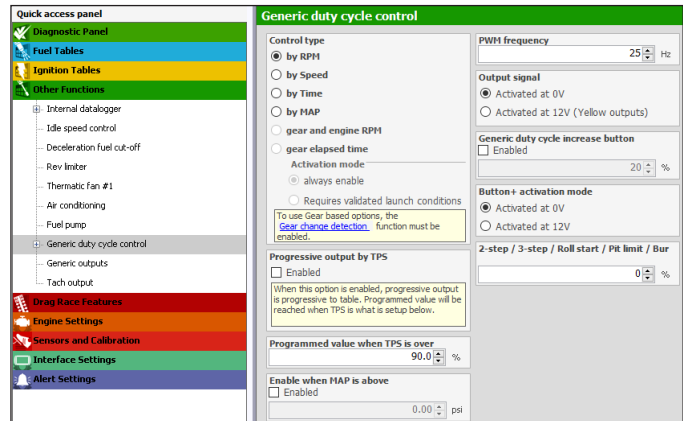

The first parameter is the output which will drive the boost solenoid. Select among the available outputs. After this, select the Boost+ input, if necessary.

In the FTManager, this setting is done in the "Sensors and calibration", then "Inputs" and "Outputs".

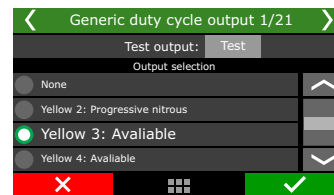

The next screens allow to quickly enable or disable the control, and choose the control mode: by RPM, by time, by speed, by MAP, by gear and Engine RPM and gear elapse time. Time control starts after 2-step is deactivated.

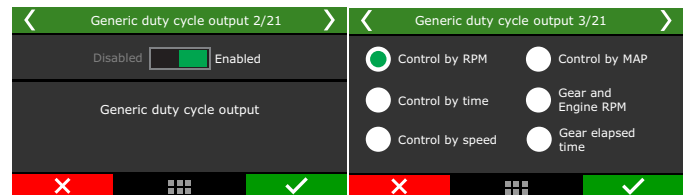

When selecting the option "Gear elapsed time", it is necessary to define whether the function will always be activated or only after a valid start (after the 2-step validation).

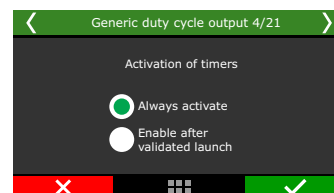

“Programmed boost when TPS is over” is the minimum TPS value to activate the boost solenoid. When the progressive output is selected, boost output is progressive to boost table, starting at 10% to the “Programmed boost when TPS is over” value.

- The recommended frequency for most PWM 3-way valve is 20Hz. The output signal depends on the solenoid installation. Check Chapter 13.8 for further information.
- Select if you want to use the Boost+ button.

The boost duty cycle for 2-step is the boost level when the 2-step is on, which overrides any other boost table.

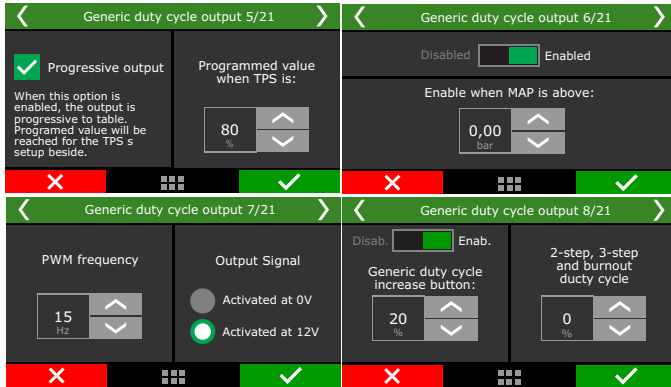

Once your parameters are setup in there will be boost duty cycle table by rpm, speed or time. The boost by time starts after the 2-step release.

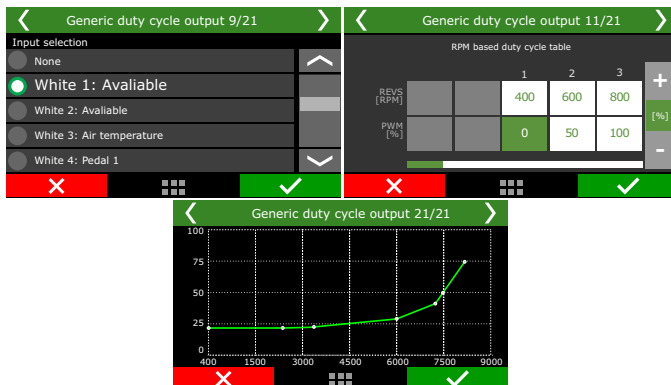

19.15 Boost activated output #1 and #2

This function is used to activate an auxiliary output according to MAP readings.

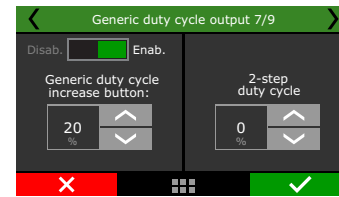
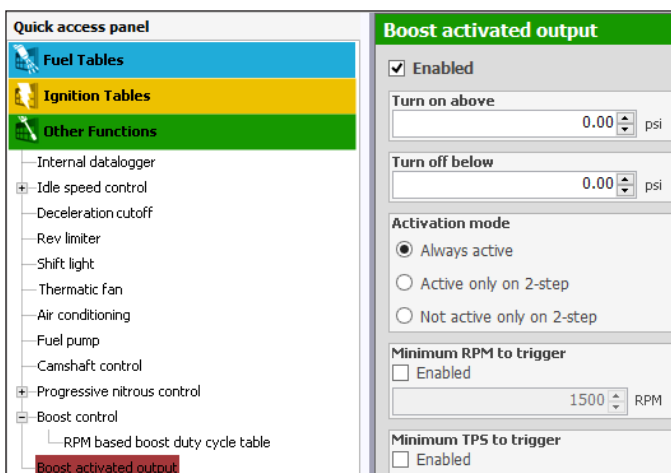

Select an available output to trigger a relay or any other external device. In the FTManager, this setup is at “Sensors and calibration” - “Outputs”

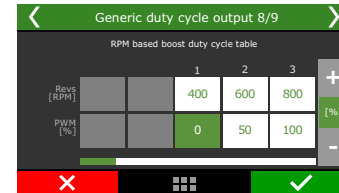

Select the output signal sent when it is activated. The only outputs capable of switching 12V are the yellow.

Define the vaccum/boost range to trigger the output.



There are 3 different activation modes: “always active”, “active only on 2-step” or “Not active only on 2-step”. This means that even if the vacuum/boost conditions are met, the activation mode condition must be respected.

As safety features, minimum TPS and RPM values can be set, so the output will not activate if one or more conditions are not met.

19.16 Tachometer output

By default, the tach output is configured on the gray #8 wire (FT550 and FT600) and gray #4, blue #3 and blue #6 (FT450), but can be set on one of the yellow wires also.

If one of these outputs is not available, the blue and gray can also be used, but an external 12V pull-up with a 1K resistor.

In the FTManager, this setup is at “Sensors and calibration” - “Outputs”

Trigger mode

Synced: Uses same RPM reading

Unsynchronized: Used to adjust RPM through pulses around the engine.

19.17 Wastegate boost pressure control #1 and #2

The active control function of the wastegate valve pressure is used for a more precise control of turbo pressure in street, circuit and, mostly, drag race cars. The control can be performed by time after 2-step, by gear and engine RPM, by gear elapsed time, by a single target or by engine RPM, besides specific targets for 2-step, 3-step and burnout mode.



IMPORTANT

- The pressure controlled by BoostController is the pressure at the top of the wastegate valve.
- You can set the maximum MAP pressure and maximum MAP pressure on 2-step.
- When the BoostController is off the target is zero, and each time the read pressure, for any reason, exceeds 1.45psi the decrease solenoid is activated.

Diagram with injectors block

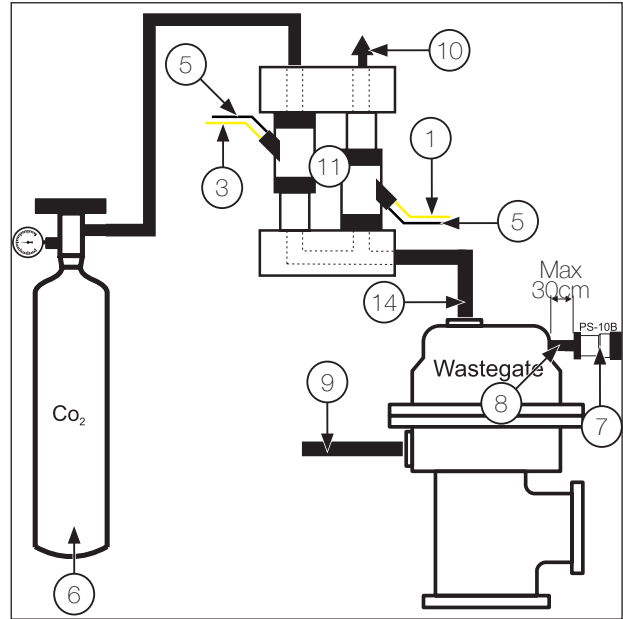

Installation diagram

- 1 - Decrease solenoid/injector trigger – connected to the yellow output
- 2 - Decrease solenoid
- 3 - Increase solenoid/injector trigger – connected to the yellow output
- 4 - Increase solenoid
- 5 - Negative
- 6 - Intake or CO2 bottle
- 7 - Pressure sensor
- 8 - Pressure sensor hose
- 9 - Intake;
- 10 - Free air
- 11 - Injectors block
- 12 - 3 way Valve or N75
- 13 - Actuation of 3 way valve or N75
- 14 - Control pressure Wastegate
- 15 - FT dual valve block
- 16 - Connection to second Wastegate or must be blocked

Diagram with 3 way Valve

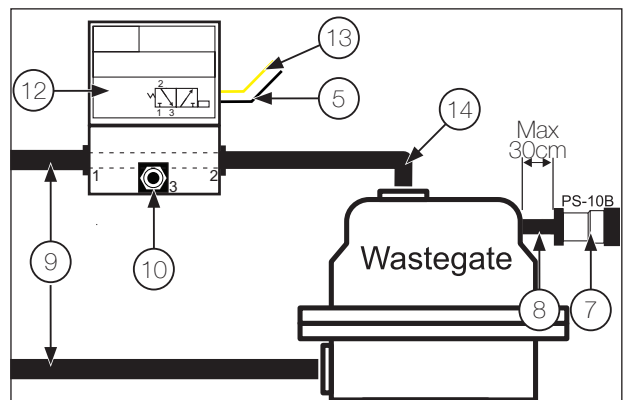

Diagram with regular solenoids

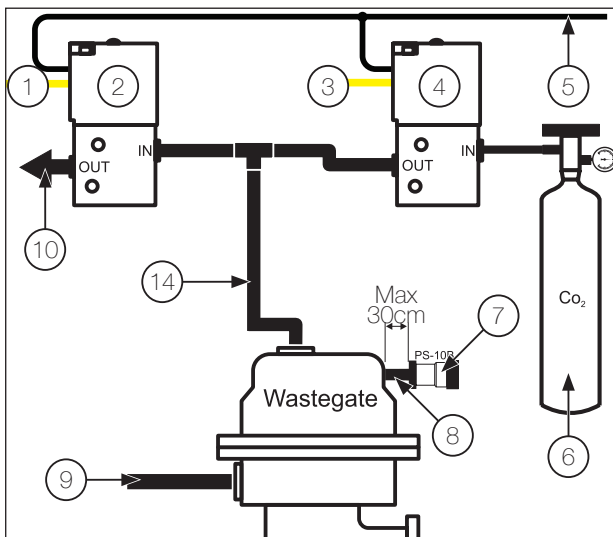

Diagram with N75 Valve

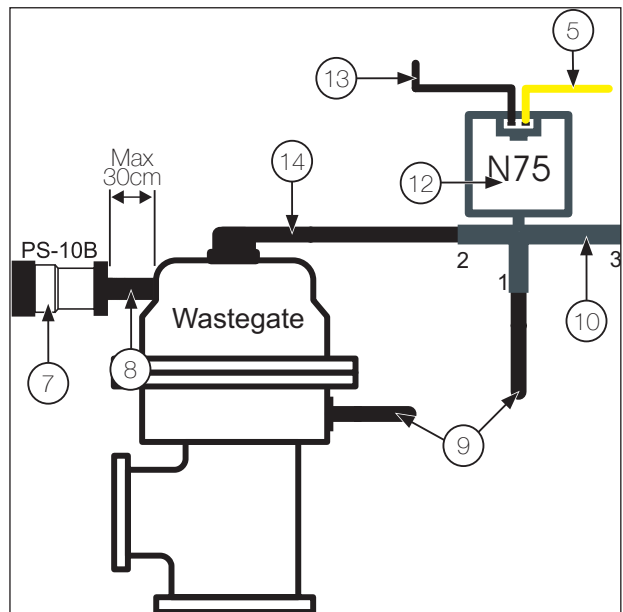
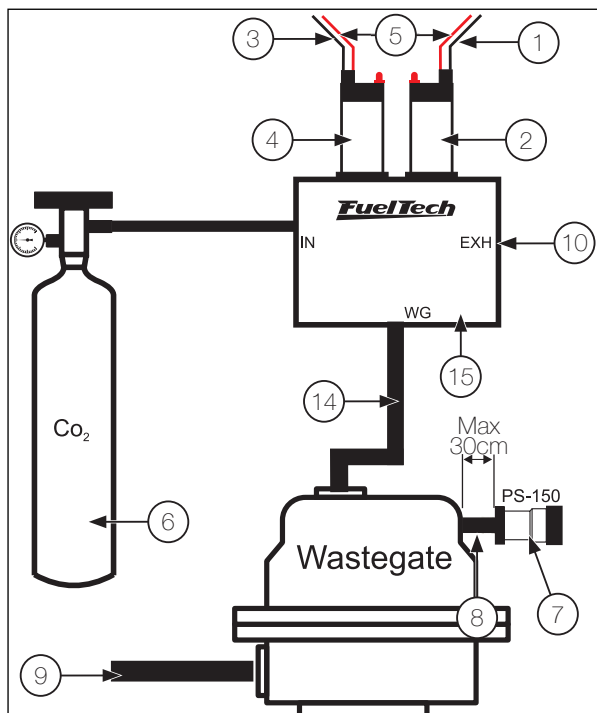

Diagram with FT dual valve block



WARNING

The boostcontroller test (when set as time based after 2-step) will only work with the engine turned off.

To test this feature with the engine running, a valid launch is required (when with the 2-step activated the engine hits TPS higher than 50% or the 2-step rev limiter).

FTManager setting

Through FTManager you can make all settings required for the operation the BoostController.

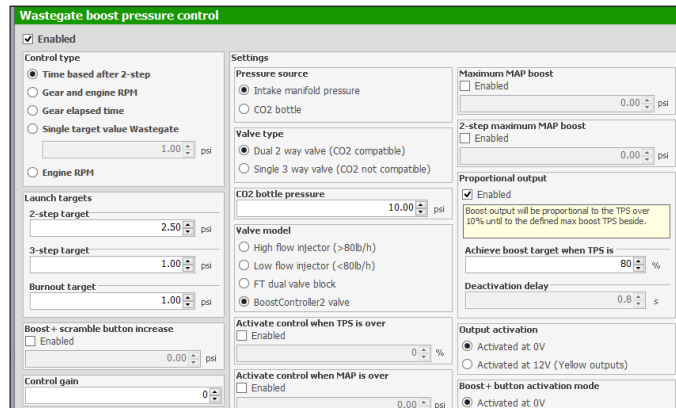

IMPORTANT

Use a PS150 pressure sensor connected to any white input. Setup as "Wastegate pressure".

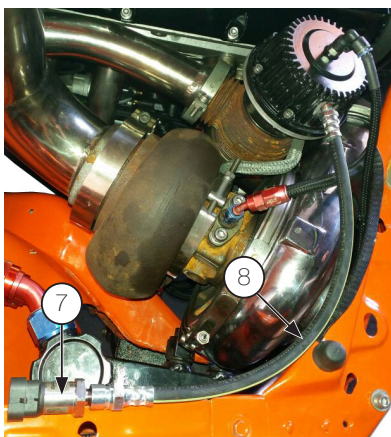

NOTE

The pressure sensor (7) must be connected to the top of the wastegate with a hose (8) with a maximum length of 1ft. It prevents damage to the pressure sensor caused by vibration.



IMPORTANT

- The pressure sensor must be installed on an exclusive line, and not shared with any other connection, to avoid reading errors.
- For the correct operation of the system, use only FuelTech PS sensors line: PS-150, PS-300, etc.

Set the input for the pressure sensor as PS-10B, PS-20B, PS-150 and PS-300 or BoostController2 MAP. In FTManager access the menu "sensors and calibration/inputs".

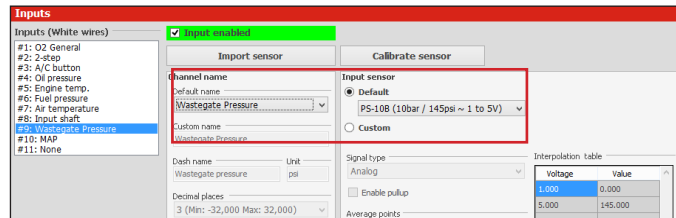

Set the outputs of the increase and decrease solenoid valves.

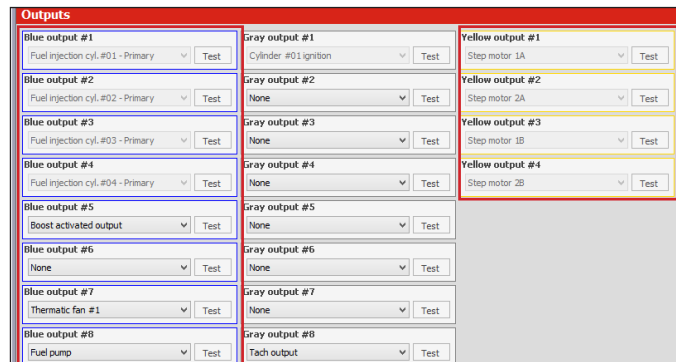

NOTE

It is recommended to use the yellow or blue outputs for connecting the solenoids.



IMPORTANT

Avoid using different color outputs for solenoids. Use two yellow outputs or two blue outputs.

In datalogger you can configure the channels for monitoring BoostController pressure.

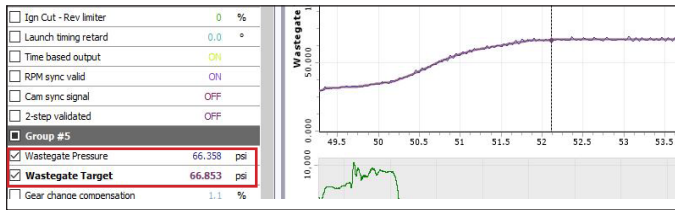

FT Input setting

In the "Sensors and calibration" menu select the "Wastegate pressure", after this set the associated input and the sensor type used.

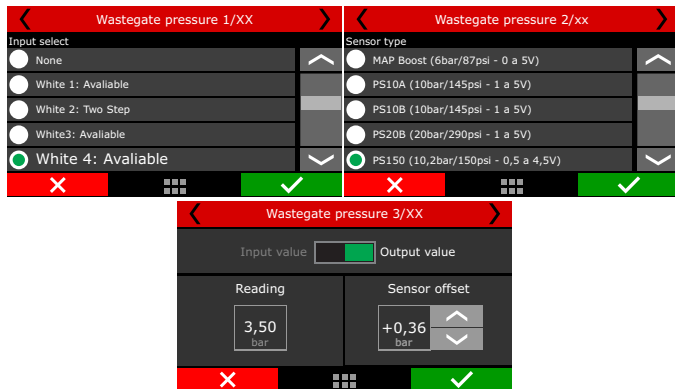

FT setting

In this menu, you can setup the BoostController basic functions.



Basic: You can access all control settings through the FT screen.

Control gain: Adjust the control gain according to the valve response. If it is taking to achieve the target it is necessary to increase the gain, if it overshoots the target it is necessary to reduce this value.

Advanced (PC): Some settings are available only in FTManager software.



Pressure source: When configuring your boost controller, it is necessary to inform the ECU where your pressure will be sourced from; intake manifold, or CO2 bottle.

When using a bottle, an industrial pressure regulator is required, limiting the line pressure according to the desired configuration. Two manometers must be used, one before the regulator indicating the pressure in the bottle and the other after the regulator showing pressure in the line.

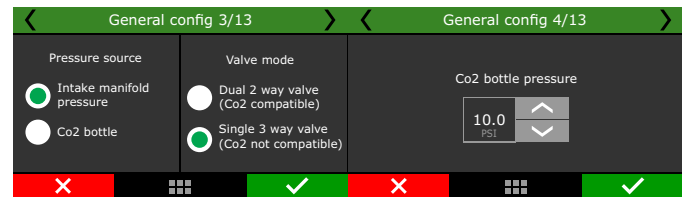

Valve model: You can choose which valve type will be used, high or low flow injectors, FuelTech 2 valve block or BoostController2 solenoid. You can set a minimum value for BoostController activation by TPS and MAP.

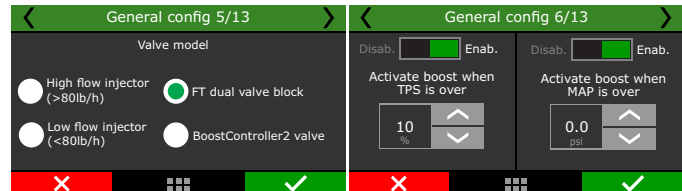

Proportional output: from 10% TPS the output is proportional to the map. The programmed pressure is reached when the TPS reaches the value set.

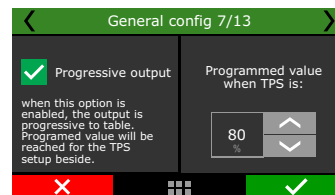

MAP maximum pressure and MAP maximum pressure on 2-step: Allow to set a MAP maximum pressure during 2-step and out of the 2-step. This function will not adjust the MAP pressure according to a target and will make the pressure bounces around the target. This maximum pressure must be used only as a safety feature to prevent overboost.

Output activation: the output can be triggered at 0V or 12V

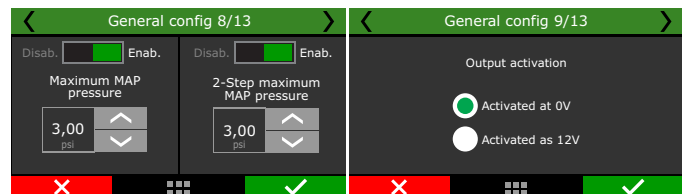

Boost+ button: Increases boost pressure while is switched on.

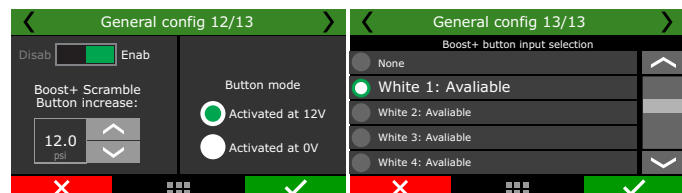

Launch targets

Defines the target pressure at the top of the valve in 2-step, 3-step and burnout mode.

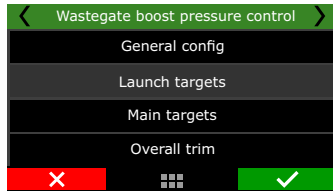

2-step target: Set the target pressure during 2-step.

3-step target: Set the target pressure during 3-step.

Burnout target: Set the target pressure during burnout mode.

Anti-lag / Pops & Bangs / Engine Brake target: Configure the boostcontroller target when under these conditions.

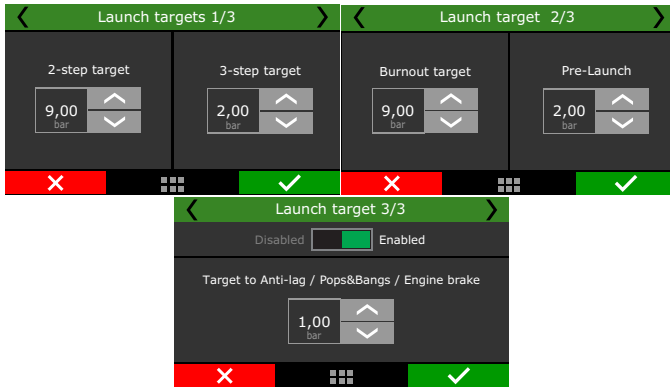

Boost maps

In this function you can set modes of boost maps by time after 2-step (single-stage), by gear and engine RPM (a stage for each gear), by gear elapsed time (a stage by each gear) and single value target.



By time after 2-step: Allows a detailed ramp up to 32 time points. The intermediate values are interpolated.

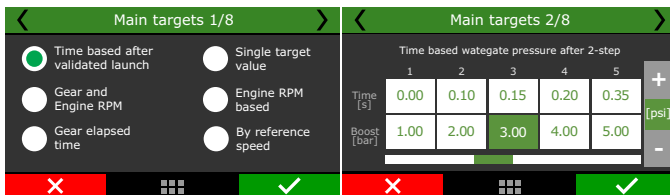

By gear and engine RPM: set up a stage for each gear, with up to 8 points per engine RPM. It is necessary that the gear change detection function is enabled. It does not depend on 2-step.

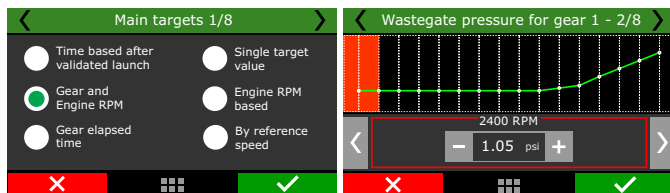

By gear elapsed time: Set up a stage for each gear, with up to 8 time points after the shift.

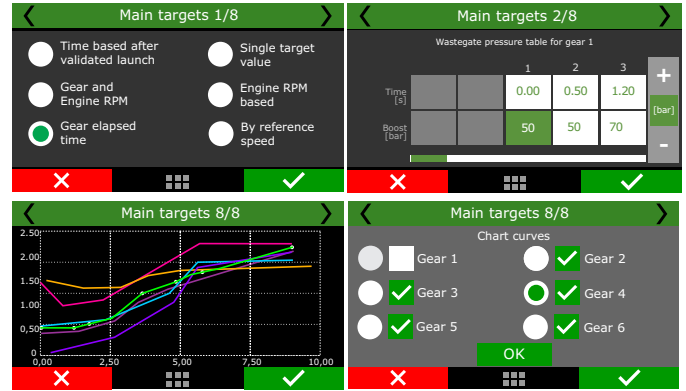

Single target value: Sets a fixed pressure for BoostController. The wastegate valve will always work this pressure.

This mode is recommended for dynamometer tests.

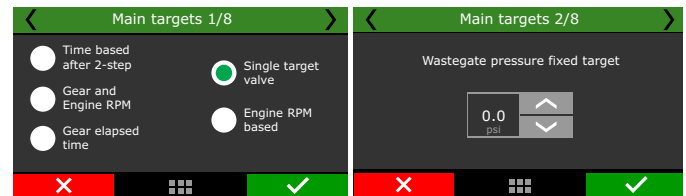

By engine RPM: Adjust the wastegate pressure according to the engine RPM only.

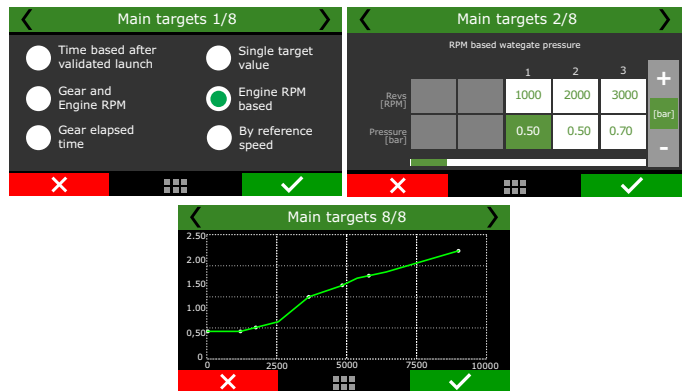

By reference speed: Adjust the wastegate pressure according to reference speed.

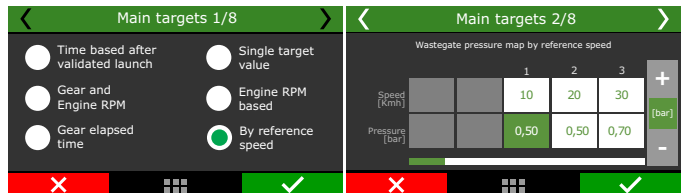

Overall Trim:

It is possible to do a target pressure overall trim.
Target pressure overall trim is available to any kind of boost control type.



When boost control type is selected by gear, the overall trim can be individually applied.



NOTE
Is mandatory to have gear change detection activated to use any kind of gear control.)

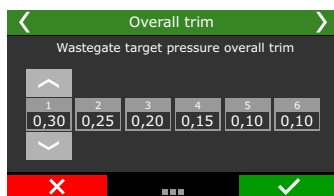

19.18 Power shift (GearController FT550 / LITE and FT600)

This feature allows gear shifting in manual transmission gearboxes (sequential or not) without the use of the clutch (flat shifts).



NOTE
This feature can only be used on dog engagement equipped gearboxes. Synchronized gearboxes may be severely damaged when trying to shift gears without using the clutch, even if used with the power shift feature.

When this function is activated, the white inputs number 19 and 20 will be automatically setup as gear shifter force sensor.

It is possible to setup the ignition timing during the cut in two different ways: using the main timing table or using a fixed timing.

Main table: timing on gear shifts will use the values set in the main timing table.

Fixed timing: adjust the ignition timing according to the selected gear.

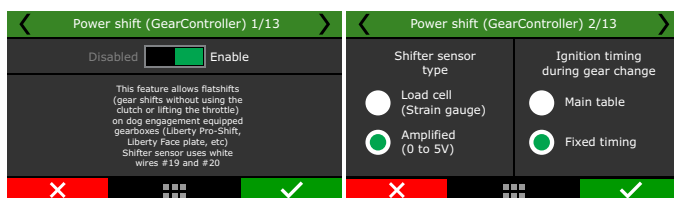

Cut duration: the cut duration configuration is adjusted in ms and the values are configurable by gear.

The cut duration is used to disengage the current gear, therefore, the next gear engagement is done by the mechanical system of the gearbox.

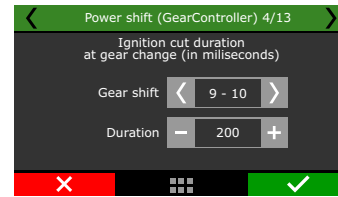

Fixed timing: this setting fixes the ignition timing during the gear shifts. It is configurable by gear.

Set the % of the ignition cut for each gear.

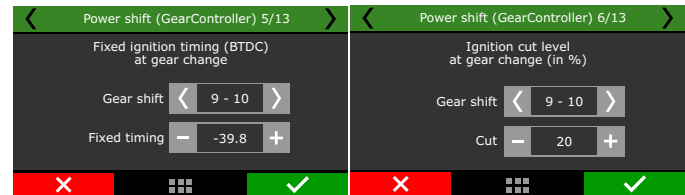

When the gearbox has an analog gear position sensor, the powershift feature has the option to interrupt the cut as soon as the new gear is detected. This helps to save the gear engagements and ensures that the power is only released after the full engagement of the next gear.

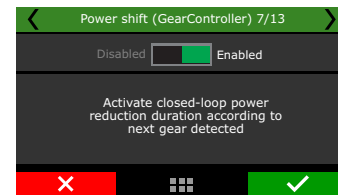

Set the minimum TPS for the gear cut and lock time between gears after launch.

Select which cut will be used, choosing between ignition only or ignition and injection.

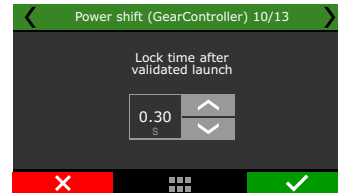
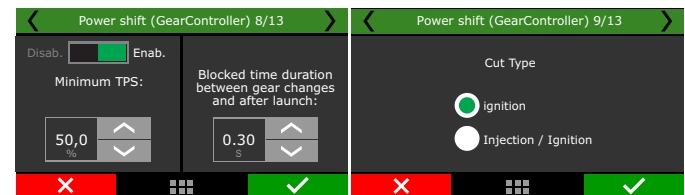

Shifter type: select the shifter type - H/Inline pattern or sequential shifter. Also select if your shifter is normal or inverted.

When forcing the shifter, check the voltage reading in the FT diagnostic panel or in the log, while shifting gears.

- If the voltage goes from 2.5V towards 5V, select the Normal shifter type.
- If the voltage goes from 2.5V towards 0V, select Inverted as shifter type.

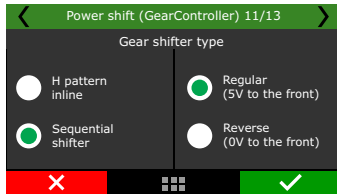

The shifter voltage cut level is used to disengage the current gear, therefore, the force to the back means the voltage to disengage odd gears (1st, 3rd, 5th) and force to the front refers to the cut to disengage even gears (2nd, 4th).

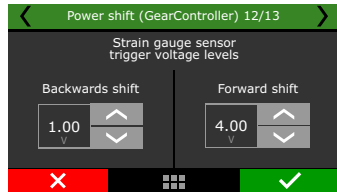

With the car stopped, push the shifter to the front and check the voltage read in the FT diagnostic panel. The recommended value is between 4 and 4.5V (or 0.5 and 1V - inverted transmission).

If the lever signal reaches 0V or 5V easily, lower the sensitivity gain in order to keep it below 5V and above 0V, the shifter voltages must never hit these limits.

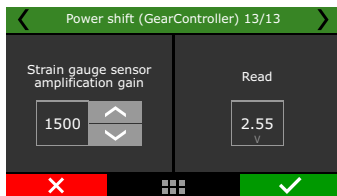

Power shift lever connection diagram (FT600)

- 1- Connect the blue wire from the shifter to the input #19 - white wire (pin 33 - FT600's B connector);
- 2- Connect the orange wire from the shifter to the input #20 - white wire (pin 34 - FT600's B connector);
- 3- Connect the two white wires from the shifter to the green/black wire from the ECU - sensors ground (pin29 FT600's B connector);

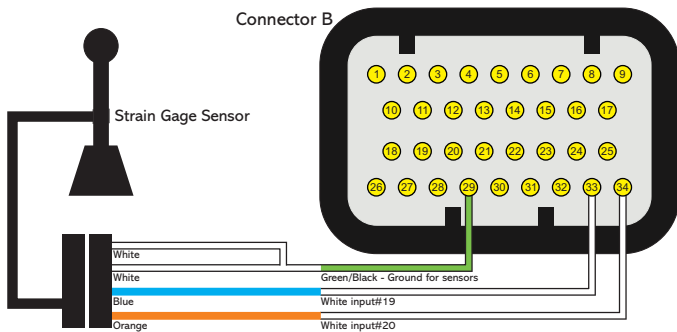

Power shift lever connection diagram (FT550 / LITE)

- 1 - Connect the blue wire from the shifter to the input #13 - White wire (pin 18 FT550's B connector);
- 2 - Connect the orange wire from the shifter to the input #14 - White wire (pin 19 FT550's B connector);
- 3 - Connect the two whites from the shifter to the green/black from the ECU - sensors ground (pin 26 FT550's B connector);

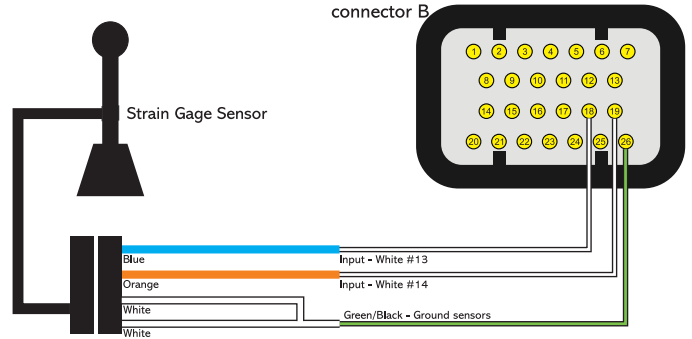

GearController reset for sequential change

The reset logic is based on the user set value.

Sequential / Normal shifter (5V forward)

The gear shift reset will occur when the lever voltage is greater than the voltage calculated by the equation below.

$$\text{Reset voltage (V)} = 2,5 - ((2,5 - \text{tensile strength back}) \times 0,3)$$

Sequential / inverted shifter (0V forward)

The gear shift reset will occur when the lever voltage is less than the voltage calculated by the equation below.

$$\text{Reset voltage (V)} = 2,5 + ((\text{tensile strength back} - 2,5) \times 0,3)$$

19.19 Start Button

This function allows the control of the vehicle's starter motor through an output (blue, gray or yellow wires) and an input (white wire) or through the FT screen.

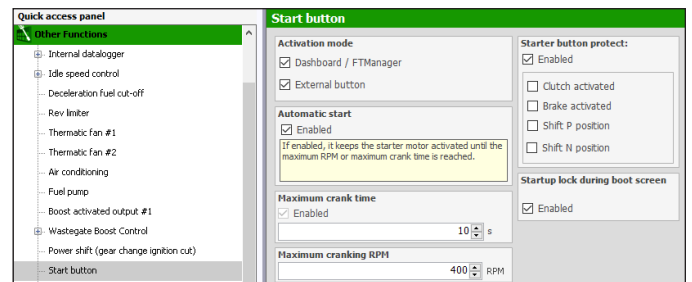

Select whether you want to start the engine through the FT LCD screen (must setup the "Start Button" item on the FT dashboard" or through an external switch

If Dashboard is chosen the starter motor remains engaged while the button is being pressed and until the engine RPM goes above the "RPM for engine start" (set in the Engine Setup menu". As soon as the engine is running, the function of the button on the dashboard is now changed to turn the engine off when pressed (by cutting fuel and spark).

When external switch is selected.

Select whether the input is activated when it receives 0V (ground) 12V. The output that activates the starter relay can be programmed whether to send 0V or 12V when activated.

Automatic Start: When this option is selected, you no longer need to hold down on the start button, just one touch and the ECU will keep activating the starter automatically, however some precautions need taken, such as those described below.

- Set the Maximum RPM for cranking: when detecting an RPM above the configured value, the button is turned off.
- Maximum cranking time: Adjust the time limit within which the starter will start engine.
- Check that the car is not in gear.

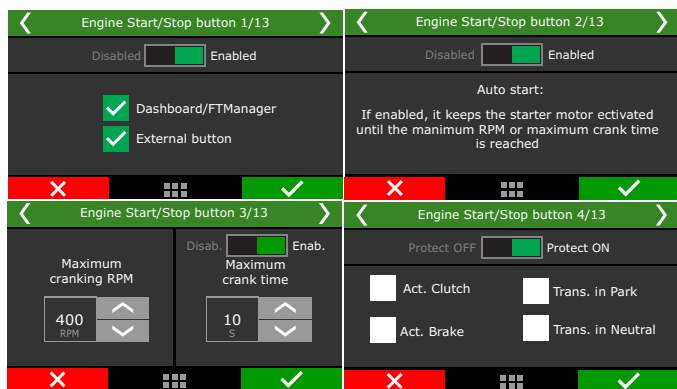

Select all the safety protections for the engine start button, they will prevent the engine from cranking if the conditions are not met.

Define whether there will be a startup lock during the startup screen. This lock is necessary for use on watercraft, as the button that turns on the ECU is the same one that starts it.

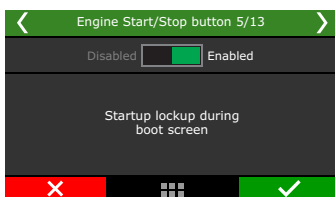

Starter button for PWC

For PWC it is necessary to configure three inputs for the start button, one to start the pwc, one to start the engine and one to stop.

Select an output to activate the engine starter relay.

Select the input to the start button.

Define which is the activation signal to the input button and to the output if 12V or 0V.

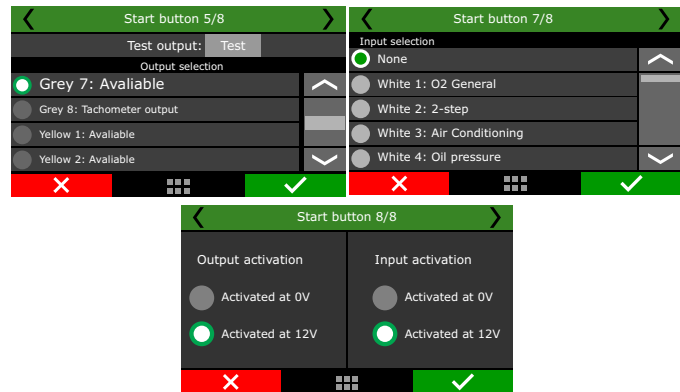

19.20 RPM activated output

This function allows enable output when the RPM is above a determined value.

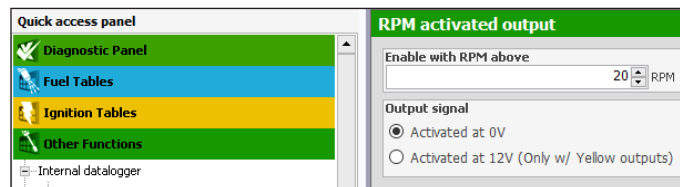

19.21 Pit limit

This feature limits the speed to a set value, it can be activated through a dashboard button, an external button or an external switch.

External button: will keep the function activated for as long as it's pressed, deactivating when the button is released.

External switch: When pressed, it'll keep the function activated until it's pressed again, the same applies for the dashboard button. Both can be set up using a white wire or via CAN 2.0.

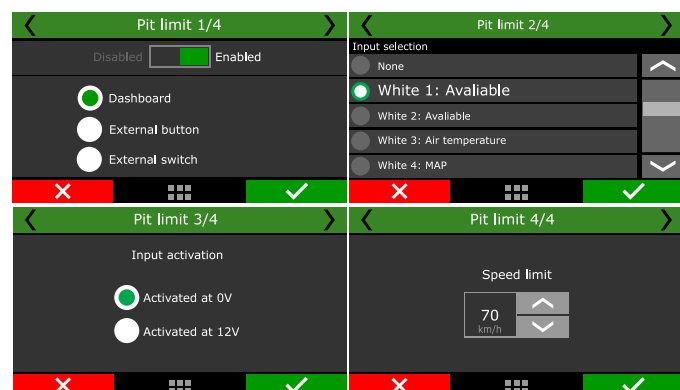

19.22 Active traction control

This function actively controls the vehicle traction by changing ignition timing and the electronic throttle to try to obtain the best possible traction on various track conditions.



NOTE

To use this feature, the vehicle must have at least 2 wheel speed sensors with speed differences between them.

Settings

On this menu it's possible to set up all the options regarding the traction control.

Always active: The control is always active and will function whenever the parameters defined in the settings are met.

Only with validated launch: the control will only function after a valid launch (when the settings for 2step are reached before launch)

Dashboard: Activates the control through a button on the dashboard.

External switch: Activates the control though an external on/off switch.

External button: Activates the control while the button is pressed, deactivates when released.

If External button or External switch is selected, a white wire or CAN (Switchpanel-8 or OEM) must be set up.

After one of the activation options are selected, it's possible to choose whether the control will be enabled or disabled when the ECU starts. Next the minimum RPM must be set, this is the lowest RPM the control will allow the engine to drop to, and below this RPM the control will not actuate.

The same principle is applied to the settings of minimum and maximum speed (of the reference wheel), the control will not actuate below the minimum speed or above the maximum speed.

There's also the possibility to deactivate the control right after a gear change is detected, allowing for some wheel slip during this set amount of time.

If necessary, configure an event status output to show when traction control is active.

Table selection mode

Here it's possible to set the quantity of tables and how to select them.

Dashboard: When selected, a button must be set up at "dashboard setup" menu, this button will switch between tables.

By gear: When selected, the tables will be assigned according to the current gear. That being: first gear > table-1, second gear > table-2, and so on.

External analog selector: When selected, it's possible to use an external multi-position selector by setting the voltage level for each table.

Target tables

The tables can be set up three different ways.

Time based after validated launch: creates a 6x16 TPS% by Time after validated launch, target slip table.

Engine RPM based: creates a 4x8 TPS% by engine RPM target slip table.

Vehicle speed based: creates a 6x16 TPS% by wheel speed target slip table.

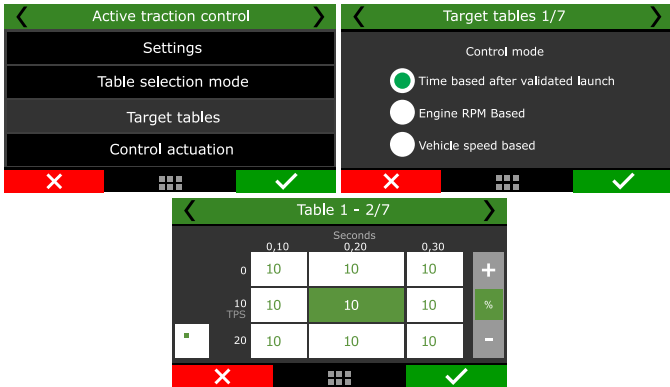

Control actuation

In this menu it's possible to set up how the traction control will actuate on the vehicle.

The reaction level can be set between 1 (less aggressive) and 10 (very aggressive), and it dictates how the traction control will actuate.

Initial slip is the minimum wheel slip allowed, this is needed when the vehicle launches to get the car moving easily.

The strategy of the traction control to maintain the slip target is to retard the timing first, and if the slip is still increasing it will start to cut the ignition too.

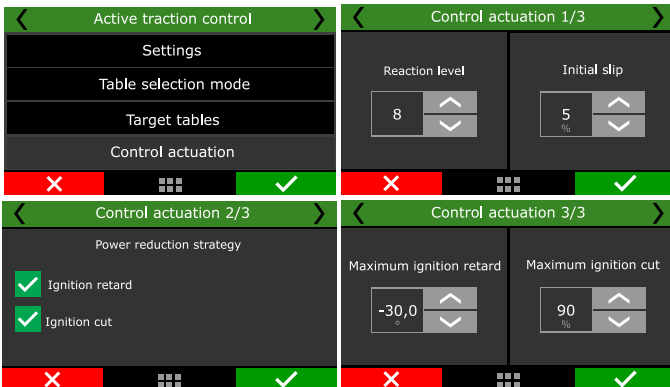

Configure what Egate's mode of operation will be and also the pressure and target for the slip.



19.23 Generic Outputs

In this menu it's possible to set up to 8 different outputs for various uses like activating exhaust diverts, turn off alternators during drag races, and many others that require datalogging. These outputs must be activated by either a white input or via CAN with the SwitchPanel-8.

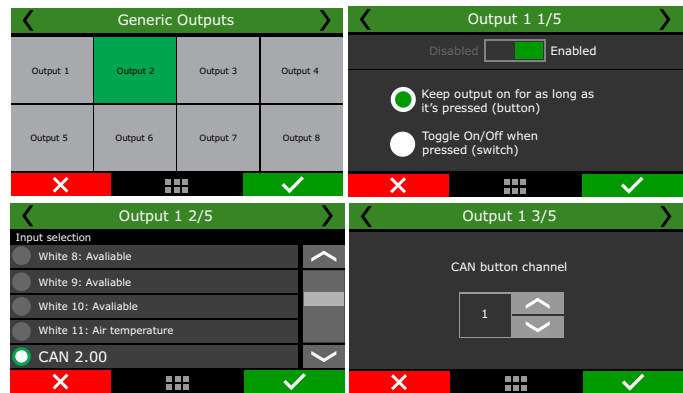

19.24 Flex Fuel

General Settings

This feature allows the ECU to apply compensations on fuel, ignition timing and BoostController, based on ethanol content reading by using a Flex Fuel Sensor on the fuel lines.

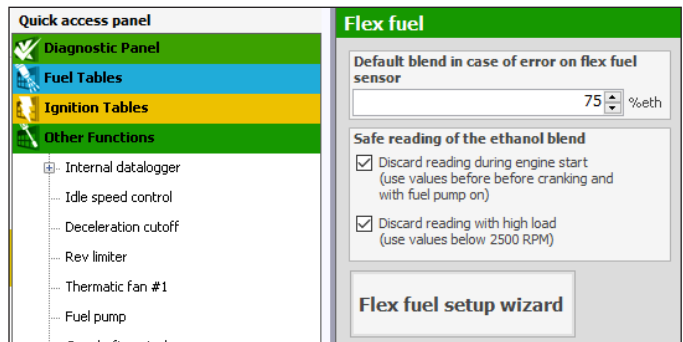

If the sensor is disconnected or there's a malfunction, the ECU will use the compensations based on this blend.

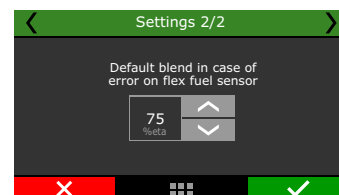

Main fuel injection compensation

The main fuel injection table works real time over the main fuel map, compensating the fuel need according to the ethanol percentage in the tank.

One of the axis on the table is ethanol percentage, the other is MAP or TPS (depend of main fuel table setting) and the amount of fuel to be added or subtracted must be placed in the table cells.

For a 100% ethanol mapped engine, as ethanol percentage decrease, less amount of fuel is required, so the values in the table will normally be negative.

For a 100% gasoline mapped engine, as the ethanol percentage increases, more amount of fuel is needed, so the values in the table will be positive.

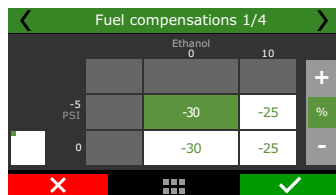

Prime pulse and engine start: Fuel percentage compensation table for prime pulse and engine start according to the percentage of ethanol used.

Based on a ethanol tune, ethanol percentage decrease requires negative compensation to start the engine.

For gasoline based map, raising the ethanol level requires positive compensation to start the engine.

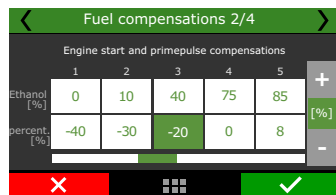

Acceleration fuel enrichment: Usually, ethanol engines require more acceleration fuel enrichment than gasoline tuned engines.

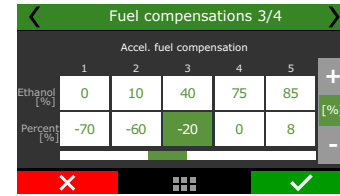

O2 closed loop target: Based on ethanol percentage and MAP or TPS (depending of main fuel table settings). All the values set on the table will be added or subtracted to the main closed loop table and interpolated according to engine RPM.

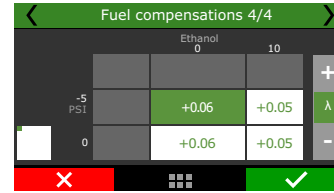

Ignition compensation

It is possible to apply ignition compensations depending on ethanol percentage, the table is also related to MAP or TPS reading. The values set in the table are in °BTDC and are added to the ignition map, interpolating MAP or TPS with engine rpm to obtain the final value.

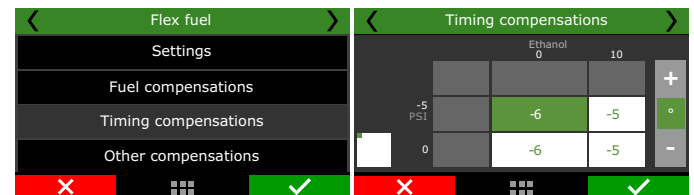

Other compensations

When the BoostController feature is enabled, it is possible to change pressure targets in the wastegate according to ethanol percentage, adjusting engine power to the fuel used. The values in the table are added or removed in BoostController function maps, even in cases of different pressures per gear, 2-step, 3-step, Burnout or Pre-Start target pressures.

When turbo pressure is controlled by generic duty cycle output, ethanol percentage can also change the pulse frequency that opens / closes the wastegate, adjusting the engine power to the fuel used. The value entered in the table is added to the original PWM curve of the map.

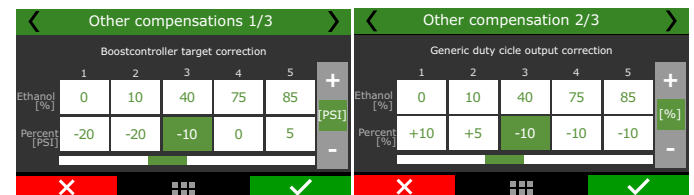

19.25 Blip / Heel and toe

The blip/heel and toe feature quickly opens or closes the throttle when shifting gears.

The feature adds a percentage of opening in the throttle channel, so if you have the TPS at 20% and blip configured to add 60%, the final opening will be 80%. And, even if some function is limiting the opening of the throttle (custom pedal/throttle curves or maximum electronic butterfly opening), the blip function will still achieve its target, even if it exceeds the maximum value configured in these functions.

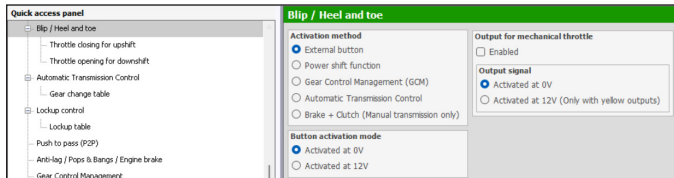

Activation method

- External button:** Uses a white input to receive a blip signal;
- Power Shift:** Applies blip with the Power Shift function;
- FTCAN 2.0:** Receives blip signal from any FuelTech equipment connected to the CAN network;
- Gear Control Management - GCM function:** Applies blip when with GCM function;
- Automatic transmission control:** Applies blip when shifting through the automatic transmission control;
- Brake + Clutch:** Applies the blip when the brake and clutch pedal inputs are activated simultaneously. It is suitable for cars with standard manual transmissions;

Button activation mode: Choose whether the function will be activated by 0V (ground) or positive (12V)

Output for mechanical throttle: Enables a pulse output to open a mechanical throttle through an actuator/solenoid that pulls the throttle cable.

Output Signal: Choose whether the function will be activated by 0V (ground) or positive (12V).

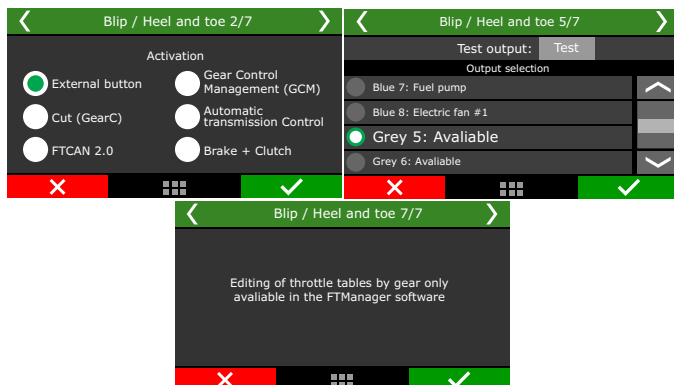

WARNING

This function was developed to work in conjunction with an external sequential gearbox control module with electrical or pneumatic drive that has a specific output for controlling the “blip”.

The Throttle opening and closing tables are only available in the FTManager software.

Configure the opening and closing time and percentage for each throttle position and gear.

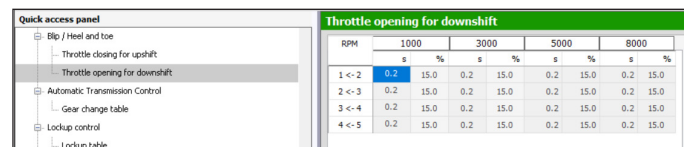
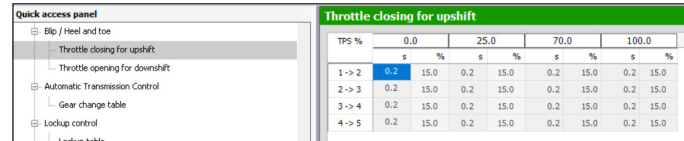

19.26 Variable Camshaft (VVT)

This feature allows independent intake and exhaust camshaft angle control according to separate target tables for both of them.

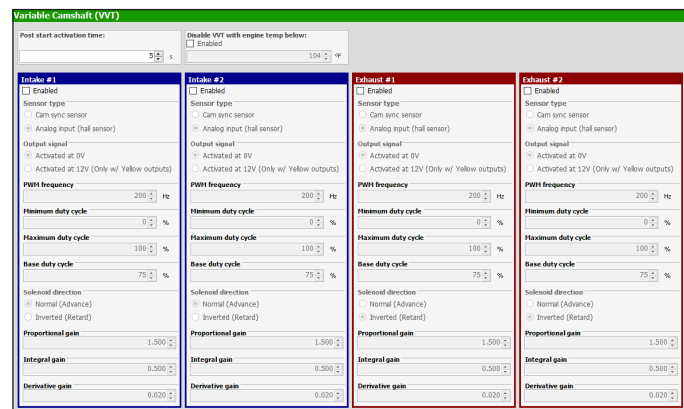

IMPORTANT

Check the physical limitations of your variable camshaft. In case this feature is improperly used, it may cause irreversible damage to the engine (valves hitting each other or the piston, specially when using aftermarket cams).



WARNING

We recommend using yellow outputs for VVT (FT500, FT550 and FT600). These outputs do not need any modifications or add-ons (protection diodes) on the harness. For FT450, blue output #5 has this protection diode built-in. Other blue outputs require adding a protection diode according to the diagram.



NOTE
Recommended diode: 1N5400, 1N5401, 1N5402, 1N5404, 1N5406, 1N5407 or 1N5408.



IMPORTANT
Gray outputs are **NOT** recommended for the VVT control.

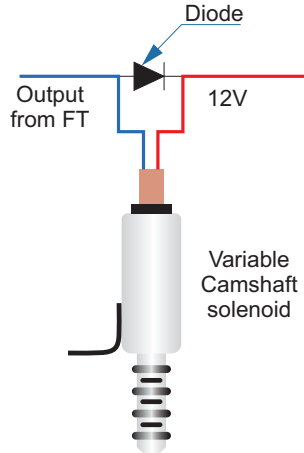

MAP (psi)	RPM (rpm)						
	2000	4000	5500	6000	6500	7000	7500
87.02	2.0	1.9	1.9	1.9	1.9	1.8	1.8
72.52	3.9	3.7	3.6	3.5	3.5	3.4	3.4

Intake target 2/3			Exhaust target 3/3		
RPM 400 1000			RPM 400 1000		
-5 PSI	20	20	-5 PSI	20	20
0	20	20	0	20	20

Camshaft sensors

Here the parameters for all the camshaft sensors to be controlled are input.



NOTE
The screens shown here are for intake 1. The procedure is the same for all other camshafts.

General configurations

Select how many variable camshafts are going to be used, it's possible to use up to four, 2 intake and 2 exhaust.

Variable camshaft (VVT)		General configurations 1/3	
general configurations			
Disabled <input type="checkbox"/>		Enabled <input checked="" type="checkbox"/>	
Intake 1	Exhaust 1	<input checked="" type="checkbox"/> Intake 1	<input checked="" type="checkbox"/> Exhaust 1
Intake 2	Exhaust 2	<input checked="" type="checkbox"/> Intake 2	<input checked="" type="checkbox"/> Exhaust 2

Time after engine start for VVT activation: configures a blocking time to activate the VVT, this time aims to facilitate the engine start.
Block VVT with motor temp below: limits VVT performance for a minimum activation temperature.

Variable camshaft (VVT) 2/10	
Post start activation time: 5	Disable VVT with engine temp below: 40 °C

Intake #2	Exhaust #1
Sensor position angle: 0.0 °BTDC	Sensor position angle: 0.0 °BTDC
Cam wheel type: Single tooth	Cam wheel type: Single tooth
Sensor edge: [dropdown]	Sensor edge: [dropdown]
Window filter detection angle: 0 °	Window filter detection angle: 0 °
Multiple teeth: <input checked="" type="radio"/>	Multiple teeth: <input checked="" type="radio"/>
Teeth tolerance: 10.0 %	Teeth tolerance: 10.0 %
Teeth table	Teeth table
Wheel decoder	Wheel decoder

Variable camshaft (VVT)	
General configurations	
Intake 1	Exhaust 1
Intake 2	Exhaust 2

Fill out the target tables for intake or/and exhaust. The values are shown in degrees, in relation to cam sync position sensor

Example: If the sensor is at 45°, and there's a value of 10° in the table, the camshaft will be mode to 55°.

MAP (psi)	RPM (rpm)									
	2000	4000	5500	6000	6500	7000	7500	8000	8500	9000
87.02	0.0	0.2	0.4	0.4	0.5	0.5	0.6	0.6	0.7	0.7
72.52	2.1	2.2	2.2	2.2	2.2	2.2	2.2	2.2	2.2	2.2
58.02	4.3	4.2	4.0	4.0	4.0	3.9	3.9	3.9	3.8	3.8

Sensor position angle: There are two options to get the signal: using a cam sync sensor on it's dedicated input or a hall effect sensor on one of the Analog inputs.

Intake 1 1/6	
Position sensor	
<input checked="" type="radio"/> Cam sync sensor	<input type="radio"/> Analog input (Hall effect sensor)

Select an output that is going to drive the actuator solenoid for the camshaft and how it's going to activate, then select its PWM frequency.

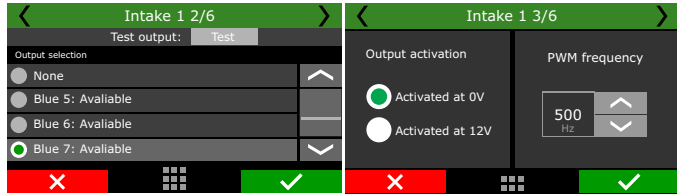

Insert the minimum and maximum duty cycles. Adjust the base duty cycle percentage and its direction of actuation.

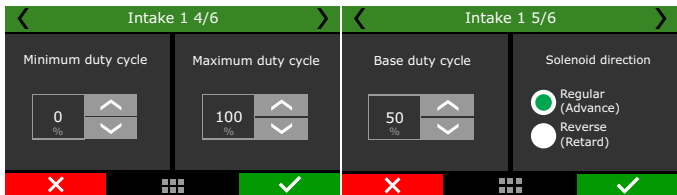

In the last screen the Proportional, Integral and Derivative values are set.

Proportional gain: How fast the control tries to reach the target.
Integral gain: Is the accumulated error over time, that should have been corrected, from the proportional gain in trying to reach the target.
Derivative gain: Smooths out the approach and overshoot control around the target.

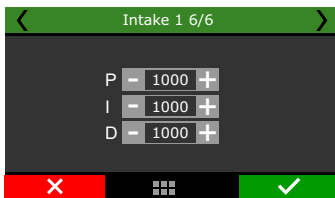

Analog input (Intake 1): Uses another cam sync sensor to manage camshaft position.



NOTE
 The screens shown here are for intake 1. The procedure is the same for all other camshafts.

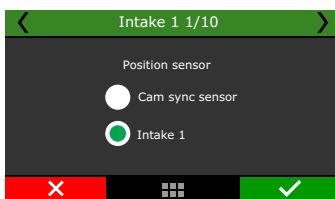

Cam wheel type

Single tooth: This option should be selected when there's only one tooth for reference.

Multiple teeth: This option should be selected when there are multiple teeth for reference. It's very important to inform the sensor position as this will be the reference for the target tables.

Example: If the sensor is installed at 100° and there's a 10° increment in the target table, the final angle will be 110°.

The detection window creates a range in degrees in which the ECU expects the signal, ignoring signals found outside of it.

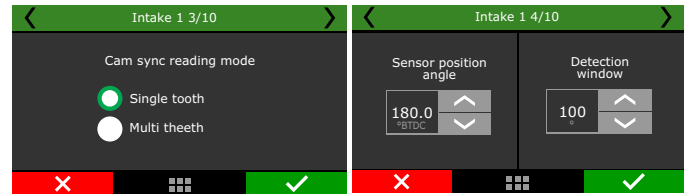

Wheel decoder

The decoder can be used either by just cranking or running the engine, it will automatically detect all teeth in cam sync wheel and draw the signal pattern, then one of the angles must be chosen as the sync reference.

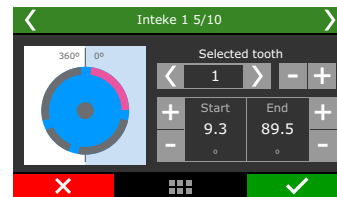
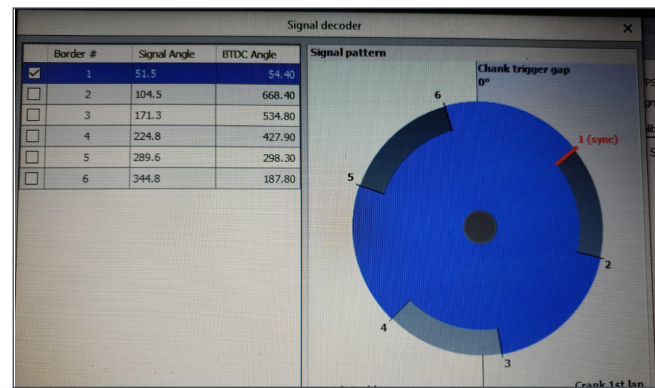

Default configuration for 2JZ WTi - Single tooth

Intake #1	
Sensor type	Cam sync sensor
Output signal	0V
PWM Freq	200 Hz
Minimum duty cycle	0%
Maximum duty cycle	100%
Base duty cycle	75%
Solenoid direction	Advance
Proportional gain	1.500
Integral gain	0.50000
Derivative gain	0.020
Camshaft sensors	
Sensor position angle	70.0 °BTDC
Sensor edge	Rising
Window filter detection angle	120°
Cam sync wheel	
Sensor edge	Rising
Window filter detection angle	120°

Default configuration for 2JZ WTi - Multiple teeth

Intake #1	
Sensor type	Cam sync sensor
Output signal	0V
PWM Freq	200 Hz
Minimum duty cycle	0%
Maximum duty cycle	100%
Base duty cycle	75%
Solenoid direction	Advance
Proportional gain	1.500
Integral gain	0.50000
Derivative gain	0.020
Camshaft sensors	
Sensor position angle	70.0 °BTDC
Sensor edge	Rising
Window filter detection angle	120°
Cam sync wheel	
Cam sync teeth tolerance	30%
Window filter detection angle	120°
Cam sync teeth table	Use Cam sync wheel decoder button

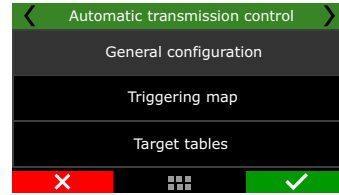

The first step is to select which strategy will be adopted to control the transmission when the vehicle is running.

Limit the number of gears: In this configuration, the transmission will shift gears only until the last gear selected.

For example: When "3" is selected in the shifter, the transmission will only perform gear shifts among 1st, 2nd and 3rd gears.

Hold actual gear: Holds the transmission at the gear selected in the shifter.

For example: When "3" is selected in the shifter, the transmission will only run in 3rd gear, not performing any gear shift.

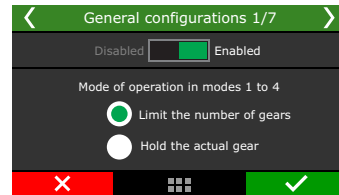

Configuration for the total oil line pressure during 2-step/Transbrake.

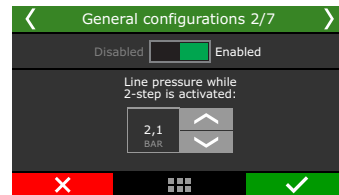

19.27 Automatic Transmission Control

This function enables the ECU to control automatic transmissions up to 10-speed gearboxes.

Based on speed maps and function settings, the ECU will automatically select the desired gear and it is able to interpret temperature, pressure and speed data from the original transmission sensors.



IMPORTANT
To use this feature and set it up properly, you need the electrical diagram of the transmission you want to control

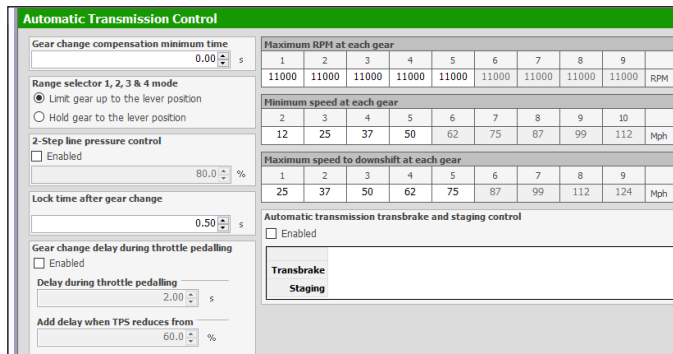

Sets the locking time between gear changes.

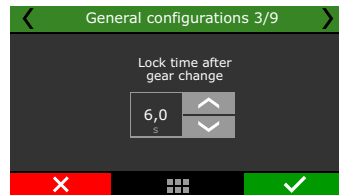

Sets the delay and the percentage of TPS when pedaling the accelerator, this prevents the transmission from shifting several gears when the accelerator is pedaled.

It is possible to activate the solenoids between gear changes, this configuration is necessary for the correct control of some gears.

General configurations

For a proper automatic transmission control it is necessary to set up which solenoids will be active for each gear and also the sensors that will feed the ECU with transmission oil pressure data.

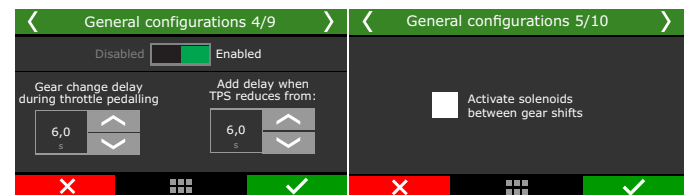

The next screen is dedicated to set up which solenoids will be activated.

These solenoids are responsible for engaging or disengaging the sets of each gear.



NOTE

This manual describes the configuration of solenoid 1. The emails must be configured following the same procedure.

Transmission pressure: Main solenoid that controls the transmission line pressure, responsible for maintaining or increasing the oil pressure when necessary.

Accumulator solenoid: Solenoid that controls the amount of oil sent to the accumulator, smoothing the gear changes.

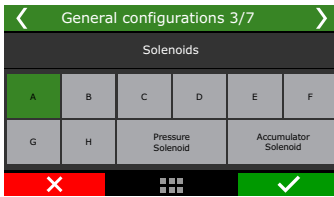

The first step is to enable the solenoid and set up the output for the control.



This configuration must be made for all gears available in the transmission, for both upshifts or for downshifts.

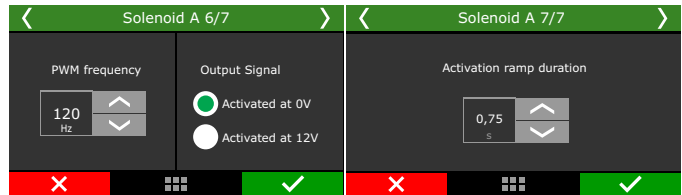

Triggering map (Gear)

This is where the automatic transmission programming is made. It is necessary to define which solenoids will be activated for each gear, for upshifts and downshifts.

Depending on the transmission model, it may be necessary to activate several solenoids simultaneously for certain gears. The number of solenoids may vary depending on transmission model.



IMPORTANT

This configuration is for gear changes and not Shifter position.

Quick access panel		Gear change trigger table							
Internal datalogger									
Idle speed control									
Deceleration cutoff									
Rev limiter									
Thermostatic fan #1									
Fuel pump									
Generic outputs									
Automatic gearbox control									
Solenoids									
Gear change trigger table									
Gear change table									
Gearbox line pressure table									
Line pressure by temperature compensation									
Gear change line pressure compensation									
Accumulator pressure table									
Lockup control									
Engin Race Features									
2-Step rev limiter									
Timing table for rev launch									
Time based compensations									
Wheels control									
Launch delay controls (delay box)									
Engine Settings									
Engine setup									
RPM signal									
Cam sync signal									
Ignition									

Upshift		Solenoid A	Solenoid B	Solenoid C	Solenoid D	Solenoid E	Solenoid F	Solenoid G	Solenoid H
P									
R									
N									
1									
2									
3									
4									
5									
6									
7									
8									
9									
10									

Downshift		Solenoid A	Solenoid B	Solenoid C	Solenoid D	Solenoid E	Solenoid F	Solenoid G	Solenoid H
P									
R									
N									
1									
2									
3									
4									
5									
6									
7									
8									

For example: To set up the 2nd gear, it is necessary to define which solenoids will be activated for up-shifting from 1st and for downshifting from 3rd.



NOTE

This configuration must be made for all gears available in the transmission, for both upshifts or for downshifts.



IMPORTANT

These triggering informations can usually be found on the electric and hydraulic diagrams of the transmission



NOTE

On the majority of transmissions, both tables can be the same.

Triggering map 2/14		Triggering map 3/14	
Configuration in P		Configuration in R	
Solenoids		Solenoids	
Upshift		Upshift	
Downshift		Downshift	
Triggering map 4/14		Triggering map 5/14	
Configuration in N		Configuration in 1	
Solenoids		Solenoids	
Upshift		Upshift	
Downshift		Downshift	

Triggering map (Transbrake / Staging)

This configuration creates a map for the vehicle when it's in Transbrake/ Staging mode, commonly used in drag racing. To activate this map, it is necessary to set up the table directly in the automatic transmission control function.

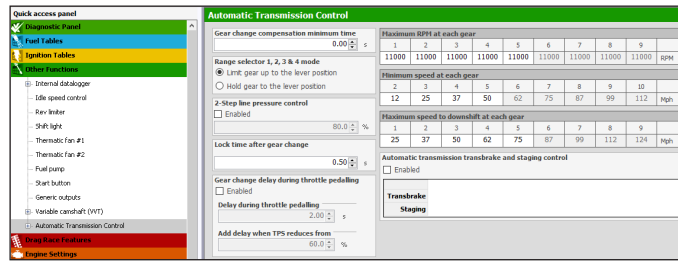

The setup procedure is the same as the one described for the gears. You just have to check the solenoids that will be activated for each condition.

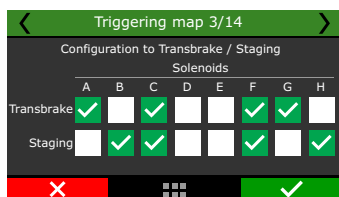

Tables

These tables will define the behavior in each gear and the changes between them. The main table is based on throttle position and the desired speed for each gear shift.

Maximum RPM in each gear: The maximum value allowed in each gear before shifting.



Minimum speed in each gear: Minimum speed that the ECU will hold the current engaged gear or deny a upshift.



Deny downshifts above speed: Maximum speed that the ECU will deny a downshift, avoiding drive-train and mechanical failures.



This is the main table for the gear shift operation. You must set the speed according to throttle position for all gear shifts and the ramps built for each shift schedule will define the values for each upshift and downshift. It is recommended to always set the downshift values lower than the upshifts.



Gearbox line pressure: The transmission oil pressure will be given according to the percentage set up in this table. The pressure won't necessarily increase as the percentage increases, depending on the transmission electrical system.

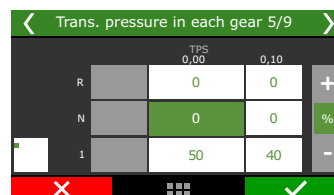
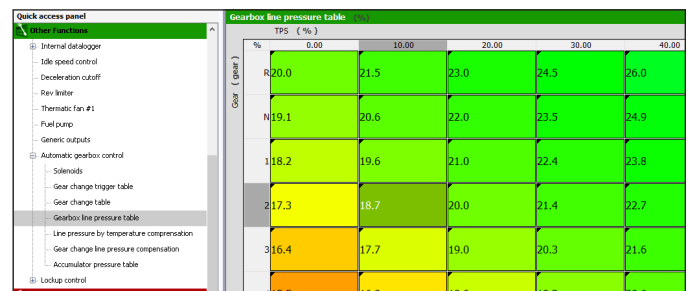

Line pressure compensation: This table allows the easy percent addition or reduction of oil pressure over the main table.

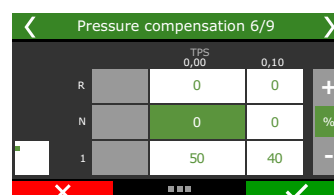
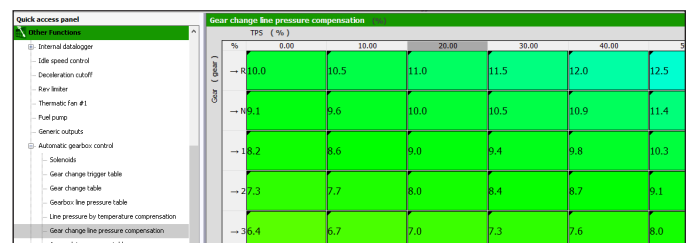

Line pressure by temperature compensation: This table allows the ECU to make percent compensations for oil pressure according to the oil temperature, helping the transmission to reach its operating temperature quickly.

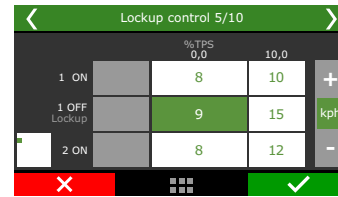
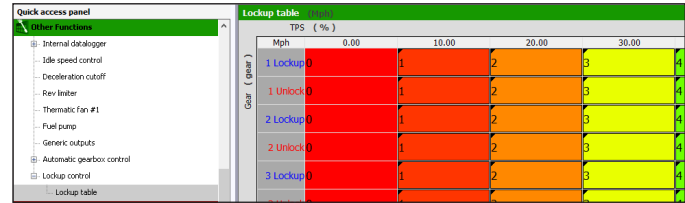
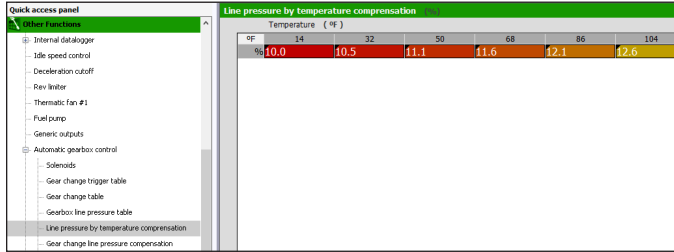

It is also necessary to setup the Lockup activation and deactivation ramps, so the system can operate smoothly.

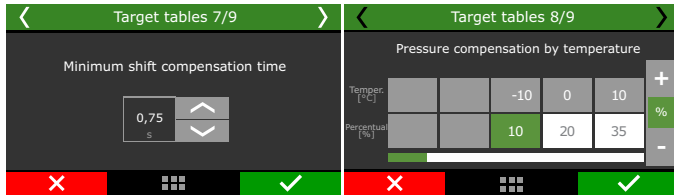
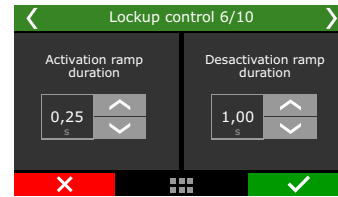

19.28 Lockup Control

This function allows the ECU to manage the slip percentage of the torque converter in automatic transmissions. To use this function it is necessary to set up the solenoid in a blue, gray or yellow output and adjust its frequency.

After the table is set up, it is necessary to adjust some Lockup control parameters, such as:

Lower gear: That is the lowest gear in which the torque converter will operate.

Temperatures: This option defines the maximum and minimum engine temperatures that will allow the torque converter to operate.

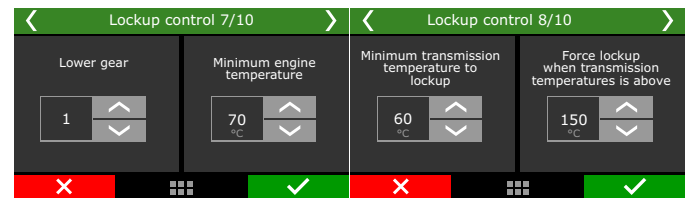
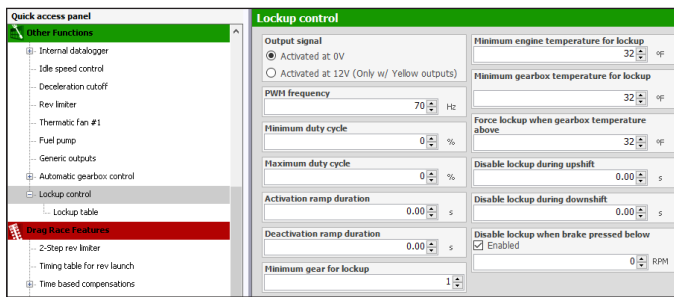

This last setting is applied for Lockup deactivation in conditions as manual gear shifting (paddle shifter) or when the brakes are applied below a certain RPM value.

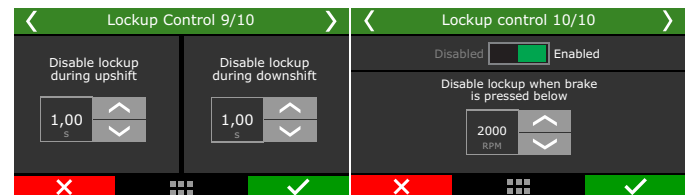

The next step is to adjust the solenoid operating range.

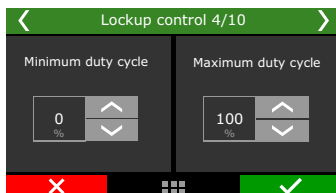

In this table you can set the speed and throttle position in which the Lockup will be activated/deactivated. The Lockup will be activated when the speed is higher than the value set and deactivated when the value is lower.

19.29 Push to pass (P2P)

This function allows to have 2 different maximum throttle opening in the same map, using a button or switch to change throttle maximum percentage.

To configure this function, go to menu "Engine settings / Pedal/ Throttle". If you want to use this feature, setup a maximum throttle opening lower than 100%.

Example: some road racing cars have a power limit that is controlled by the amount of throttle opening, and during some parts of the race the driver is allowed to use 100% of throttle.



NOTE

This function is only available with drive by wire control (electronic throttle control).

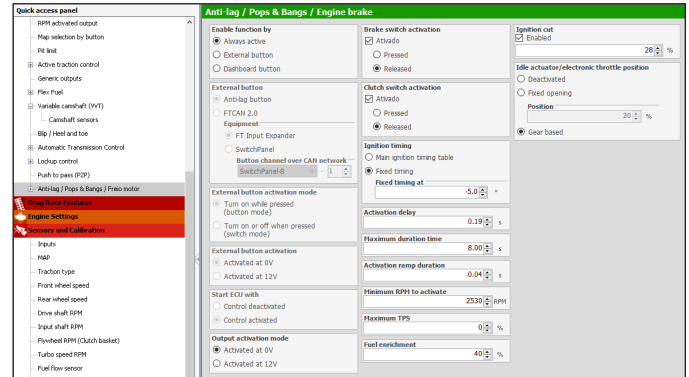
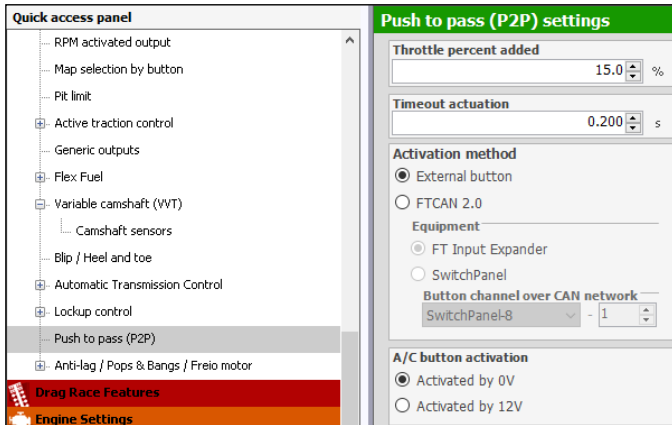

Configurations

There are 3 different options to enable this function:

- Always enabled
- Dashboard button
- External button

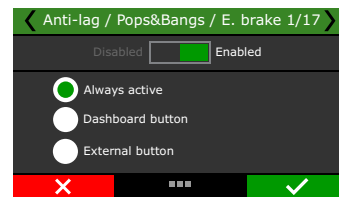

Throttle percent added: Sets the percentage to be added over the throttle opening limit.

Timeout actuation: set the time in seconds the P2P will last.

Activation method: Select if the P2P will be activated by a White Input or by CAN (SwitchPanel or Input Expander)

Select if the ECU will start with this function enabled or not.

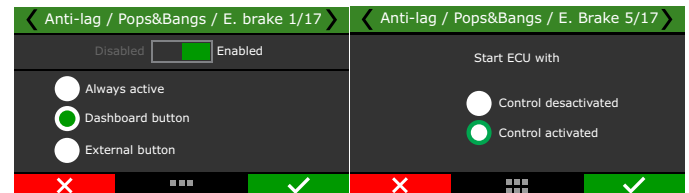

When an external button is defined, is necessary to configure if it's connected to an analog input or if it's over CAN bus using a Switch Panel.

There is an extra option to select whether it's a switch or a momentary button

19.30 Anti-lag / Pops & Bangs / Engine brake

These functions share the same basic settings, the definition of which one will be activated is based on the configurations and compensations.

Anti-lag: mostly applied for turbo engines to keep the boost up when throttle goes down, rally cars are the main application.

Pops & Bangs: commonly used in street cars to have flames and shots coming out from the exhaust.

Engine brake: used to keep the intake air valve or throttle blade with a different opening under engine deceleration, making it faster or slower.



NOTE

It's necessary TPS is correctly configured to the function to be activated.



Brake activation: Select if the brake pedal is going to be used to turn the feature on and off. To use this option Brake switch input is required.

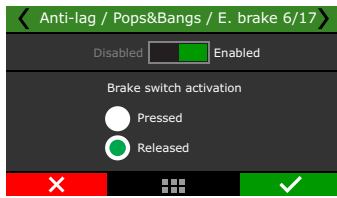

Clutch activation: Select if the clutch pedal is going to be used to turn this feature on and off. To use this option clutch switch input is required.

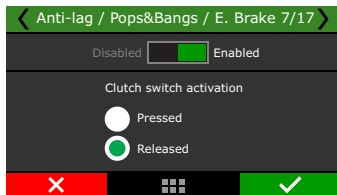

Ignition timing: define if the ignition timing will follow the main ignition table or if it is a fixed timing.

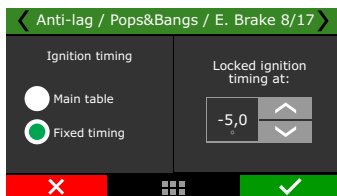

Adjust the activation delay, maximum duration time minimum RPM, maximum TPS and fuel enrichment to have the function working as expected.

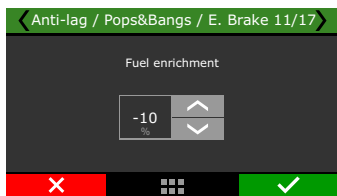
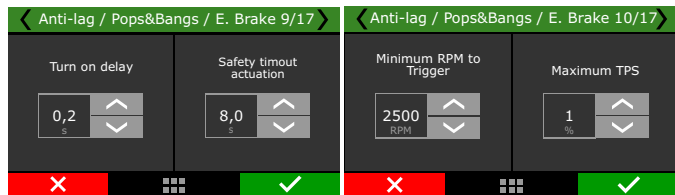

Ignition cut: adjust ignition cut % applied when the feature is active.

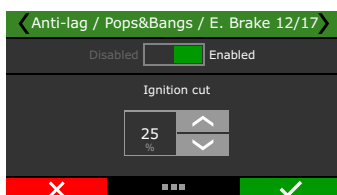

Idle actuator/electronic throttle position: it's possible to setup the amount of air going through the engine in this function. A fixed position can be used or a gear based table is presented.

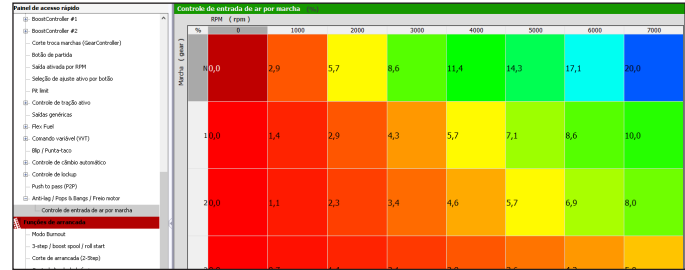
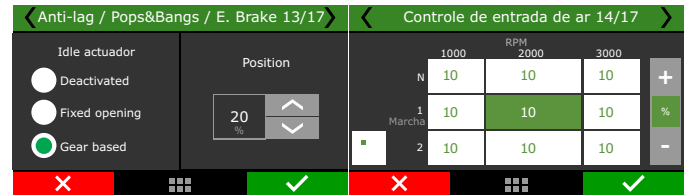

Activation ramp duration configuration time

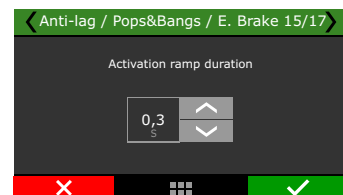

IMPORTANT
After the main configuration is done, auxiliary options are available under BoostController, Deceleration Cutoff and closed loop menus.

19.31 Compressed air control

This function controls the air compressor activation and regulates the pressure in the air reserve tank. Often used in automatic transmissions where the gear change is pneumatic.

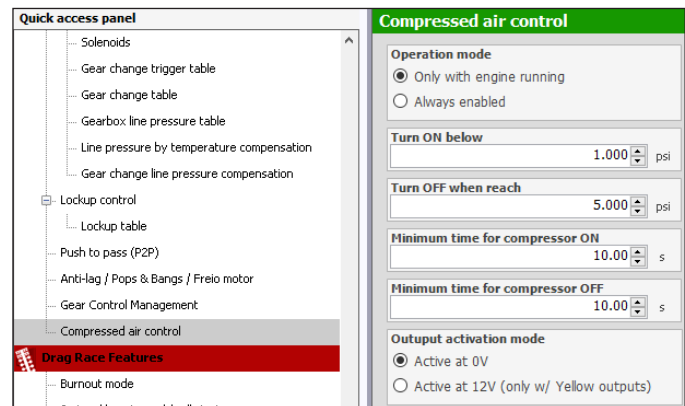

Operation mode: select if the compressor control will be enable only with running engine or always enable.

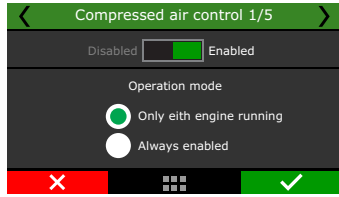

Select the reserve tank minimum and maximum pressure, the compressor will turn on and off by these limits. Select the max duration for the compressor to stay on.

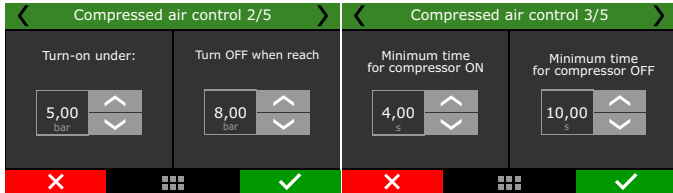

19.32 Advanced gear shift manager

This function is similar to the Power Shift (gear change ignition cut), yet with the possibility of gear change ignition cut and downshift enrichment.

This gear control is common in course race cars, when the gear change is made by steering wheel paddle shift, works combined with other functions for full control of an automatic transmission.

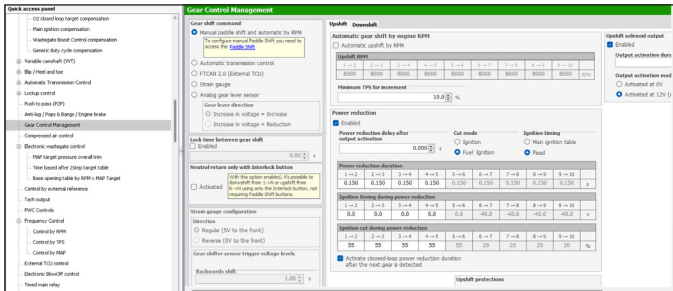

General configuration

There are 3 ways to control the gear change, through the automatic transmission control by paddle shift or by RPM, and also through an external TCU connected by CAN (FTCAN 2.0)

For Paddle shift / automatic transmission and external TCU, it is necessary to adjust the lock time for engaging the next gear (only for paddle shift), then select whether the gear will be placed in neutral when the Interlock button is activated and also the function will be activated when the blip/heel and toe function is active.

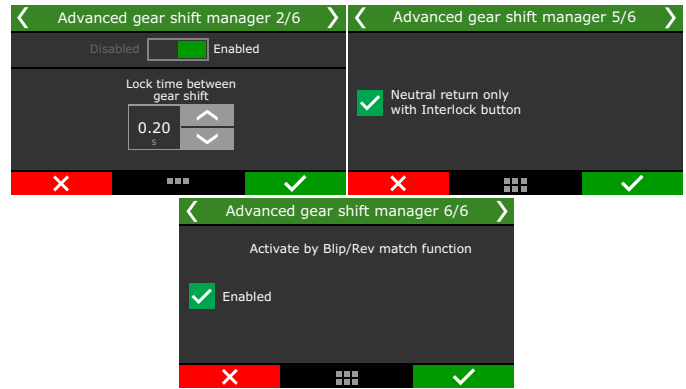
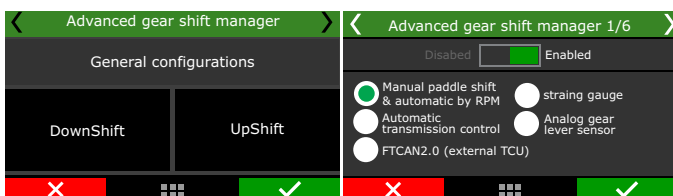

DownShift

When set for Paddle Shift or Automatic by RPM is necessary to adjust the RPM for each gear change.

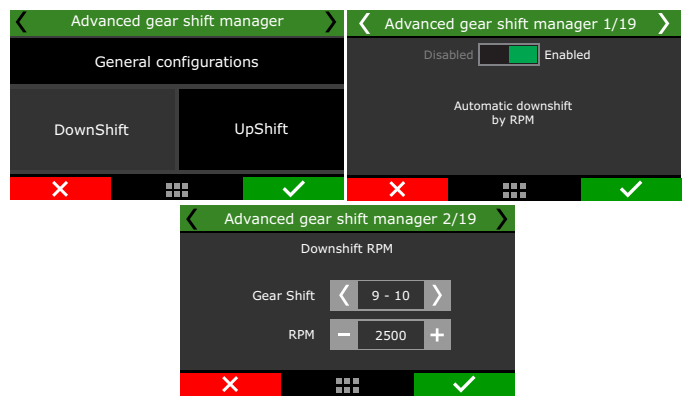

When set for External TCU or Automatic Transmission function, the downshift is configured at the third screenshot above.

Adjusting the delay for the power reduction to begin, this delay is the delay between the Paddle Shift pulling and the ECU to apply the downshift.

When "power reduction" box is selected, there will be more settings for downshift:

Cut mode: select if ignition cut or fuel and ignition cut.

Power reduction duration: adjust the power reduction duration for each gear change.

Ignition timing during power reduction: set the timing at each gear change.

Cut: adjust the cut percentage for each gear change.

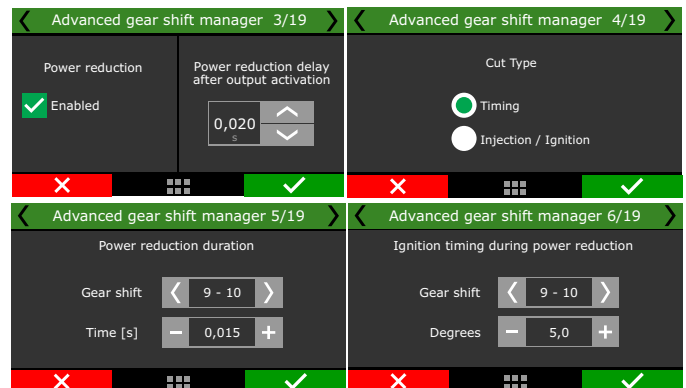

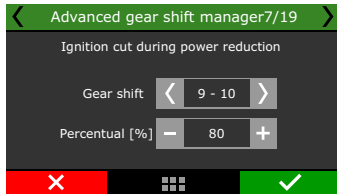

Closed loop control: When this option is selected the function will control the cut duration, if the gear engages before the power reduction time is over this function will anticipate the engine power return.

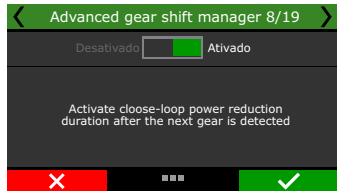

Adjust the additional throttle opening percentage for each gear change, also the duration time in milliseconds, similar to the "blip / heel and toe" function.

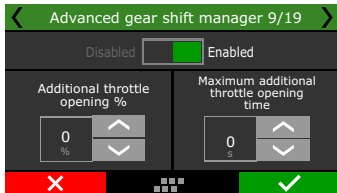

Downshift protections: Allows adjusting the maximum RPM for Downshifting, cancel the downshift if TPS is above specific percentage, and allows setting a TPS percentage which below it won't apply any power reduction.

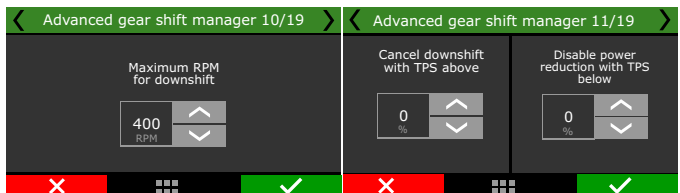

Additional power reduction after gearshift: Before the downshift the blip is activated, increasing engine RPM, this function can be used to avoid a "push" feeling during downshift.

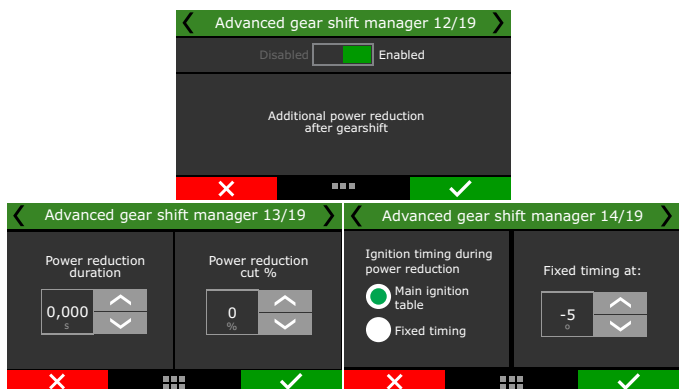

Stacked downshift: When activated this function will save the request for downshift if the request can't be applied at the time due to protections, up to the time limit applied and minimum TPS for the request stacking. Cancel the request when upshift is requested is also an option.

Example: The pilot pull downshift 3 times in a row, the ECU will schedule the request and apply when RPM is within the pre-set limits.

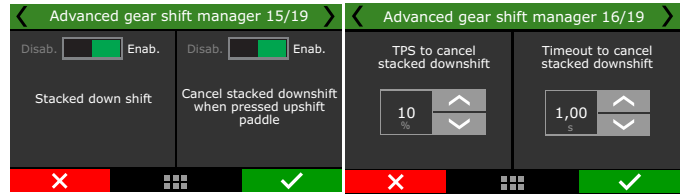

Downshift solenoid output: Set the output activation and duration.

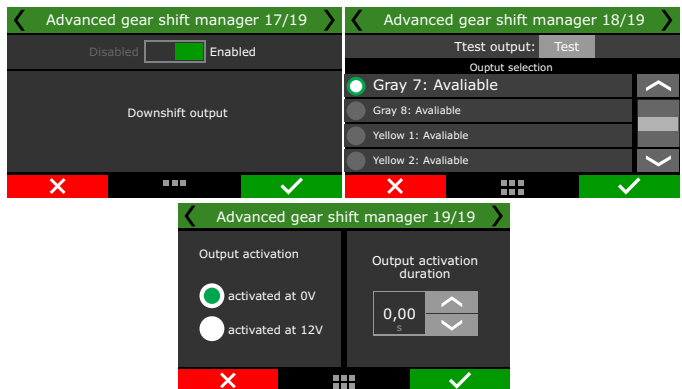

Upshift

Additional power reduction after gearshift: Before the downshift the blip is activated, increasing engine RPM, this function can be used to avoid a "push" feeling during downshift.

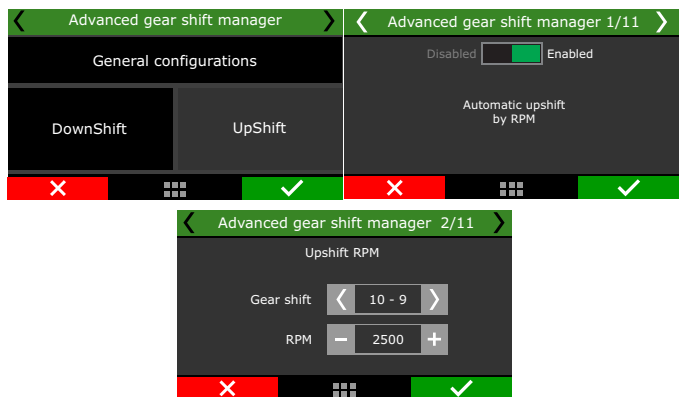

When set for External TCU or Automatic Transmission function, the downshift is configured at the third screenshot above.

Adjusting the delay for the power reduction to begin, this delay is the delay between the Paddle Shift pulling and the ECU to apply the downshift.

When "power reduction" box is selected, there will be more settings for downshift:

Cut mode: select if ignition cut or fuel and ignition cut.

Power reduction duration: adjust the power reduction duration for each gear change.

Ignition timing during power reduction: set the timing at each gear change.

Cut: adjust the cut percentage for each gear change.



Closed loop control: When this option is selected the function will control the cut duration, if the gear engages before the power reduction time is over this function will anticipate the engine power return.

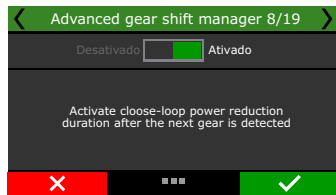

Upshift solenoid output: Set the output activation and duration.

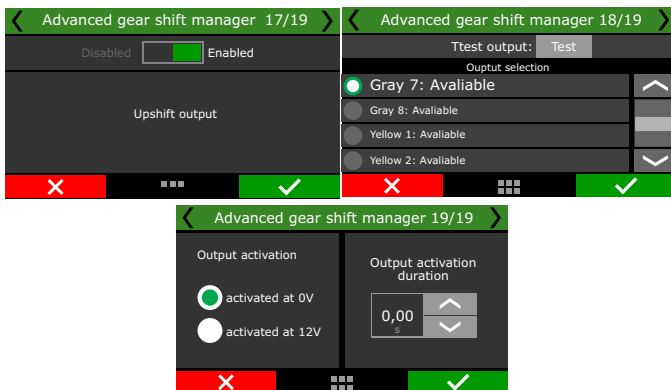

19.33 Electronic Wastegate Control

This function controls the electronic wastegate. When using this function, there's no need for BoostController function, and a lot of components can be removed if using a electronic wastegate, like hoses, O2 cylinder and pressure sensor.

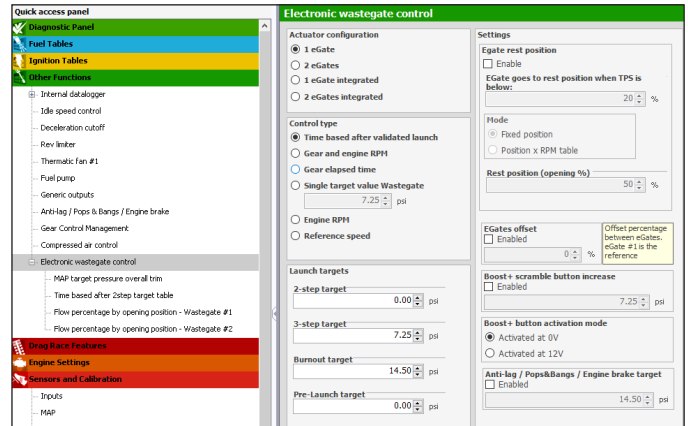

NOTE
This function is available to FT550 and FT600 only.

General configurations

Select the actuator configuration, if for 1 or 2 e-gates, if they are integrated.

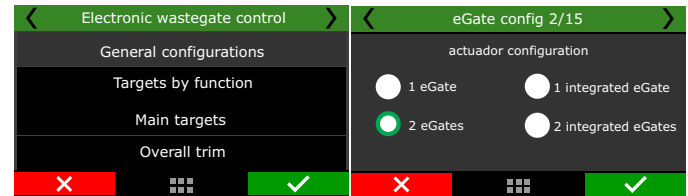

E-gate setup

eGate offset: this is for when using two e-gates, compensating any backpressure offset between the two engine sides.

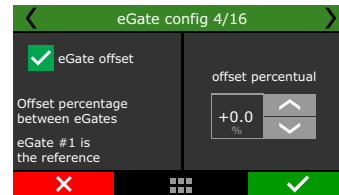

Rest position: set the minimum TPS for the eGate go to rest position. This percentage can be either fixed or by rpm.

Rest position opening: set a valve opening percentage for the rest position. This percentage can be either fixed or by rpm.

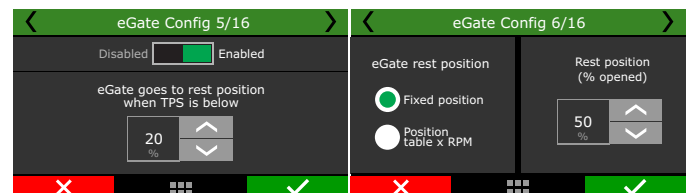

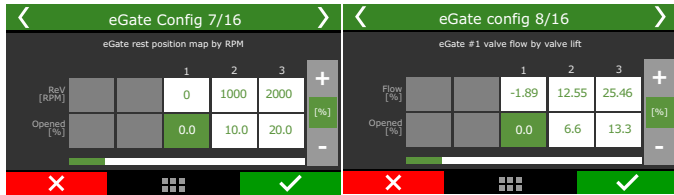

Boost+ button: Will increase or reduce the boost target when pressing the button.

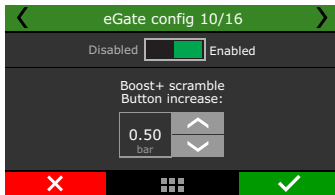

Set the e-gate outputs.

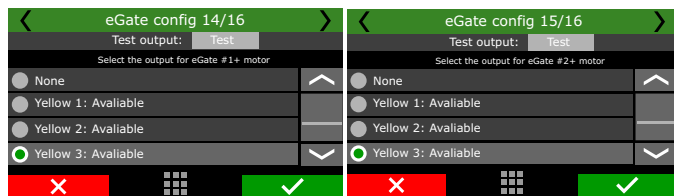

Targets by function

Set a individual boost target for each function: Boost target for 2-step, 3-step, burnout, pre-launch and one boost target for anti-lag/pops&Bangs/engine brake.

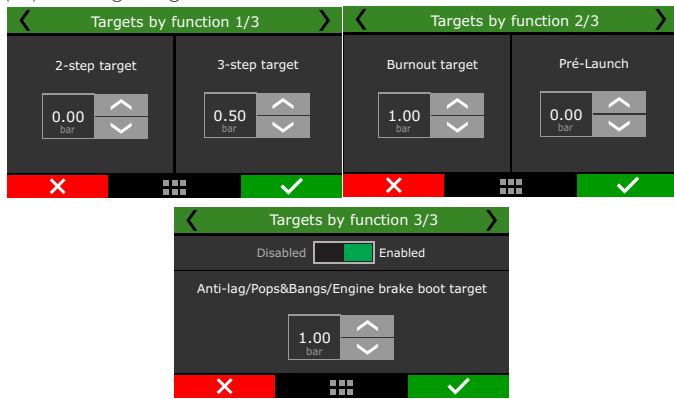

Main targets

The eGate control can operate with target by time after validated launch, gear and engine RPM, gear elapsed time, engine RPM, reference speed or just use a single target.

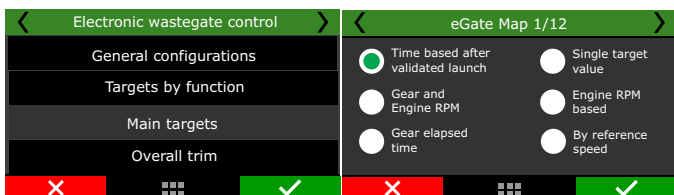

Overall trim

This adjustment is for quick decrease or increase the boost pressure. It changes according to the last screen.

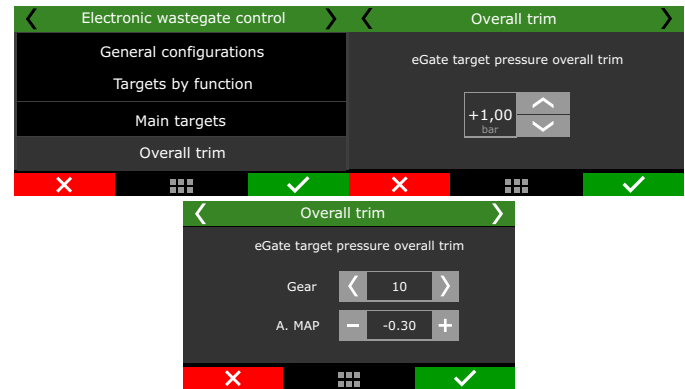

19.34 eGate Important Information

The eGate is the evolution of boost control, with the electronic wastegate your project is simplified.

FuelTech sells two models, 45 and 60mm valve. To control the eGate a FT Dual Power Driver (FTDPD) is needed.



eGate wiring

Wire	Goes to
Large gauge Red	Motor A tending towards 0% (goes to FT DPD blue wire)
Large Gauge Black	Motor B tending towards 100% (goes to FT DPD white wire)
Multi Core Wire	
Red	5V
Black	Ground for sensors (green/black)
White	Position Signal 0-5V (goes to a FT white input)
Orange or yellow	Temperature Signal 0-5V (goes to a FT white input)
Blue	Not used

19.35 eGate #1 and #2 position calibration

Once the inputs are selected, the calibration is needed, adjusting the valve opening and closing limits.

There are 2 ways to calibrate:

Manually: Same steps as for TPS calibration

Automatic: At FTManager go to "Sensors and Calibration/Inputs" and select the position Input for eGate #1 and #2 (if using two)

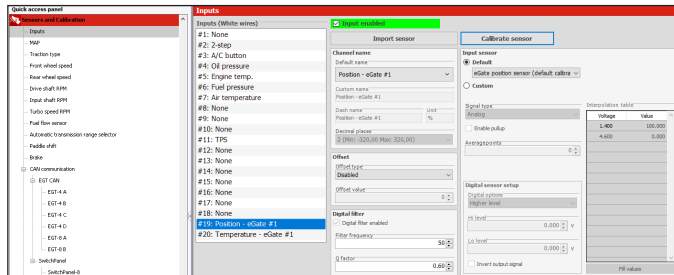

Once the input is selected click on "Calibrate sensor" for eGate position sensor calibration. A calibration screen will pop up, just click "Calibrate auto" for the automatic calibration process.

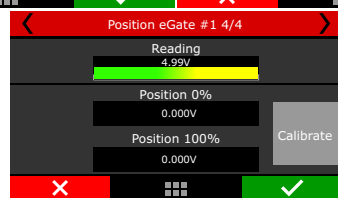
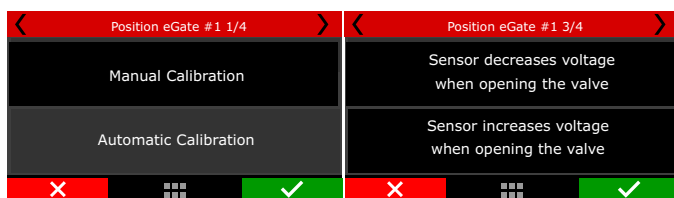
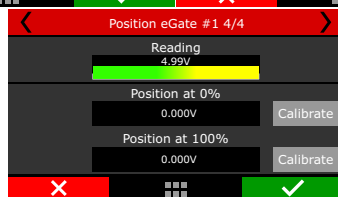
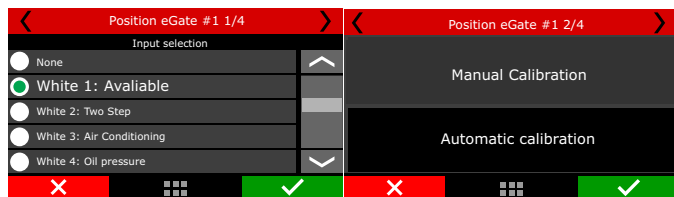
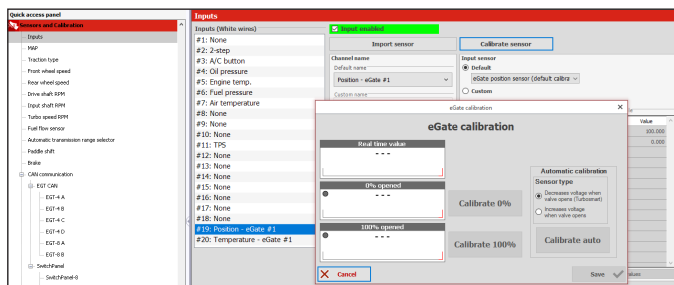

19.36 eGate #1 and #2 temperature

This sensor gives the eGate internal temperature, to utilize this sensor a white FT input should be connected to the yellow or orange eGate wire.

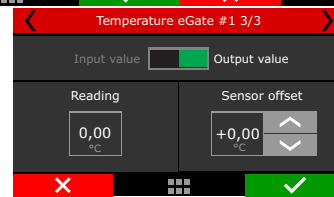
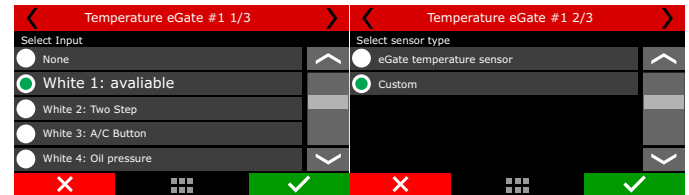
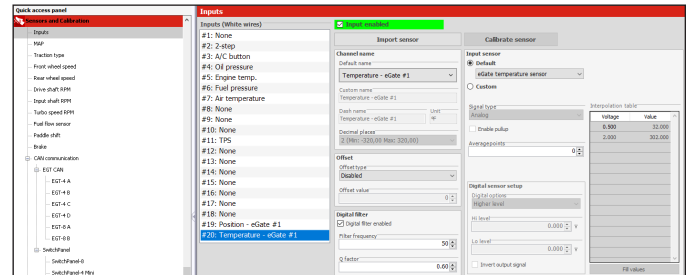

eGate installation diagram

- 1 - Input #1 - Red wire from FT DPD (connected to a ODD yellow output (#1-3-5-7) of the PowerFT ECU - **EGate Motor+**)
- 2 - Input #2 - White wire from FT DPD (connected to a EVEN yellow output (#2-4-6-8) of the PowerFT ECU - **EGate Motor-**)
- 3 - Blue output from FT DPD connected to the eGate red wire (Single core - **EGate Motor+**)
- 4 - White output from FT DPD connected to the eGate black wire (single core - **EGate Motor-**)
- 5 - Red from eGate multi core wire - connected to the 5V output (green/red wire) of PowerFT ECU
- 6 - Black from eGate multi core wire - connected to the Ground for sensor (green/black)
- 7 - **Position** White from eGate multi core wire - connected to the white input of PowerFT ECU (Position signal)
- 8 - **Temperature** Orange from eGate multi core wire - connected to the white input of PowerFT ECU (Temperature signal)
- 9 - Blue from eGate multi core wire - Not Used
- 10 - Connection for **gray outputs** it is necessary to use a 10K 1/4W resistor in each output
- 11 - 10K 1/4W resistor



NOTE
If yellow outputs #1 or #2 are used it is necessary to use another pair of outputs.



IMPORTANT
To use a gray output to drive the FT DPD, it is necessary to install a 10K 1/4W resistor in this output.

Diagram yellow outputs

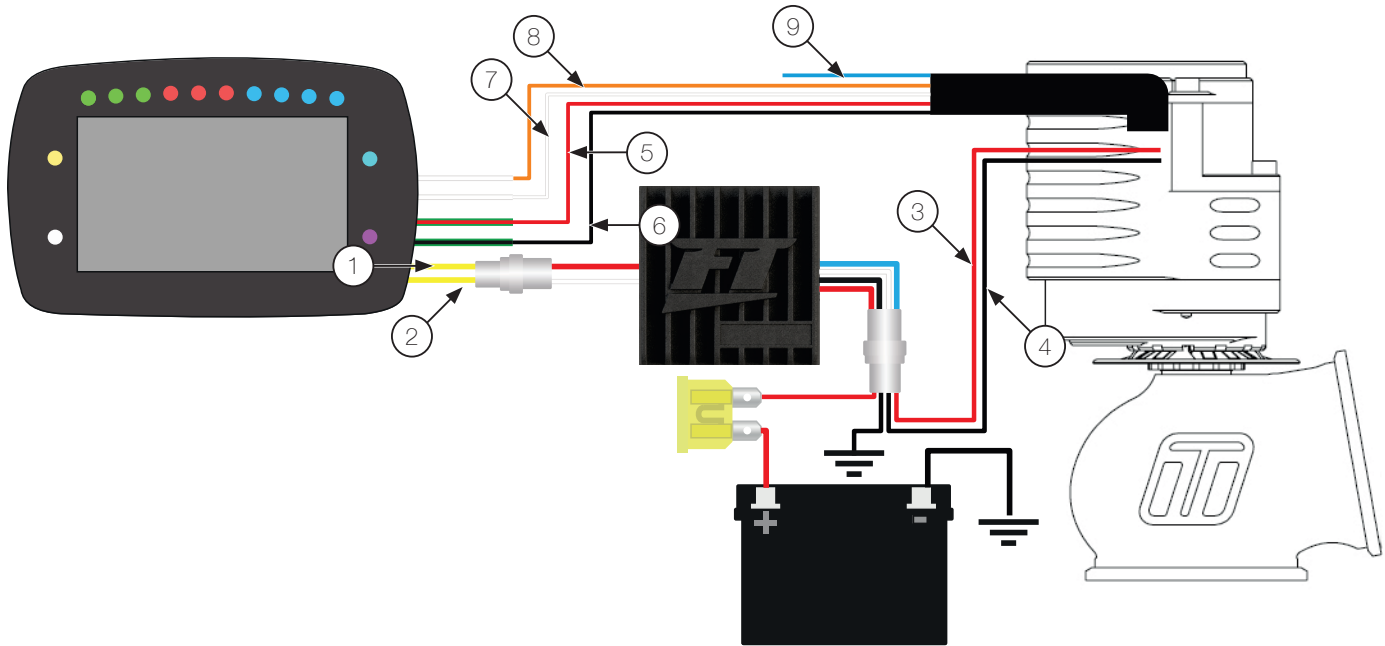
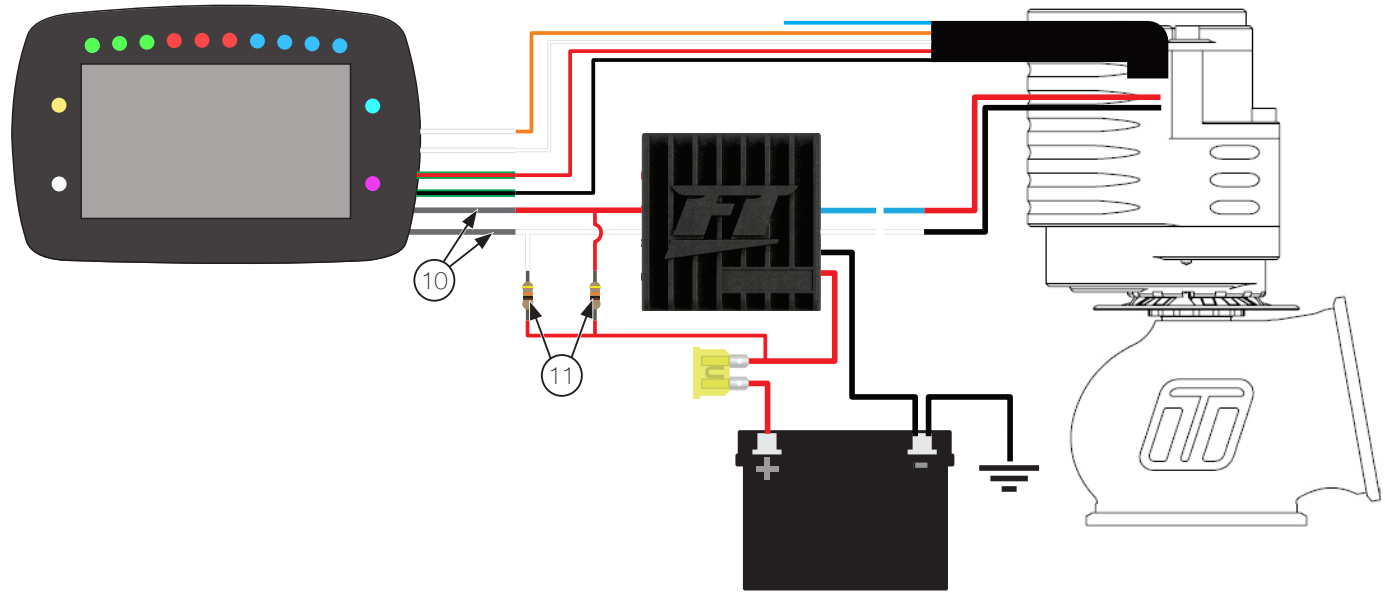

Diagram gray outputs



19.37 Control by external reference

This function allows ignition and ETC bypass, through reading from the stock ECU when it is working in parallel with FT ECU.

The FT white inputs will get the data from the stock ECU (ECM) and either replicate at the engine the same data it is reading, or apply the tune configured at FT ECU, by user's choice.

This function is usually configured to mirror the data from the stock ECU when idling and low load, so the stock ECU won't detect any anomalies.

ETC bypass requires:

- An electronic throttle body plugged to the stock harness, controlled by the stock ECM but not installed at the intake manifold (external throttle). This is only for FuelTech reading.
- Have a second Throttle body installed at the intake manifold and connected to the FuelTech ECU
- Set up the Throttle body controlled by the stock ECU as "External Throttle"

For ignition bypass just set up the white inputs as "Ext. Ignition Timing X". This wire must be connected to the ignition signal wire at the cylinder in the firing order. The stock ECU signal (not controlling the ignition timing at the engine anymore) is read by the FT ECU.

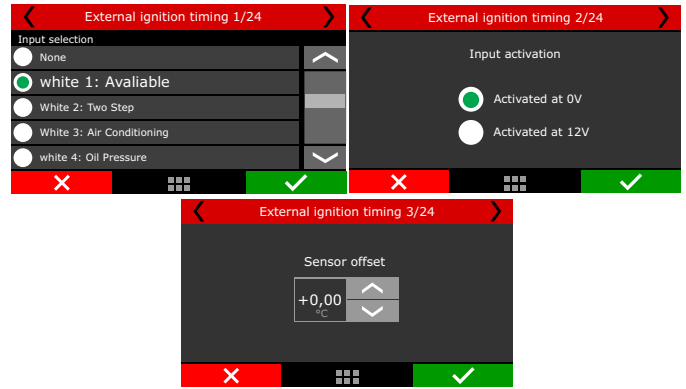
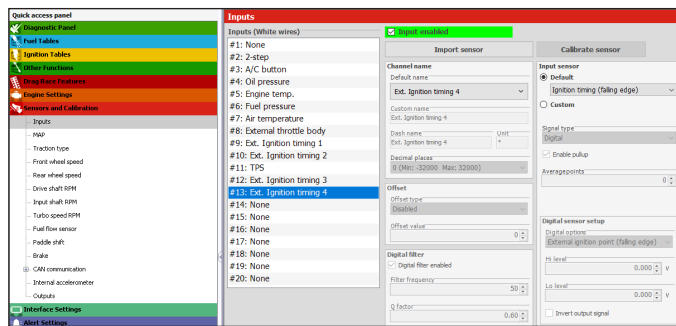
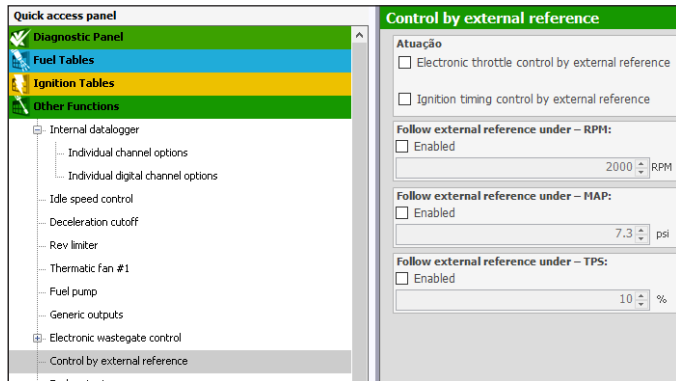

Operation

Select the operation method from the options below, defining when to replicate the stock Throttle position and ignition timing received from the stock ECU and when to switch to the FT control.

Settings:

Follow external reference under RPM: select the RPM with FuelTech ECU will kick in, below this RPM FuelTech will replicate stock ECU behavior.

Follow external reference under MAP: select the MAP with FuelTech ECU will kick in, below this MAP FuelTech will replicate stock ECU behavior.

Follow external reference under TPS: select the TPS with FuelTech ECU will kick in, below this TPS FuelTech will replicate stock ECU behavior.

The timing and throttle control will only be made by FT ECU if **all parameters are validated**, otherwise the control will be made by the stock ECU (FT ECU mirroring)

Example: If RPM and MAP are above the determined value, just TPS is still below the determined value, the control will be made by the stock ECU.

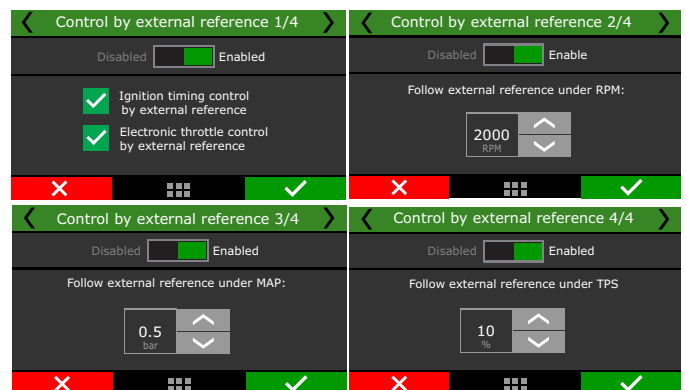

19.38 PWC Controls

These features help with the handling of Yamaha and Seadoo watercraft. It is necessary to have the CAN network correctly configured according to the brand and model for these configurations to work.

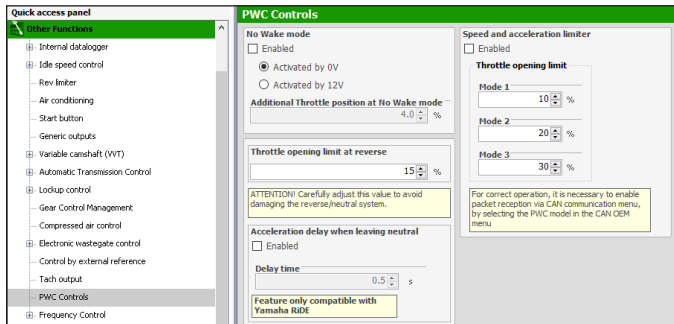

No Wake mode: The function is activated by the input of the No Wake button that can be activated by 0V or 12V, when the input is activated the electronic throttle will open as set.

Maximum throttle opening in Reverse: This percentage will limit the throttle when in reverse gear. Gear detection must be selected by the PWC steering control. Be careful not to use too high values, as it can damage the reverse system.



19.39 Frequency control

This feature reads frequency through a white input and repeats its signal at an output. Using its tables, the output frequency can be modified as needed.

Using the auxiliary tables, it is even possible to limit the output frequency by RPM, MAP or TPS, which makes it act similarly to a clamper.

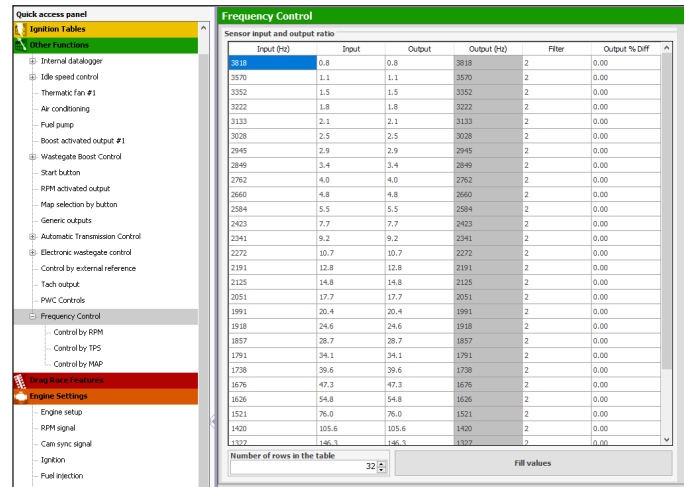

Input (Hz): enter the values that will be read by the white input
Input: enter the value corresponding to the reading you want (example MAF reading in g/s)

Output: fill in the values that you want to be sent in the output of the function. If you want to change the value, just fill in the desired value or fill in the same input value to just repeat what the function read from the sensor.

Output (Hz): is the frequency value, calculated by the software, which will be sent at the output of the function.

Filter: digital filter to improve the output signal and eliminate unwanted variations (Example of a MAF sensor that can have its signal affected and vary at idle and low load situations due to the addition of a turbocharger).

Difference % output: calculation made by the software to simplify the view of what has changed between input value vs output value.

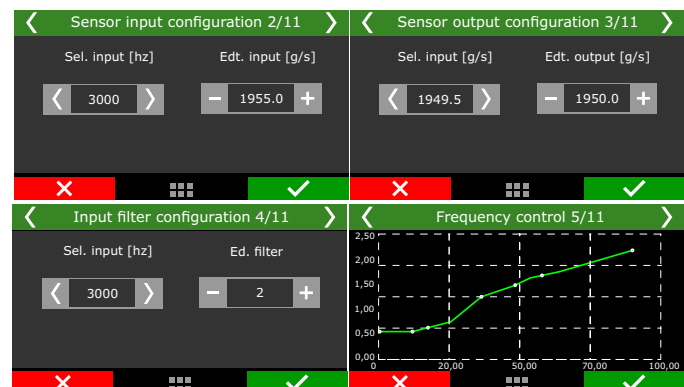



19.40 Water pump

This function was developed to control an external water pump, necessary for electrified cars where there is no provision for a belt driven water pump

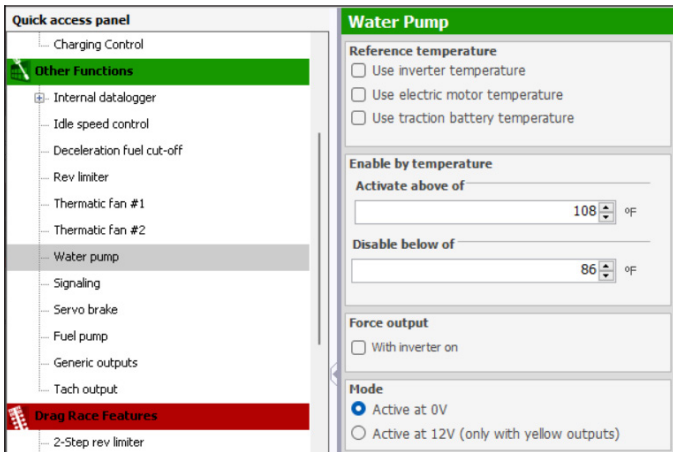

Reference temperature: Specifies the required temperature source to turn on the water pump; inverter temperature, electric motor temperature or traction battery temperature

Enable by temperature: Adjust the minimum and maximum range of temperature to turn on the water pump output.

Mode: Set the output trigger that will activate the control.

Force output: This option force activates the water pump as soon as the inverter is activated, regardless of the configured temperature.

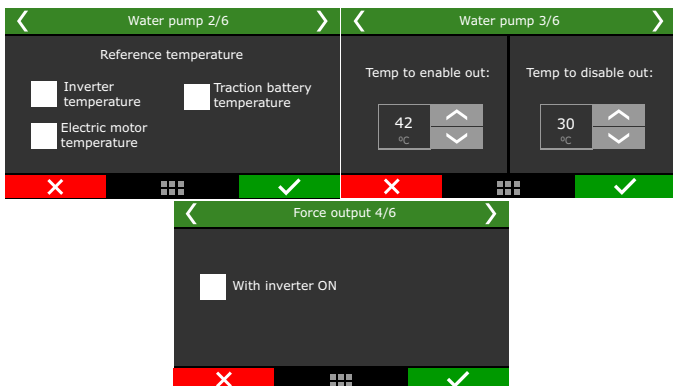

19.41 Vehicle lights control

This function was developed for electric vehicles to activate the brake and reverse lights.

Brake light by pedal: when pressing the brake pedal on electrified vehicles, the battery pack regeneration system will enable.

Adjust the percentage values for the start and end of the battery pack regeneration system. Requires either a brake activation switch or a brake pressure sensor to enable the function.

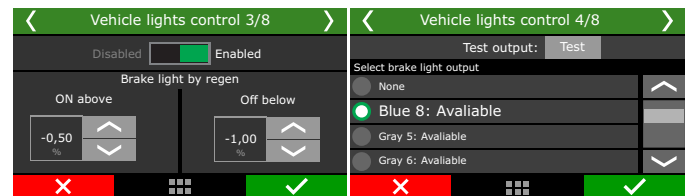
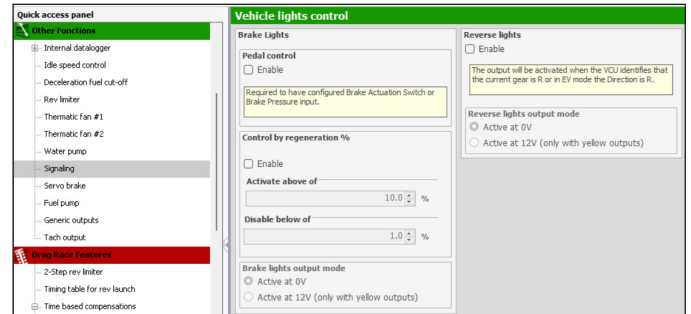

Reverse light: Set the output that will activate the reverse light when enabling Reverse in the VCU.

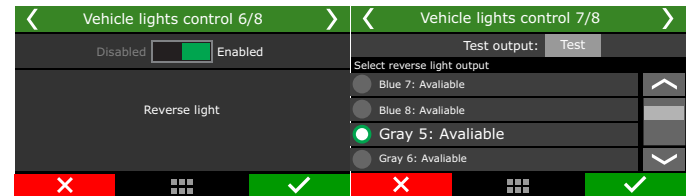

19.42 Power brakes control

This function was also developed for electrified vehicles, it is required to create a vacuum for the brake pedal as there is no mechanical production of vacuum. After the function is activated, it is necessary to configure the brake vacuum input, define the sensor type, adjust the sensor offset if necessary and configure when the brake vacuum booster will activate and deactivate.

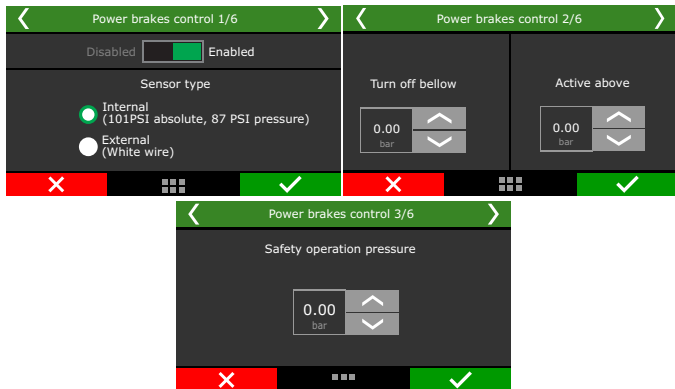
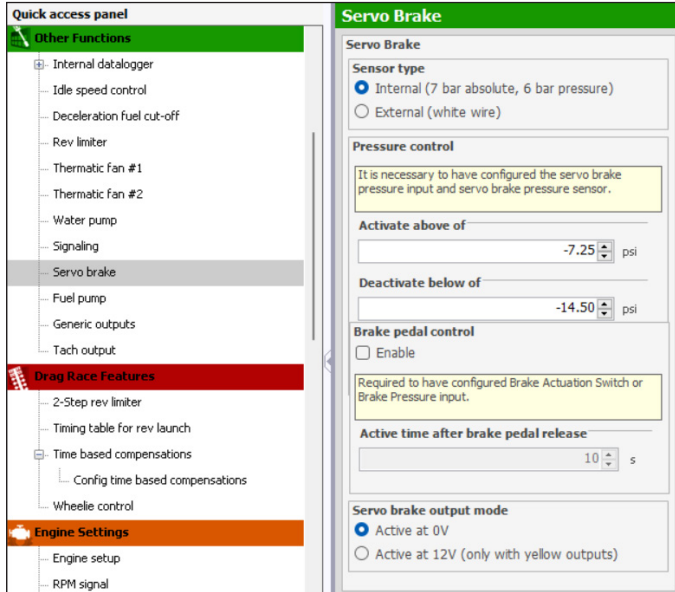

Configure, if necessary, a time in which the brake servo will be active after the brake pedal is released.

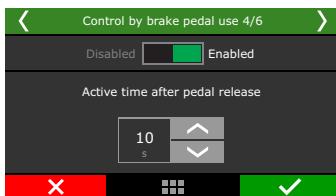

19.43 Timed main relay

This function activates a timed output when turning on the ECU to activate a main relay, normally controlled by the original ECU.

The function working: it is activated in parallel after as the ECU receives 12V power, in this case it is necessary to use a diode (1N4007) between the positive of the start button and the 12V of the ECU. (See diagram below).

Always enabled: the relay is activated after turning on the ignition key. In this case, it is MANDATORY that the option "Disable output when pressed - Start button - Shutdown" is checked. Otherwise the ECU will not turn off.

Timed: When turning on the module, the relay is activated for a defined activation time, after which the relay is deactivated and the ECU is turned off, returning to activation when it detects an RPM signal.

During starting: the relay remains activated while in cranking and the desired time after the engine is running.

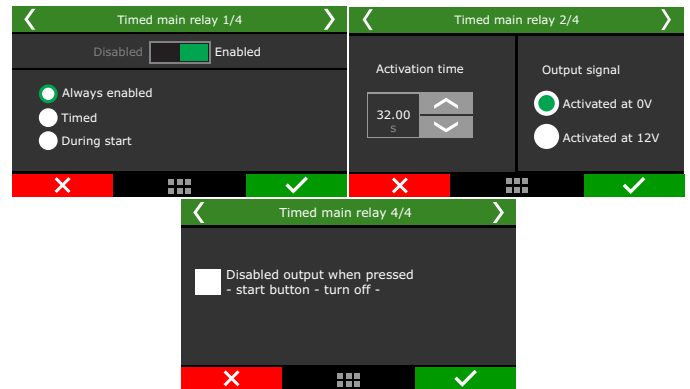
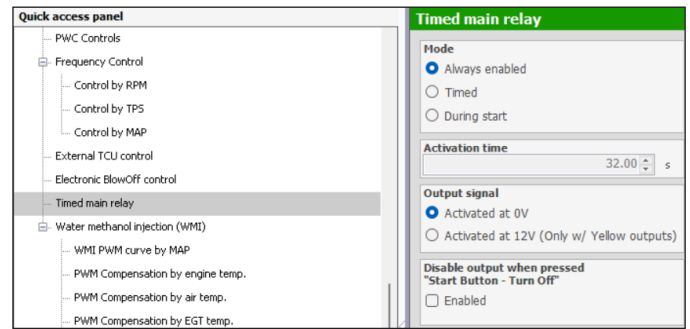
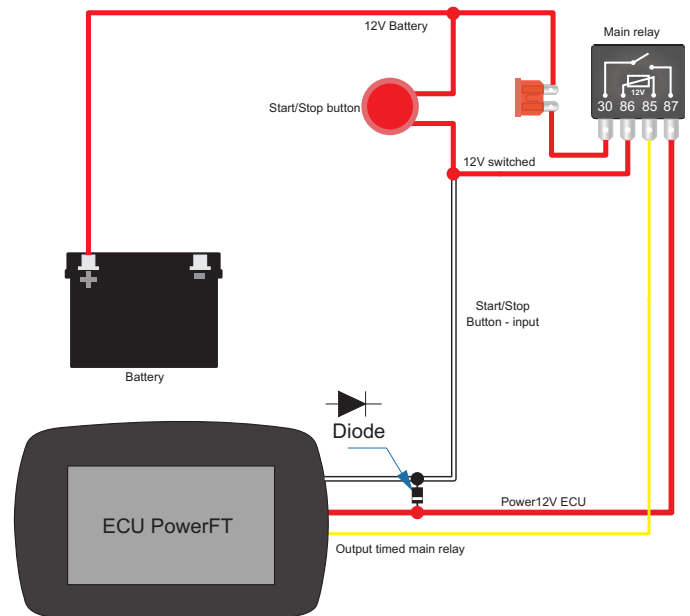

Diagram for connecting a Jet Ski with 1 Start/Stop button



19.44 Electronic Blow Off control

This function is dedicated for controlling 2-wire electronic blow-off valves. It is based on the TPS variation to be activated.

Activate with Delta TPS variation: Minimum TPS variation rate to activate the valve opening. This variation is negative because it is the closing of the throttle that activates the opening of the valve.

Deactivate with TPS variation: Minimum positive variation rate to close the valve again. This variation is positive because it happens with the opening of the throttle.

Minimum MAP: Minimum turbo pressure above which valve opening will occur.

Maximum activation time: Maximum time that the valve remains open. The valve closes instantly if the TPS reaches the deactivation range, regardless of time.

Always activate: This function keeps the valve open in the following conditions: Idle, 2-step and 3-step.

Output activation mode: By 0V or 12V (yellow outputs)

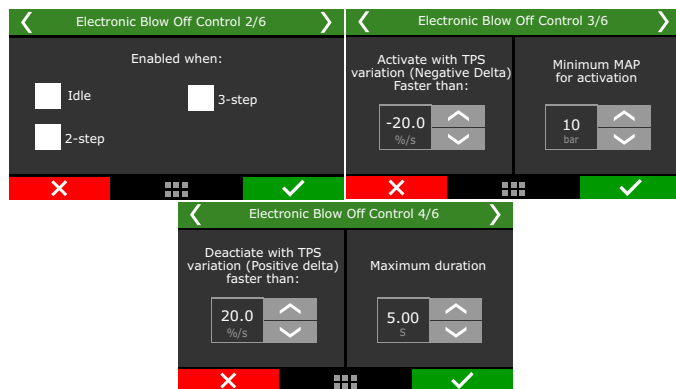
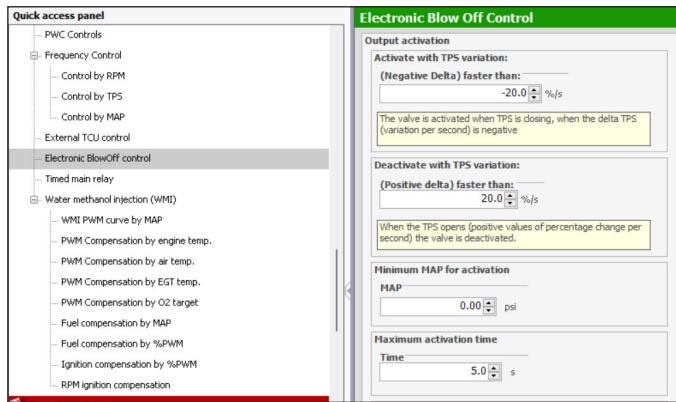

19.45 External TCU control

This function was developed to suit DSG gearboxes (DQ500 and DQ250).



IMPORTANT

- To use this function it is necessary to perform an gearbox remap!!!
- The function does not work with gearboxes that have an electronic park brake.

Pinout DQ250

- 1 - K-LINE: diagnostic pin, pin available only on gearboxes with older mechatronics.
- 10 - CAN HIGH
- 11 - 12V Battery (30A)
- 13 - 12V switched (15A)
- 15 - CAN LOW
- 16 - Ground
- 18 - 12V Battery (30A)
- 19 - Ground

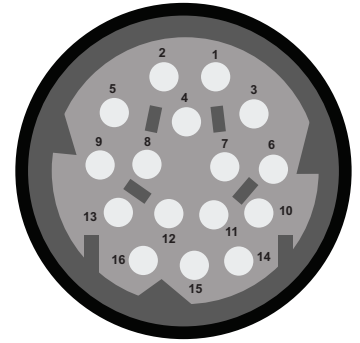

Pinout DQ500

- 2 - 12V Switched (15A)
- 6 - CAN HIGH
- 7 - CAN LOW
- 9 - 12V Battery (30A)
- 16 - Ground

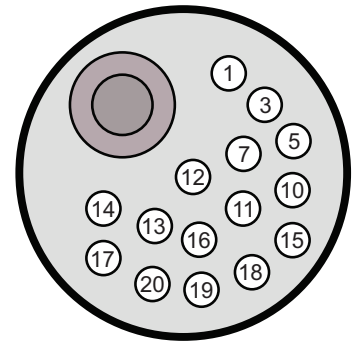

Functions necessary for the correct functioning of the DSG gearbox

It is necessary to activate several functions for the DSG to working correctly. Below is the list.

- External TCU control
- Advanced gear shift management
- Gait detection
- Fuel consumption control

Remap

To function works correctly, it is recommended to remap the gearbox, disabling any errors that occur.

The RPM, gear shifting speed, gear pressure and kickdown can only be changed directly in the gearbox TCU via Remap.

To carry out Remap, we recommend looking for specialized workshops.

Mandatory sensors

For the DSG to works correctly it is necessary to have some sensors connected to the FuelTech.

- Rotation
- Engine temperature
- TPS
- Brake Pedal
- Wheel speed

Optional:

- Paddle Shift (connected directly to the FT ECU)

Configuration in FTManager for FuelTech ECU

- Enable the necessary functions in FTManager.
 - External TCU Control
 - Blip/Heel and toe
 - Gear control Management
 - Gear detection
 - Fuel consumption control

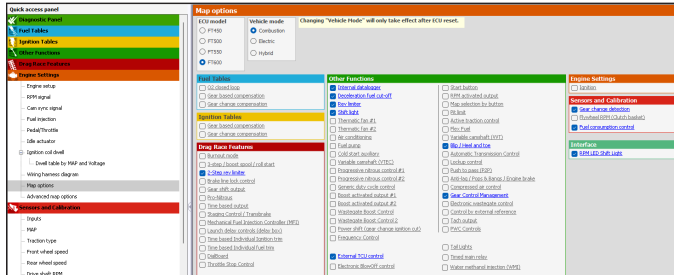

- Access the "CAN Communication" function, select the CAN B port and set it to "OEM CAN".

Click on the menu in the sidebar "OEM CAN" and select the External TCU - DSG option from the list

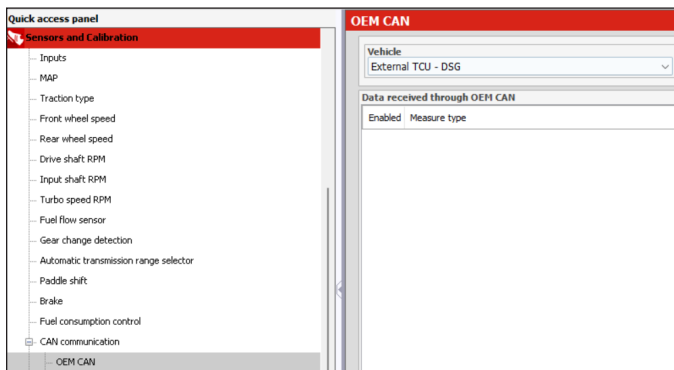
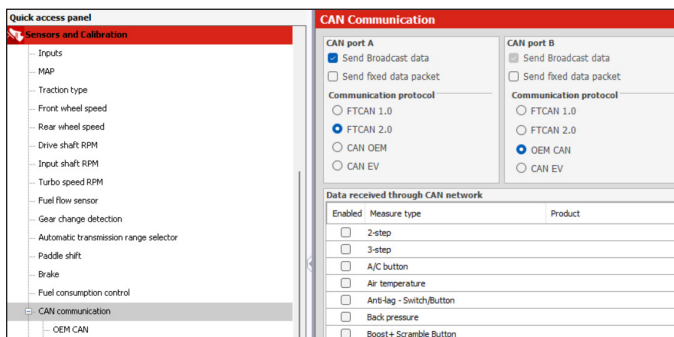

- Access the menu "Other functions / External TCU Control" and configure the function.

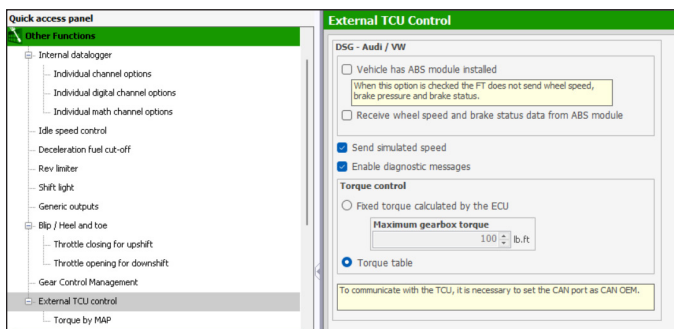

Vehicle has ABS module installed: this option allows you to obtain the speed through the ABS sensor (only for Audi 8L/8P, Golf Gti Mk4/4.5).

Send simulated speed: This option must be selected when the vehicle does not have a wheel speed sensor installed in the gearbox. This option is recommended for drag cars with DSG.

Enable diagnostic messages: allows you to record DSG log channels such as: clutch pressure, oil temperature, among others.

Torque control

Fixed torque calculated by ECU: This option allows the FT to calculate torque. For this calculation to be correct it is necessary to have the following parameters configured correctly.

Injector flow in the "Engine Settings / Fuel injection" menu. Fuel flow in the "sensors and calibration/fuel consumption" menu BSFC in the "engine settings/engine setup" menu.

With these parameters correctly configured, the ECU will estimate the torque and send it to the DSG to control clutch pressure and gear change.

Maximum gearbox torque: it is a torque limiter for the DSG, the value placed in this field will be the gearbox operating limit.

Torque table: This option uses a table that must be configured in percentage of torque, where 0% will be ONm and 100% will be the gearbox torque limit.

Gerar Model	Torque Limit
DQ250	630Nm
DQ500	800Nm

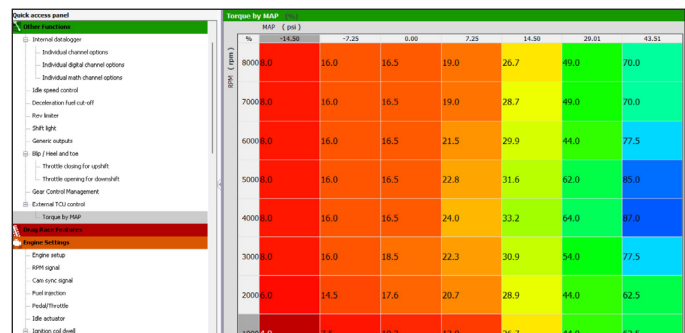

- Access the "Sensors and Calibration/Gear change Detection" function and select the "External TCU" option

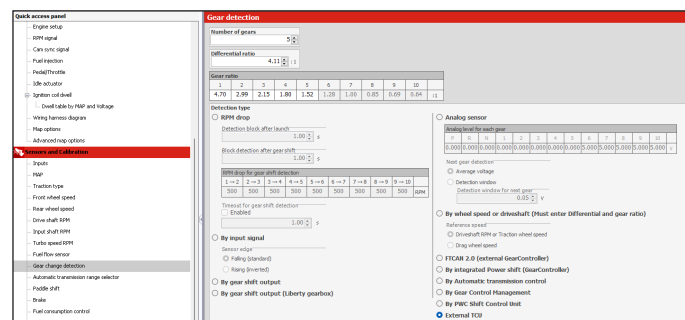

- In the "Automatic transmission range selector" function, select the "External TCU (OEM CAN)" option

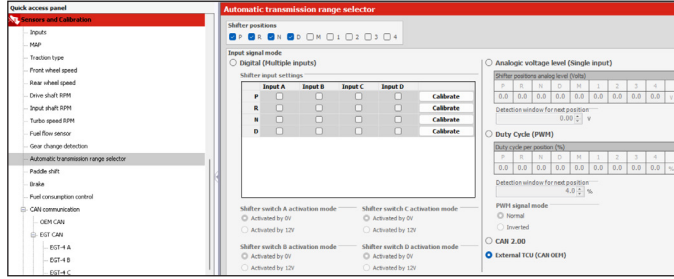

- Access the "Other functions / Blip/Heel and toe" function and configure the control to use Gear control Management (GCM).

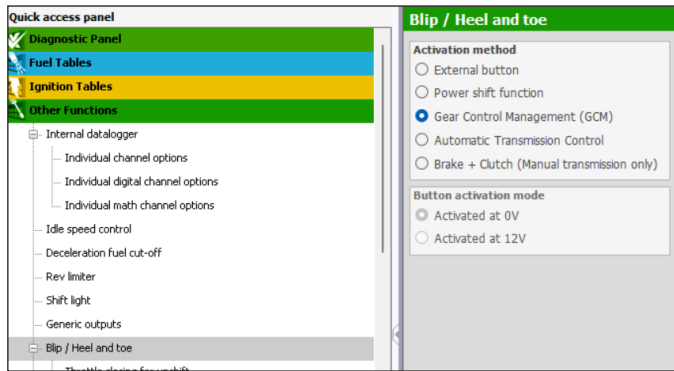

- The last step is to access the "Gear Control management" function and select the "FTCAN 2.0 (External TCU) option and check the check box "Activate Blip/Rev match function"

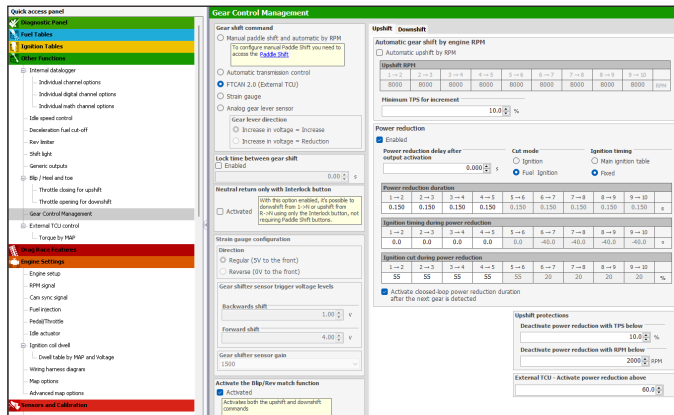

After following out these steps, the DSG control will be working. If you have any questions, please contact our technical support.

19.46 Water methanol injection (WMI)

The function controls a mechanical injection system of a mixture of water and methanol into the intake manifold.

The control works through a pump and solenoid, based on PWM curves and temperature conditions, and applies ignition and fuel corrections.

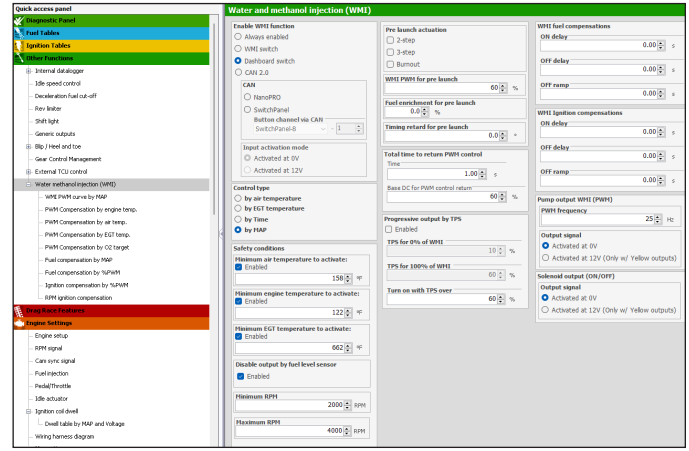

Enable WMI function: there are four options for activating the function, always enabled, WMI switch, Dashboard switch or CAN 2.0.

Control type: Select the type of WMI drive control, there are four options by air temperature, by EGT, by time or by MAP.

Safety conditions: Enable which conditions will be used for control, adjust the minimum and maximum RPM for the function to be activated.

When selecting the option "Disable output by fuel level sensor" it is necessary to configure an input as "WMI - Tank level".

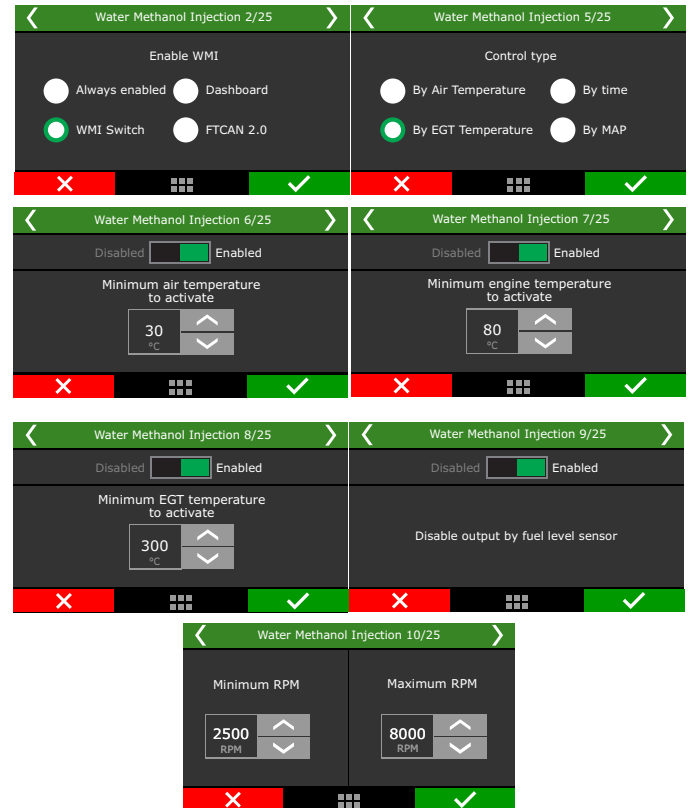

Pre launch actuation: Determines whether the function will be activated in pre launch conditions, the enrichment in % of injection and the timing delay.

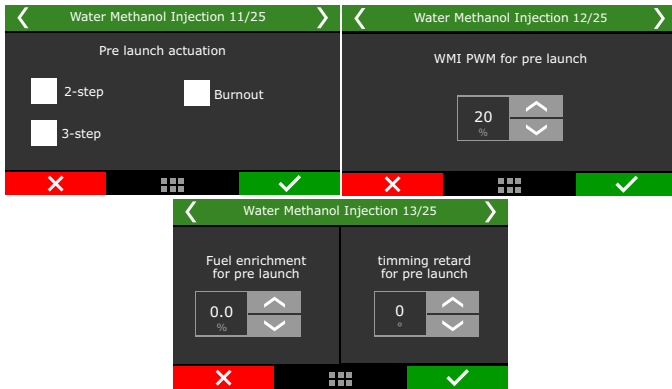

Pump output WMI (PWM): Adjusts the PWM drive frequency for the WMI pump and the output voltage.

Solenoid Output: Determines the output voltage to the solenoid.

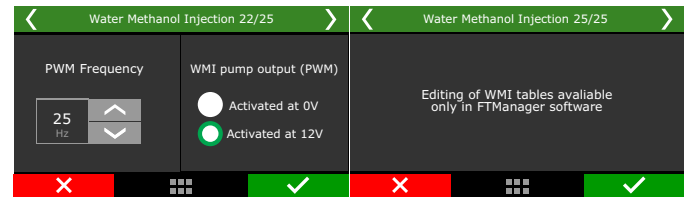

Total time to return PWM control: Adjusts the PWM activation ramp, through the ramp time and the PWM at which the ramp will start.

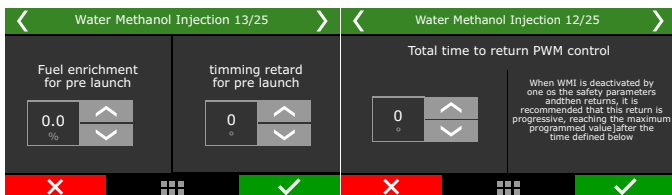

Progressive output by TPS: If enabled, determines a minimum and maximum TPS value for gradual TPS activation. If disabled, it follows a minimum TPS value for full activation of the function (On-Off).

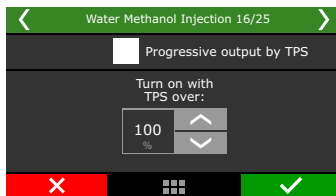

Fuel compensations: adjusts the delays for starting and stopping the compensation, as well as the ramp time to reset the compensation.



Ignition compensations: Adjusts the delays for starting and stopping the compensation, and also the ramp time to reset the compensation.

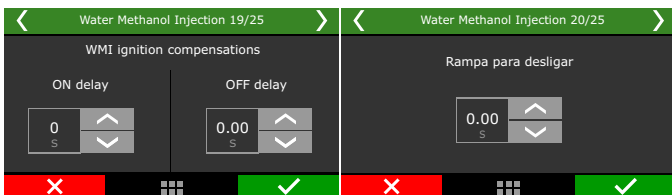

20. Drag race features

This menu gathers all options normally used in drag race applications. All the time based features start after releasing the 2-step button which indicates the moment when the vehicle launched.

20.1 Burnout mode

The Burnout Mode is a function used to facilitate the processes of warming up the tires and using the two-step.

When pressing the two-step button, the two-step function is activated.

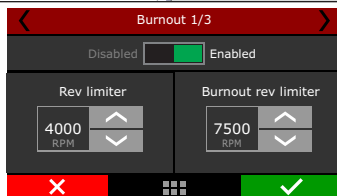
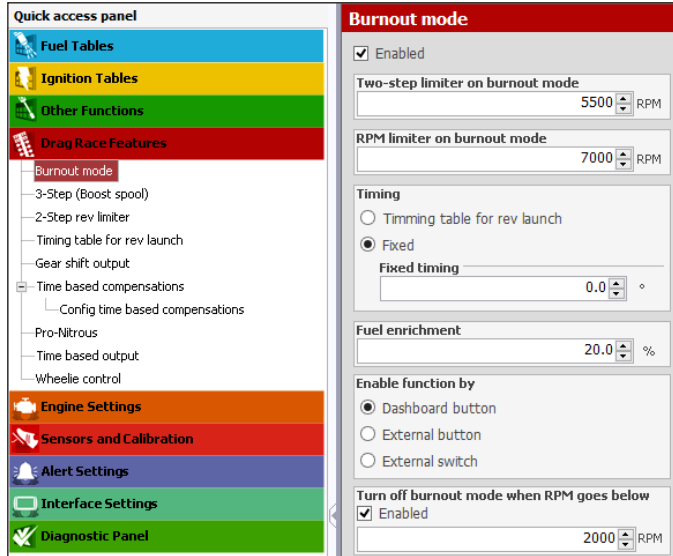

When Burnout mode is activated, it disables the standard RPM Limiter, instead the ECU uses this RPM limiter as the engine's RPM limit.

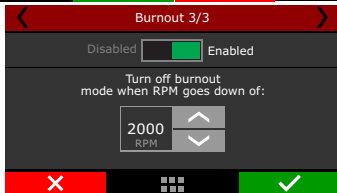
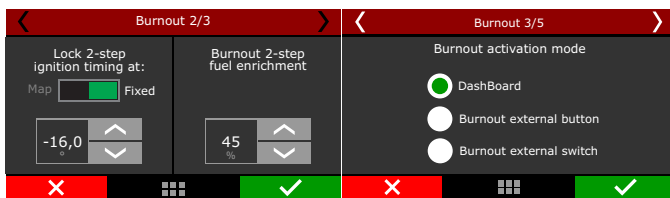

But when the two-step button is being pressed, the value considered is the one set for the two-step parameter. The values adopted for ignition timing retard and enrichment are the ones configured on the two-step function.

There are 3 different ways to enable the burnout mode:

- By dashboard button: a touchscreen button in the FT dashboard enables the function.

- By an external button* - a white input is required. One click to enable and another to disable the burnout mode.
- By an external switch* - similar to the button, but in this case the function is enabled while the input is grounded.

* In the FTManager, this setup is at "Sensors and calibration" - "Inputs" The burnout mode can be automatically disabled by RPM. When the engine RPM is below an editable value. This option is not available for "external switch" option.

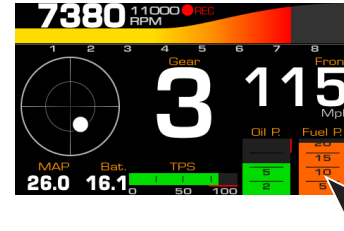

20.2 3-step (boost spool)

The 3-step is quite similar to the 2-step function, however, with more aggressive strategies to assist in the boost spool.

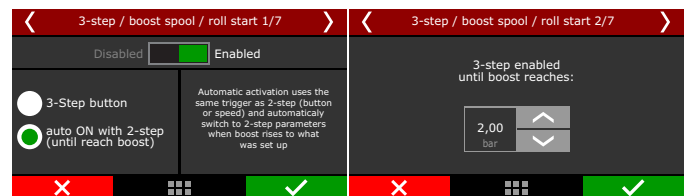
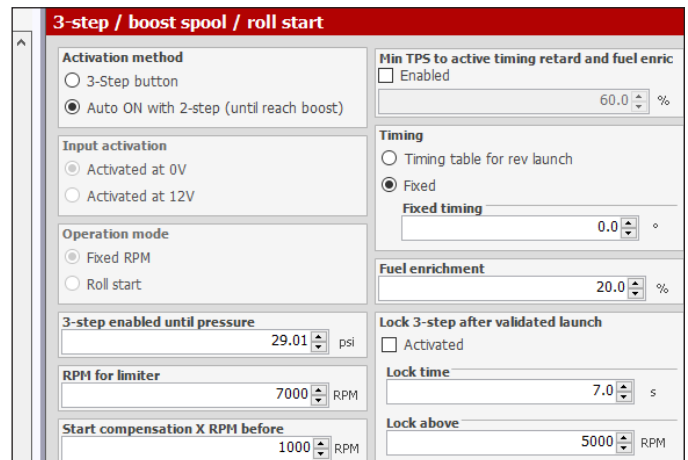

There are two ways to activate this function, one uses an external button (must use a white wire attached to a button, usually on the foot brake) and the other is through 2-step button.

In this case, you must press the 2-step button and the 3-step will be activated until the engine reaches a predefined boost pressure, at this point the 3-step will be deactivated and the 2-step will be activated. If using an external button to trigger the 3-step, when it is triggered simultaneously with 2-step button, the 2-step will prevail.

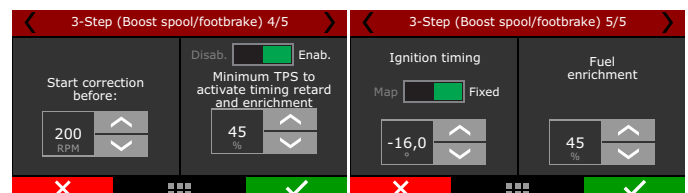

It is possible to start the 3-step mode before the RPM rev limiter and to set a minimum TPS value to activate it.

20.3 2-step rev limiter

The two-step active with a retarded ignition timing, and a mixture enrichment given in percentage (also programmable).

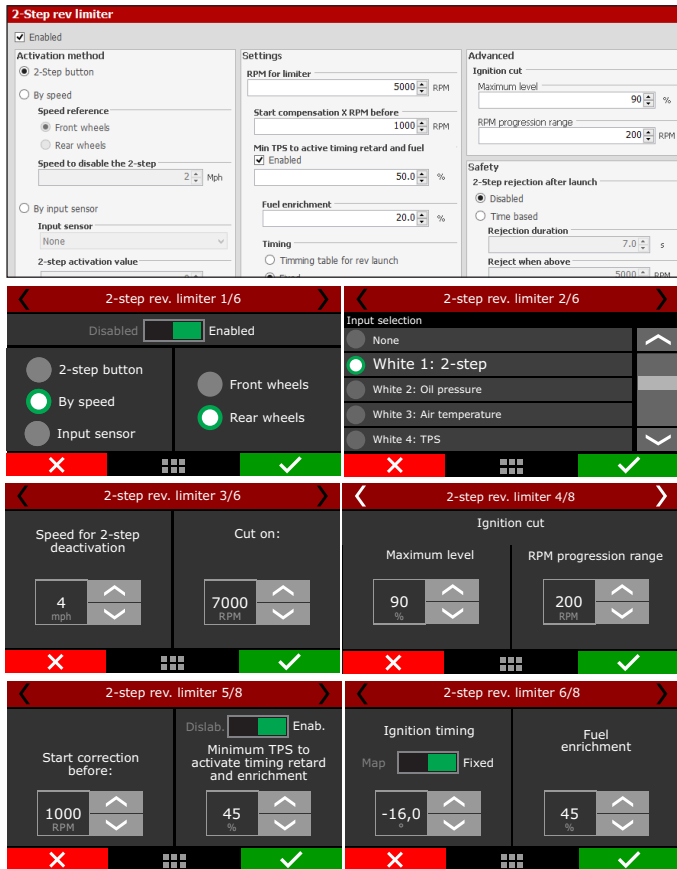

A maximum electronic throttle opening can be set, allowing the driver to launch with the pedal to the floor while the ECU controls the maximum position of the throttle to aid in getting standardized launches. Another option for the 2-step activation is to use a signal directly from a sensor. In the case of an air temperature sensor (which we recommend), a button is wired in parallel to the sensor wire, and when the button is pushed the signal is grounded. Once the signal is grounded, the ECU will read the maximum sensor temperature, which can be configured as the value for activation of 2-step.



WARNING
 When the 2-step is by wheel speed, its working can be checked through the first page of Diagnostic Panel, since it is not being used any 2-step button input.



To prevent the driver to activate the 2-step on a run, there are 2 safety parameters. Block 2-step by time or by RPM. This way, even if the driver presses the 2-step button, it will not activate before the time slip or above the RPM.

When using the 2-step by an input sensor, you must indicate an above or below value which the 2-step must be considered active.

It is possible to set the ignition cut maximum level, that is the percentage of ignition events cut to keep the engine under the rev limiter.

The RPM progression range acts as a smoothing for ignition cut. Example: rev limiter at 8000rpm, RPM progression range at 200rpm. From 8000rpm the ignition cut level will gradually increase until it reaches 90% cut at 8200rpm.

Percentages less than 90% may not keep the engine under the rev limiter. Bigger RPM progression range tend to stabilize more smoothly the rev limiter, but allows the RPM to pass the RPM set as rev limiter. These numbers are valid to all kinds of ignition cut, with the exception of time based compensations (time based RPM and driveshaft RPM/wheel speed) and 2-step. These features have their own parameters. For inductive ignition systems it is recommended to use 90% maximum level and 200 RPM progression range. For capacitive system, like MSD, it is recommended to use 100% maximum level and 1 RPM progression range.

The "Start compensation X RPM before" helps to spool the turbo and have a more stable rev limiter.

The minimum TPS to activate timing retard and fuel enrichment allows the driver to hold the engine in the rev limiter without any compensation when not needed.

The time based compensations will only work after the release of a valid 2-step. This means hold the 2-step button with more than 50% TPS or reach the rev limiter on time at least.

2-Step warning LEDs

- 2-step without valid launch condition:** Yellow
- 2-step with valid launch condition (ign cut or TPS):** Green
- Invalid launch:** Red blinking for 5 seconds
- Valid Launch:** LED is turned off (it would be green until a valid launch)
- 2-step + staging control:** Blue
- Staging control button without 2-step:** Purple
- 2-Step + 3-Step auto:** White

Active function tables

The following tables show what will be the active function with the 2-step and 3-step combinations

2-Step: Button	3-Step: Button	Active function
Button 2-step	Button 3-step	Active function
Pressed	Pressed	3-step
Pressed	Released	2-step
Released	Pressed	3-step

2-Step: Button	3-Step: Auto	Active function
Button 2-step	MAP pressure	Active function
Pressed	Lower than target	3-step
Pressed	Higher than target	2-step

2-Step: Speed	3-Step: Button	
Speed	Button 3-step	Active function
Lower than target	Released	2-step
Lower than target	Pressed	3-step
Higher than target	Pressed	3-step

2-Step: Speed	3-Step: Auto	
Speed	MAP pressure	Active function
Lower than target	Lower than target	3-step
Lower than target	Higher than target	2-step

2-Step: Sensor	3-Step: Button	
Sensor	Button 3-step	Active function
Active condition	Released	2-step
Active condition	Pressed	3-step
Not Active condition	Pressed	3-step

2-Step: Sensor	3-Step: Auto	
Sensor	Button 3-step	Active function
Active condition	Lower than target	3-step
Active condition	Higher than target	2-step

2-Step: CAN	3-Step: Button	
Button 2-step CAN	Button 3-step	Active function
Pressed	Pressed	3-step
Pressed	Released	2-step
Released	Pressed	3-step

2-Step: CAN	3-Step: Auto	
Button 2-step CAN	MAP pressure	Active function
Pressed	Lower than target	3-step
Pressed	Higher than target	2-step

When pressing the two-step button, usually installed on the steering wheel or driven by a launch control / transbrake switch, the system activates an ignition cut in a programmable RPM.

In the FTManager, this setup is at "Sensors and calibration" - "Inputs"

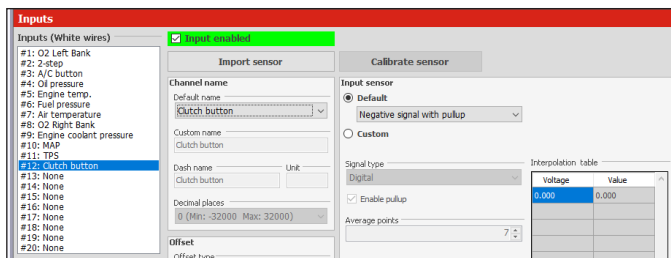

Clutch switch: for drag racing vehicles with manual transmission and clutch, this switch tells the ECU whenever the pedal is pressed. Connected to a white input.

This is an auxiliary feature to the 2-step and it helps releasing the 2-step at the same moment the clutch is being released.

If the clutch switch is pressed when the 2-step is deactivated, nothing happens, but, if the 2-step is active, then the clutch switch will hold the 2-step enabled until the clutch is released. The 2-step button

can be released after this that the 2-step feature will still be active. The 2-step button still works as usual. The clutch switch is fully optional.

Clutch switch electrical diagram

Connect the clutch switch to any white input and setup this input through the FTManager or through the screen. The other side of the clutch switch must be connected to the battery negative or chassis.

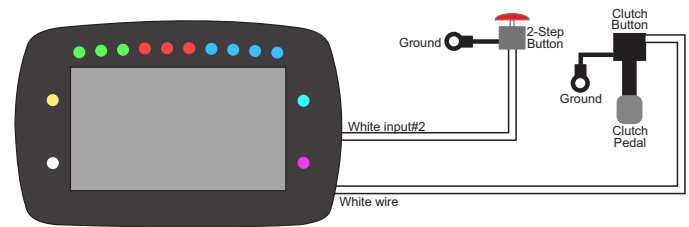

Line lock

Use a yellow output to control the line lock solenoid and setup this output as Line Lock through the FTManager or the screen. The other side of the solenoid must be connected to the battery negative or chassis.

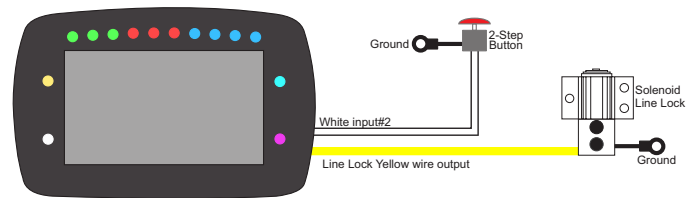

20.4 Linelock Brake Control

This function allows the use of a line lock solenoid to keep the brake line of the trailing wheels pressurized and to facilitate the exit, avoiding that the pilot has to modulate the brake with the foot at the time of the exit. For correct use of this function press the brake pedal, operate the 2-step, release the brake pedal and the line lock will be activated. When you release the 2-step, the Line Lock solenoid is automatically disabled.

Select whether to activate the line lock on burnout, 3-step and / or 2-step modes.

An output must be configured as "Output line lock".

Brake pressure control: This function enables brake pressure control through a PWM curve. This is used to lower the brake line pressure to a desired value and standardize the launches.

It is necessary to have a white input must be setup as "Brake pressure" connected to a 1500psi pressure sensor.

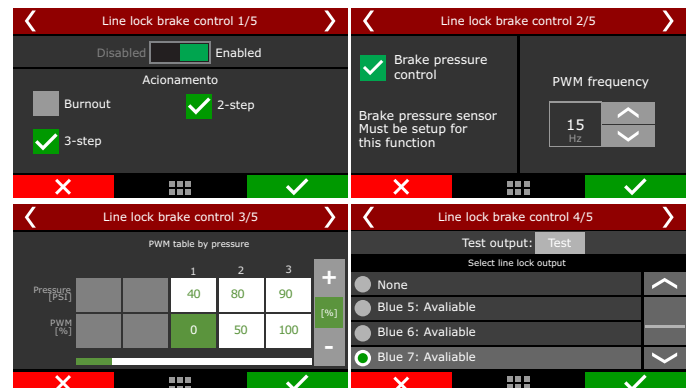

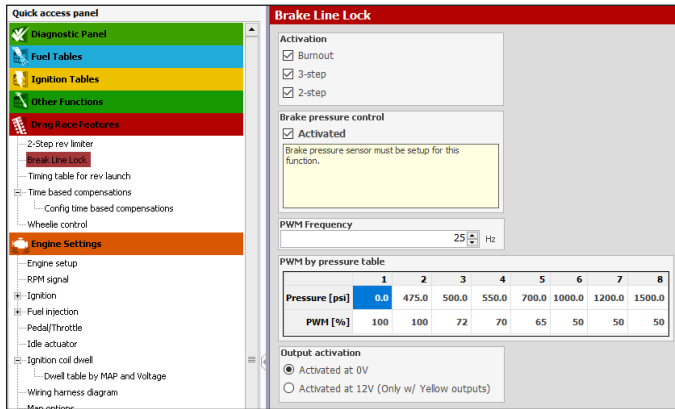
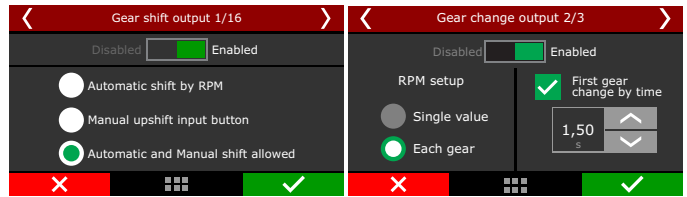
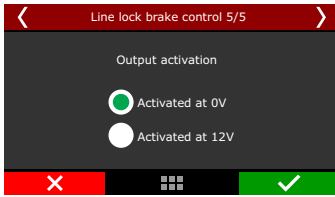

Select the desired output, all the outputs will be displayed, except the ones used for injection and ignition. In the FTManager, this setup is at "Sensors and calibration" - "Inputs".

The gear shift by single value sends a signal every time the engine reaches the selected RPM. When using the each gear mode, each gear shift will be on its own RPM. To use this mode the gear detection must be activated.

The gear shift is enabled after the 2-step is released, so, after the last gear the 2-step must be activated again to perform the shifts again. When selecting this mode, the "First gear shift by time and RPM" will be available. It allows the gear shift to be performed not only by RPM, but also by time. This means that there are 2 conditions (time and RPM) to be met to gear shift. It is not possible to use this control with automatic transmissions with more than one solenoid.

20.5 Timing table for rev launch

This timing table is only used for burnout mode, 2-step and 3-step. This is not a compensation table, but a table with absolute timing values, which ignores any other timing table or compensation.

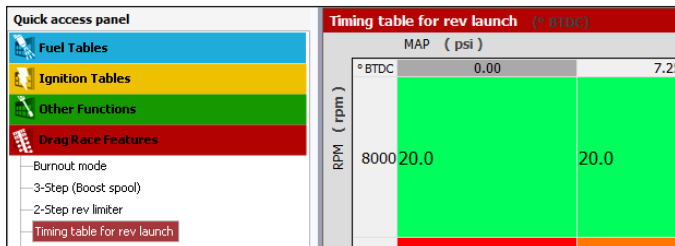

These settings will define the lock time between shifts and the RPM in which they will happen. When the engine reaches the set RPM, the output will be activated and it will start counting the lock time. The shift into next gear will only happen after this time has passed and the engine reaches the defined RPM again.

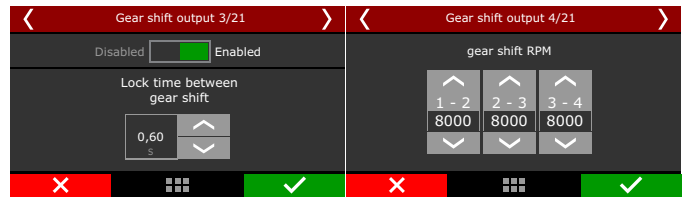

20.6 Gear shift output

This feature allows switching on an external solenoid to shift the gears. The activation strategy can be either by a fixed RPM value for all the gears or different RPM for each gear just like the shift light feature.

It's possible to enable a power reduction during gear shifts, by setting its duration, ignition timing and maximum ignition cut percentage.

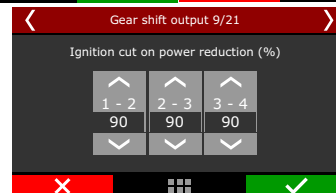
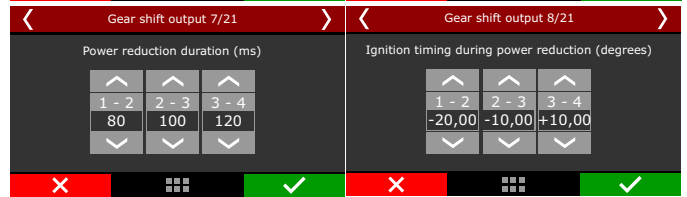
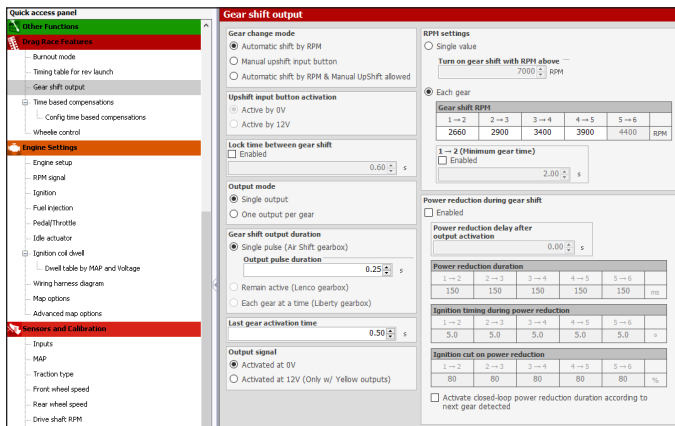

This option enables a “variable duration” in the power reduction applied in the powershift feature, it will halt the power reduction as soon as it detects the shift into the next gear.

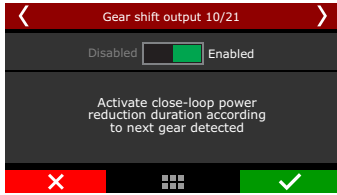

Select the outputs that will be used to activate the shifting solenoid, and the type of signal, single pulse (air shifter), remain active (Lenco) or one output at a time (Liberty).

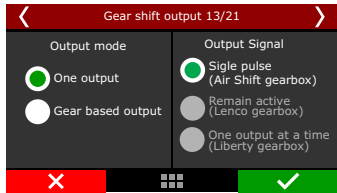

Select the desired output, all the outputs will be displayed, except the ones used for injection and ignition. In the FTManager, this setup is at “Sensors and calibration” - “Outputs”.

20.7 Time based fuel enrichment

Enables a time based fuel compensation that starts after the 2-step deactivation. This compensation is a time (seconds) versus compensation (%) feature. After you enter the table, a graph will be displayed.

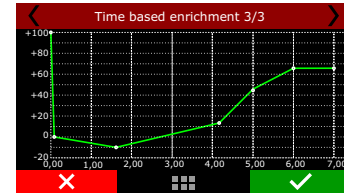

Time based revolution limiter

The RPM control is based on seven RPM and time points that can be determined as shown in the image above.

This function is frequently used in drag racing cars, because it makes it easier to control the vehicle, once it allows the traction to be recovered through an ignition cut ramp.

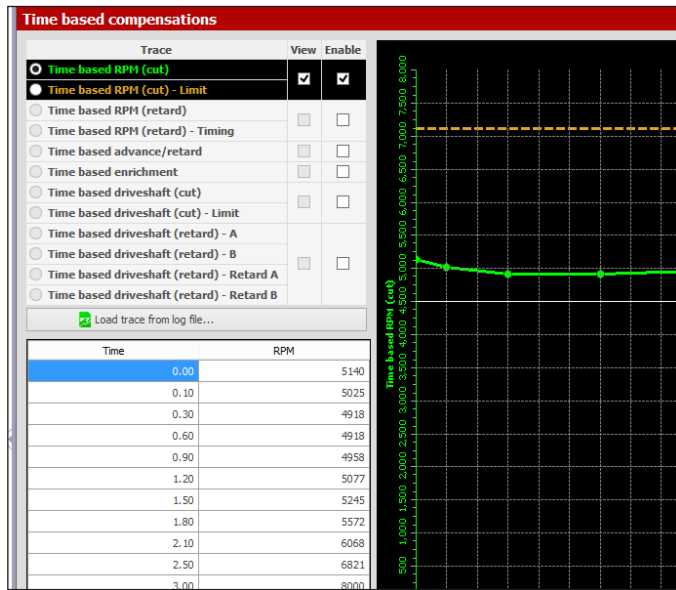
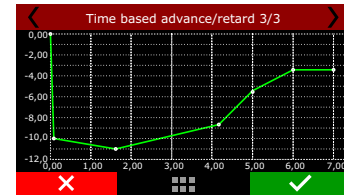
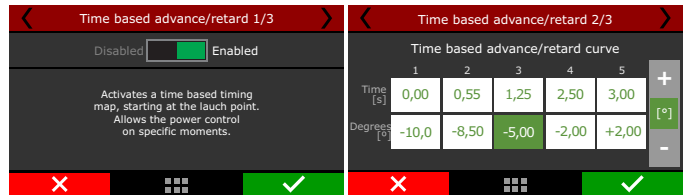

Time based speed (cut)

This feature is the same as the time based RPM (cut) but instead of using the engine RPM, it uses the wheel speed or the driveshaft RPM.

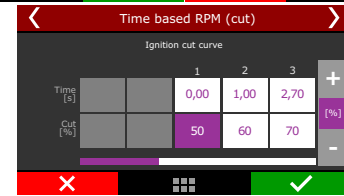

Time based advanced/retard timing

Enables a time based timing compensation that starts after the 2-step deactivation. This compensation is a time (seconds) versus degrees BTDC (° BTDC) feature. After you enter the table, a graph will be displayed.

It will perform ignition cut to keep the wheel speed/driveshaft RPM under a predefined curve.

The “Time based RPM (cut) - Limit” is the maximum level, which means the percentage of ignition events that will be cut to keep the engine under the rev limiter.

The RPM progression range acts as a smoothing for ignition cut.

Example: rev limiter at 8000rpm, RPM progression range at 200rpm. From 8000rpm the ignition cut level will gradually increase until it reaches 90% cut at 8200rpm.

Values less than 90% may not keep the engine under the rev limiter. Bigger RPM progression ranges tend to stabilize more smoothly the rev limiter, but allows the RPM to pass the RPM set as your rev limit. For inductive ignition systems it is recommended to use 90% maximum level and 200 RPM progression range. For capacitive system, like MSD, it is recommended to use 100% maximum level and 1 RPM progression range.

The last screen will show the graph.

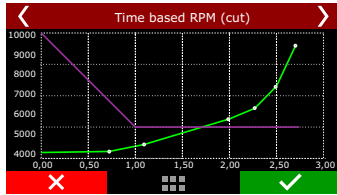

Time based RPM (retard)

This feature is very similar to the time base RPM (cut), instead of cutting the ignition, it will retard the timing, to have a smoother way to control power and torque to the wheels. The function starts after 2-step.

It is recommended to use this function together with the Time based RPM (cut) to have a better control of the engine, this way the control itself will be smoother.

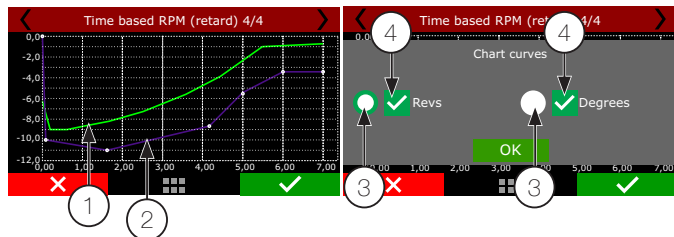
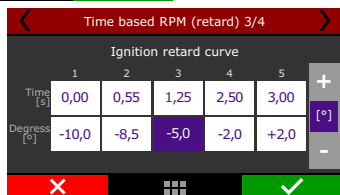
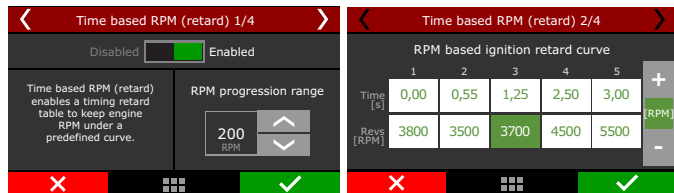

- 1 - Green Speed curve;
- 2 - Purple speed curve;
- 3 - Buttons for chart selection that will be in the upper layer;
- 4 - Check boxes to enable or disable graphic display;

Time based speed (cut)

This feature is the same as the time based RPM (cut) but instead of using the engine RPM, it uses the wheel speed (with a wheel speed sensor or by calculating speed) or the driveshaft RPM. It will

perform ignition cut to keep the wheel speed/driveshaft RPM under a predefined curve. Generally speaking, this speed/RPM control seeks to limit the wheel speed during the run.

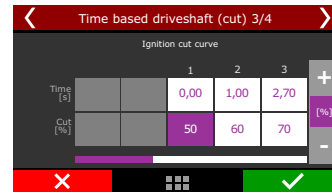

The first screen will briefly explain how the feature works and it will ask what the speed reference is, if it is a wheel speed or drive shaft RPM. You must have a wheel speed sensor or a driveshaft RPM sensor enabled to use this feature.

The first parameter to be set is the speed/RPM progression range, which is the Speed/RPM range from start the ignition cut to its maximum level.

A 10 Mph speed progression range means that if your control starts at 80 Mph, the ignition cut maximum level will be at 90 Mph.

The next screen is the wheel speed/driveshaft RPM versus time table. After the 2-step, every time the speed/RPM goes above the curve, the ECU will perform ignition cuts.

Percentages less than 90% may not keep the engine under the rev limiter. Bigger RPM progression range tend to stabilize more smoothly the rev limiter, but allows the RPM to pass the RPM set as rev limiter.

For inductive ignition systems it is recommended to use 90% maximum level and 200 RPM progression range. For capacitive system, like MSD, it is recommended to use 100% maximum level and 1 RPM progression range.

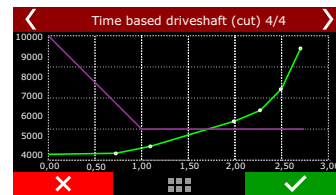

Time based speed (retard)

This feature reads the wheel speed (or the driveshaft RPM) and applies ignition compensation, according to the two RPM curves (A and B) to control launch.

The basic idea is to retard the ignition timing, reducing power to the wheels. When the wheel speed reaches the programmed in the "speed curve A", the ECU starts the programmed retard in the "delay curve A point".

As the speed increases, and goes toward the curve "B" speed, the retard applied to the timing (that is interpolated between the two retard

curves) is incremented. Thus, if the initial retard made by curve A is not sufficient to hold the speed of the vehicle, the retard will increase as much as the RPM increase.

In cases where the speed/RPM exceeds the limits of the curve "B", the maximum retard (entered in curve B) will be applied.

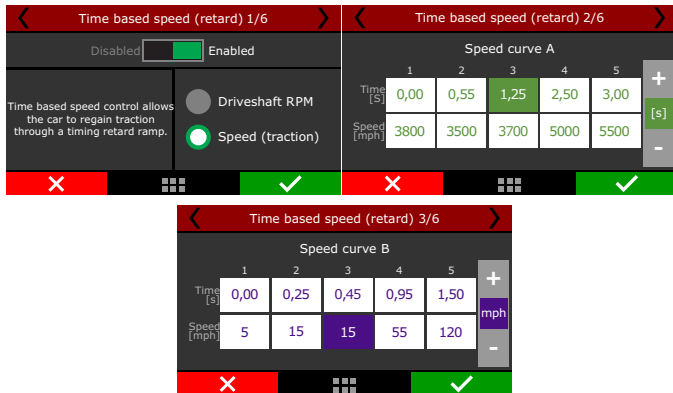

The first screen allows to select the speed/RPM reference (wheel speed or driveshaft RPM). You must have a wheel speed sensor or a driveshaft RPM sensor enabled.

The next screens will show the speed/RPM curves A and B.

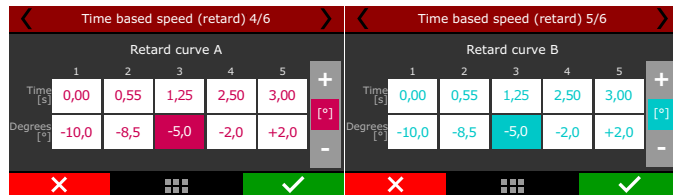

After this, the ignition retard curves A and B

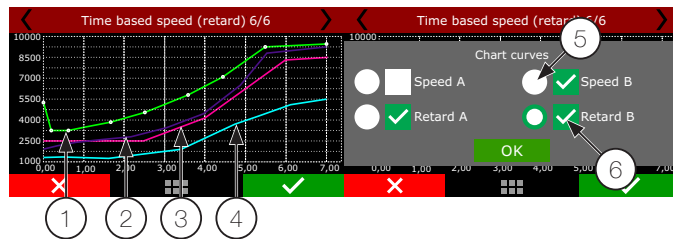

- 1 - Green speed curve A;
- 2 - Purple speed curve B;
- 3 - Pink timing retard curve A;
- 4 - Blue timing retard curve B;
- 5 - Buttons for chart selection that will be in the upper layer;
- 6 - Check boxes to enable or disable graphic display;

In the end, a graph will be displayed with all the curves (speed/RPM A and B, retard A and B)

Note that the speed and retard curves shown on the graph form speed and retard zones. They have the following characteristics:

- When below the curve A, there is no retard applied to the engine;
- When the speed/RPM is equal to the programmed curve A, the ignition retard is equal to the programmed in curve A;
- For speed/RPM between the two curves, the retard is interpolated, in other words, the more the speed/RPM exceeds the curve A towards to curve B, the more retarded the timing will be;

- If the speed/RPM programmed is overcoming the curve B, the ignition retard is equal to the value programmed in curve B.

20.8 Pro-Nitrous

This feature controls up to 6 time based nitrous stages, with individual settings for each stage.

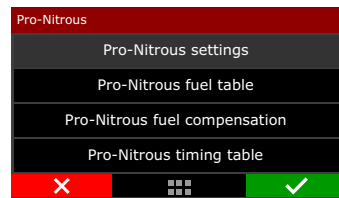
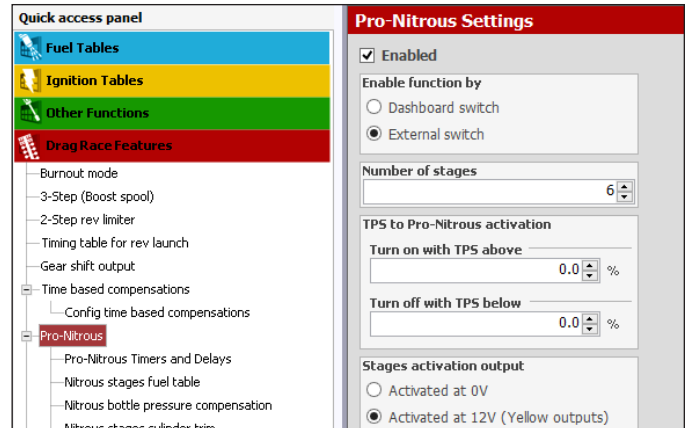

Pro-Nitrous settings

To activate the Pro-Nitrous it is mandatory fulfill 3 requirements:

1. Active the Pro-Nitrous button (external switch in one of the white inputs or a dashboard button in FT display).
2. The elapsed time after 2-step cannot be more than 15s, otherwise Pro-Nitrous will not be turned on. In other words, the vehicle must launch in less than 15s after 2-step deactivation.
3. TPS must be above minimum percentage configured.

With these 3 requirements fulfilled, the Pro-Nitrous stages will start and follow the configured time. The fuel and timing compensations will also start at this point. If any condition fails, the Pro-Nitrous is deactivated and FT will use fuel, timing and O2 closed loop main tables.

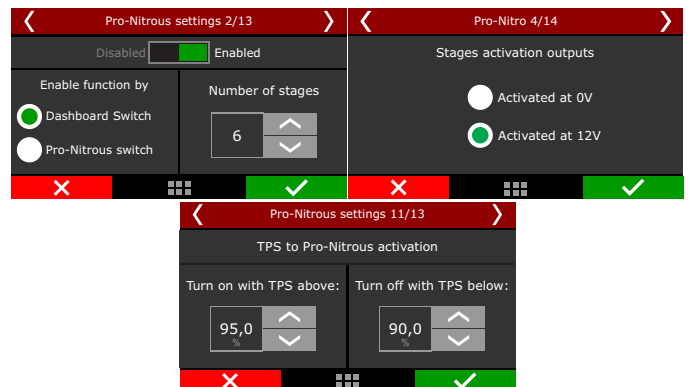

The first parameter to be set is the enabling mode:

- **Dashboard button:** a touchscreen button in the LCD screen that can be found in the Dashboard settings menu.
- **External switch:** a white input must be used with an external switch. While the input is grounded, the Pro-Nitrous will be on.

FuelTech FT allows firing the solenoids by switching 12V or 0V (ground), which must be setup in the grays or yellow outputs.

All the Pro-Nitrous inputs and outputs can be set both by touchscreen or FTManager, in the "Sensor and calibration" menu.

Pro-Nitrous has two different TPS limits. One limit is to turn on with a minimum TPS, the other is to turn off with a maximum TPS. The recommend is set the TPS to turn on at least 5% higher than the TPS to turn off. This way there will be a hysteresis that won't let Pro-Nitrous turn on and turn off several times when TPS is around activation TPS. Also, you will be able to pedal the throttle to get back traction.

The RPM activation window is necessary to protect the engine, not allowing having a nitrous shot in a low RPM or by deactivating nitrous before the rev limiter

The Pro-Nitrous timers and delays table gathers the on and off settings for stages and compensations. A pedaling delay can also be set, so, if the driver pedals in a run, the Pro-Nitrous can be reactivated progressively.

In the FTManager, this table is as shown below.

Pro-Nitrous Timers and Delays						
	Stage #1	Stage #2	Stage #3	Stage #4	Stage #5	Stage #6
NOS stage timers						
ON after launch	0.00	0.00	0.00	0.00	0.00	0.00 s
OFF after launch	0.00	0.00	0.00	0.00	0.00	0.00 s
ON after pedaling	0.00	0.00	0.00	0.00	0.00	0.00 s
NOS fuel compensation						
ON delay	0.00	0.00	0.00	0.00	0.00	0.00 s
OFF delay	0.00	0.00	0.00	0.00	0.00	0.00 s
OFF ramp	0.00	0.00	0.00	0.00	0.00	0.00 s
NOS ignition timing compensation						
ON delay	0.00	0.00	0.00	0.00	0.00	0.00 s
OFF delay	0.00	0.00	0.00	0.00	0.00	0.00 s
OFF ramp	0.00	0.00	0.00	0.00	0.00	0.00 s

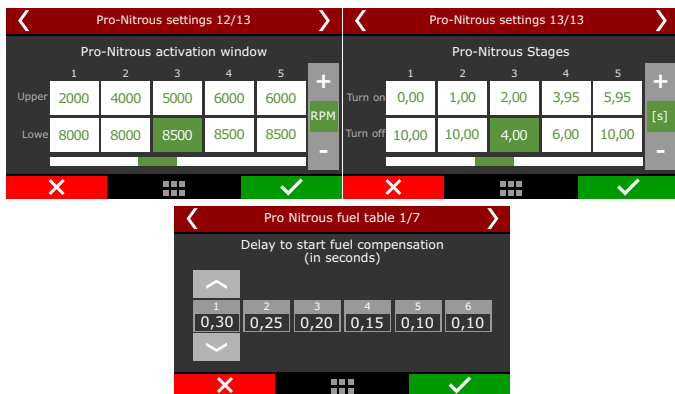

Pro-Nitrous fuel tables

Here all the fuel compensation for Pro-Nitrous can be configured according to each stage.

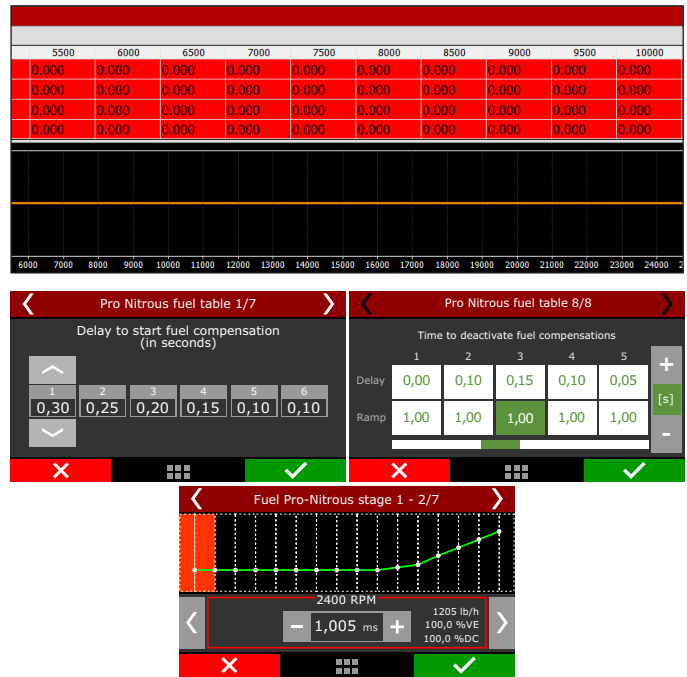

On the first screen is the configuration that allows setting a delay to start the fuel compensation, based on the time that the nitrous shot takes to get to the combustion chamber.

After the delay, there are the fuel tables to each stage. You can program the fuel compensation over RPM and it is calculated considering the main fuel table.

Since the injectors are closer to the combustion chamber than the nozzles/foggers, the purpose is that the fuel and nitrous get to the combustion chamber at the very same time.

In the FTManager software is possible to visualize the total calculated fuel table.

It is possible to set an OFF delay and OFF ramp after each stage. It helps because moments after shut down the nitrous solenoid, the intake still full of nitrous that will be consumed by the engine.

Nitrous stage cylinder trim and bottle pressure compensation

- This is a fuel injection cylinder trim for the Pro-Nitrous feature.

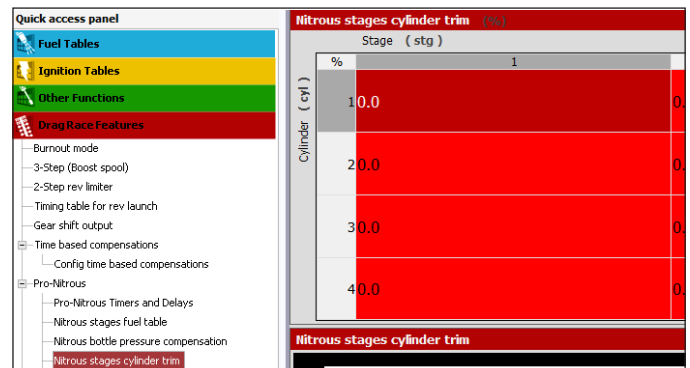



- Bottle pressure compensation:** compensates the bottle pressure drop that happens in a run. The bigger the nitrous consumption, the bigger the pressure drops, and consequently the nitrous mass is smaller. With this, less fuel is necessary.

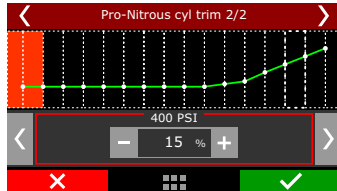

Nitrous stage timing tables: After the delay, there are the timing tables to each stage. You can program the timing compensation over RPM and it is calculated considering the main timing table. In the FTManager software is possible to visualize the total calculated ignition table.

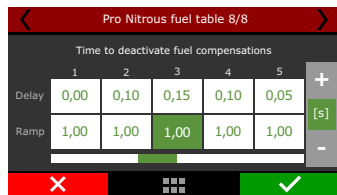
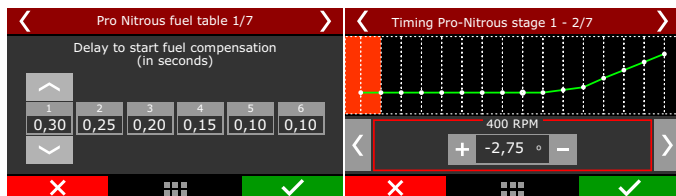
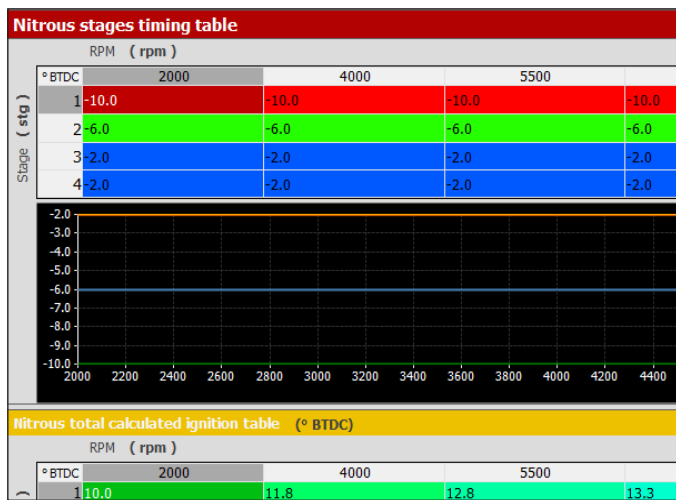

20.9 Time based output

This feature allows activating an auxiliary output by time, which can be used to release the parachute, turn on the nitrous or even switch on the torque converter lockup solenoid.

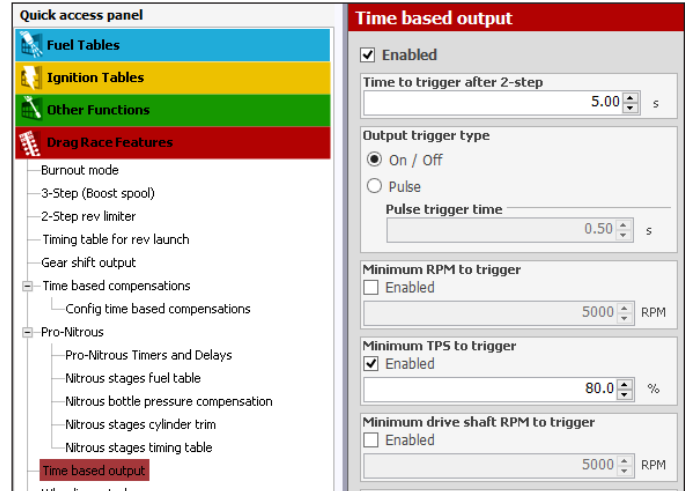

Also, there are conditions, besides time, to trigger the output. The conditions are: minimum RPM, minimum TPS, minimum driveshaft RPM and minimum wheel speed.

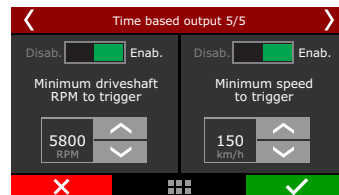
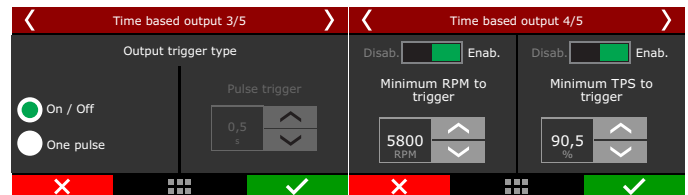

All these options can be enabled or disabled. The output signal can be an ON/OFF signal (remaining on while the conditions are valid) or a pulse (to release the parachute, for instance), which the duration is programmable.

The available activation conditions are: minimum RPM, minimum TPS, minimum driveshaft RPM.

If the output trigger type is ON/OFF, when one of the conditions stops being met, the output is turned off.

When activated, the output switches to 0V. In the FTManager, select the output in the "Sensors and calibration" menu, then "Outputs".

20.10 Wheelie Control

This function reads height and pitch sensors to help prevent the from leaving the track surface. It is recommended for rear wheel drive cars and bikes.

Wheele control

Mode
 Always active
 Drag racing only

Retard stage
 Enabled
The Retard stage of wheelee control can be enabled based on laser height sensor installed on the front of the car and/or a Pitch rate sensor, that when reached will retard the ignition timing trying to reduce wheelee and activating an output if configured.

Cut stage
 Enabled
The Cut stage of wheelee control will be activated if height and/or pitch rate keeps increasing by proceeding an ignition cut at a 90° level and activating an output.

Ride height for timing retard stage
 Enabled
 11.0 in

Ride height for cut stage
 Enabled
 15.0 in

Pitch rate for timing retard stage
 Enabled
 0.0 %/s

Pitch rate for cut stage
 Enabled
 0.0 %/s

Timing retard
 -20.0 °

Minimum cut duration
 2.0 s

Wheele control

Retard stage

Cut stage

Retard Stage

This feature retards the ignition timing when the front of the car reaches the limit height that has been programmed. The cut stage cuts the ignition to control the front height of the vehicle. The retard stage is a first line of defense to keep the ride height under control, the cut stage is a more aggressive way to stop the height/or pitch rate from keep increasing.

Always active: As long as the engine is running this feature will be active, independent how or where the car is positioned, even when testing the car on a car lift. This function is highly recommended for motorcycles.

Wheele control 3/9

Disab. Enab.

Height for timing retard stage
 11,0 in

Disab. Enab.

Pitch rate for timing retard stage
 5,0 %/s

Timing retard
 -10,0 °

Timing return ramp
 1,00 s

Drag racing only: This feature will be activated after releasing the 2 step button/switch, during the next 15s it will be operating. Set height (in) or pitch rate (%/s) to activate the retard control. It is possible to use both sensors at the same time.

Height compensation 3/6

seconds	0,00	0,10	0,20
15,0	-0,80	-0,88	-0,75
16,0	-0,90	-1,00	-0,88
17,0	-0,88	-1,00	-0,80

Pitch rate compensation 4/6

seconds	0,00	1,00	2,00
250,0	-0,80	-0,88	-0,75
300,0	-0,90	-1,00	-0,88
350,0	-0,88	-1,00	-0,80

Cut stage

As the retarding control, there are height and pitch rate configurations to the cut stage. The cut level can be configured, and it is possible to define a minimum time to the cut occurs.

Always active: As long as the engine is running this feature will be active, independent how or where the car is positioned, even when testing the car on a car lift. This function is highly recommended for motorcycles.

Wheele control 5/9

Disab. Enab.

Height for cut stage
 15,0 in

Disab. Enab.

Pitch rate for cut stage
 1,5 %/s

Minimum cut duration
 2,00 s

Drag racing only: This feature will be activated after releasing the 2 step button/switch, during the next 15s it will be operating. Set height (in) or pitch rate (%/s) to activate the retard control. It is possible to use both sensors at the same time.

Cut by height 3/7

seconds	0,00	0,10	0,20
15,0	-0,80	-0,88	-0,75
16,0	-0,90	-1,00	-0,88
17,0	-0,88	-1,00	-0,80

Cut by pitch rate 4/7

seconds	0,00	1,00	2,00
250,0	-0,80	-0,88	-0,75
300,0	-0,90	-1,00	-0,88
350,0	-0,88	-1,00	-0,80

There is also the option to trigger an auxiliary output when the retard or cut is being performed. The output can be used to release the chute, shift gears, etc.

In the FTManager, select the output in the "Sensors and calibration" menu, then "Outputs".

To use this function, a height sensor or a pitch rate sensor must be installed and configured in the "Sensors and calibration" menu, then "Inputs".

20.11 Davis Technologies

The Davis Technologies Profiler is a traction control module, for rear wheel drive cars, which controls ignition timing and ignition cut by driveshaft RPM. This module allows direct communication with FT. In the FTManager, go to "Sensor and calibration" menu, then "Inputs" and select the white input wires that will do the communicate with the Davis Technologies Profiler.

Timing signal 1/2

Input selection
 White 1: Available
 White 2: Available
 White 3: Air temperature
 White 4: TPS

SmartDrop (TM) Signal 2/2

Input selection
 White 1: Available
 White 2: Available
 White 3: Air temperature
 White 4: TPS

20.12 Time based throttle opening

This feature creates a curve for a time based progressive opening of the electronic throttle.

Time based throttle opening 1/3

Attention!
 Electronic throttle control must be activated and correctly setup in order to use this feature.
 Ok

Time based throttle opening 1/3

Disabled Enabled

This feature allows the control of the throttle opening by time

You can create a curve based on time by maximum percentage of throttle opening.

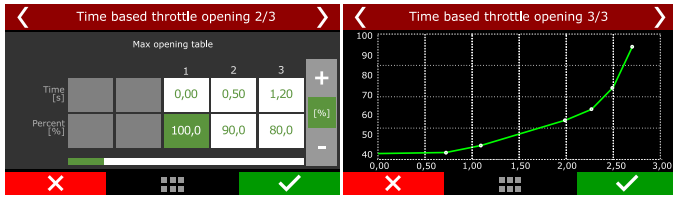

Now it is possible to select if the transbrake and the staging function will be active during 2-step and 3-step. This makes easier to stage the car and prevents the driver from trying to stage without meeting the launch conditions.

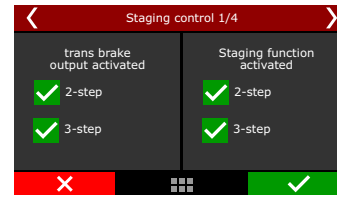

20.13 Staging control

This function helps the car alignment when pre-staging after the burnout. When activated, it's possible to control the transbrake solenoid frequency to hold the car properly.

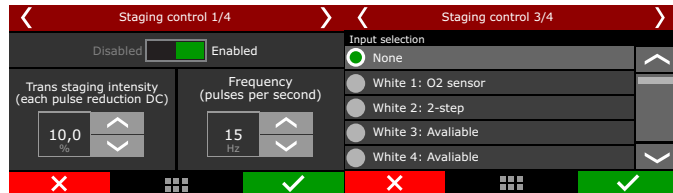

After configuring the inputs and outputs, its necessary to adjust the safety parameters, like the number of button presses to apply security, the additional intensity for security and the maximum time for output duration for solenoid protection.

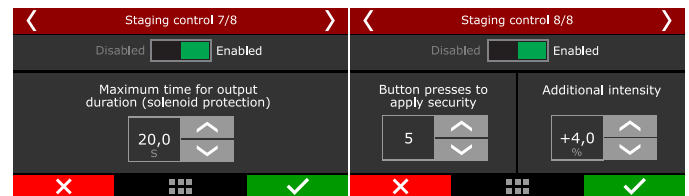

Staging control electrical diagram with Hella solid state relay

Use the diagram below to wire the staging control feature.

Any white wire can be used for the 2-step and staging buttons. The other side of the buttons must be connected to the battery negative or to a switched 12V when needed.



IMPORTANT
The use of a solid state relay is mandatory for this feature to work properly.

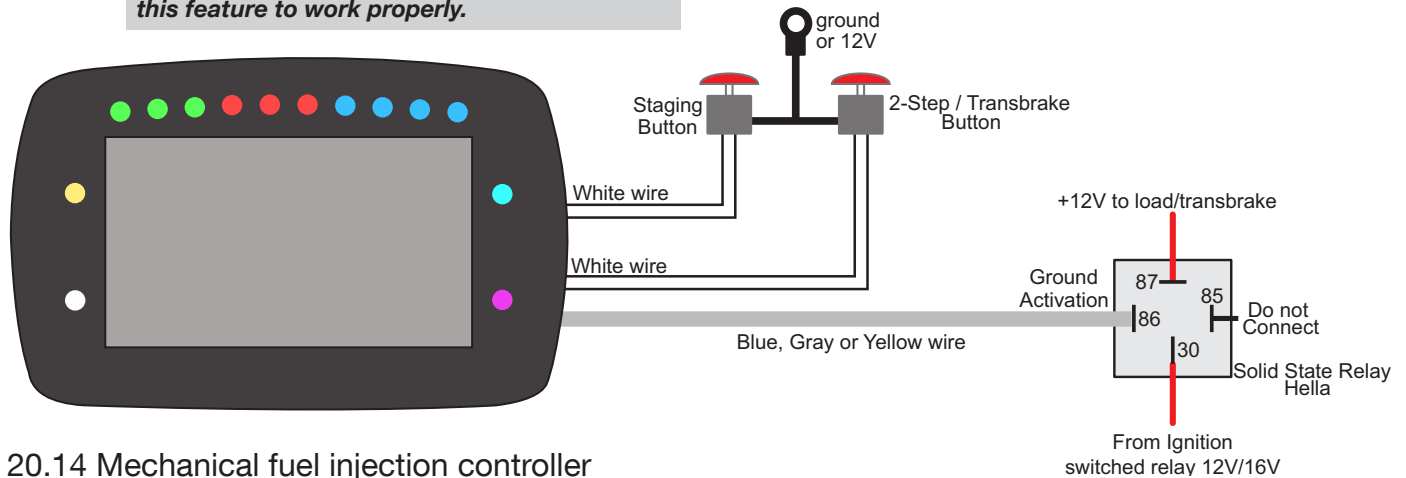

20.14 Mechanical fuel injection controller

The Mechanical Injection Fuel Controller is used to activate or deactivate solenoids that decrease the amount of fuel that goes to the engine (Lean out solenoids) in cars that use mechanical fuel injection (without fuel injectors).



NOTE
This manual shows the settings for one stage, but the same can be applied to all other stages.

Settings:

The function can be enabled by a button on the ECU dashboard, by an external switch (requires an appropriately configured analog input or always active when the ECU is switched on).

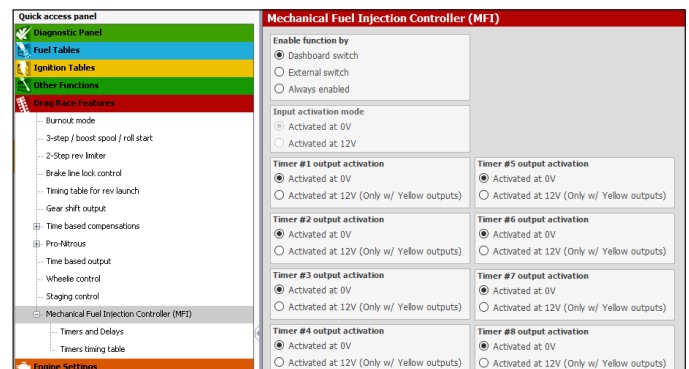

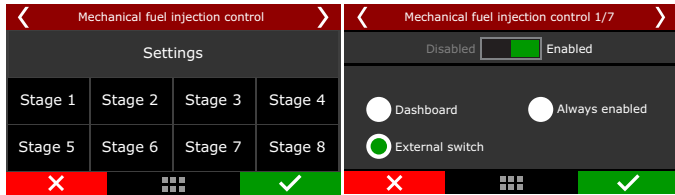

The ignition compensations for each stage can be activated or deactivated with a delay time in relation to the fuel solenoid activation time, thus seeking to get the exact time that ignition timing needs to be changed to equal the fuel difference that is going to the engine. Next set up the ignition timing on the table, it's possible to set up to 16 points for each stage.

When using an external switch, a white input must be configured or a SwitchPanel-8 button when using CAN.

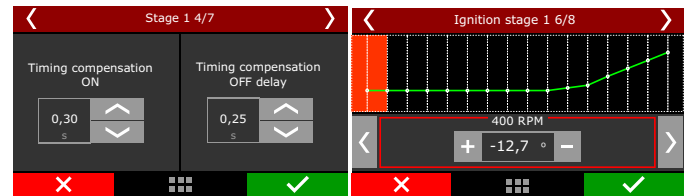
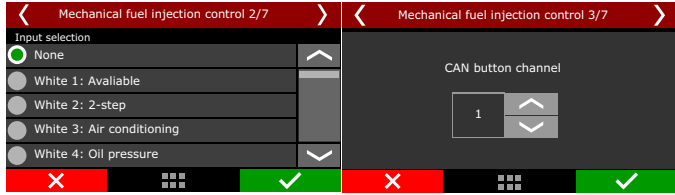

The last step is to select which output is responsible for each stage and how it activates (0v or 12v).

After that it's possible to test to see if the output is working properly by clicking on "test".

Stages

You can set up to 8 stages depending on what you need.

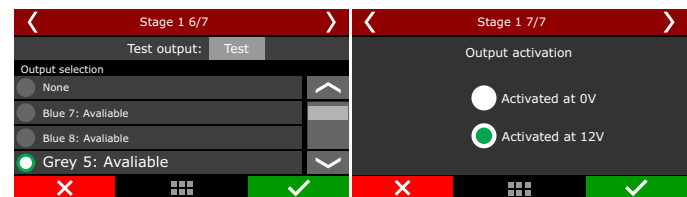
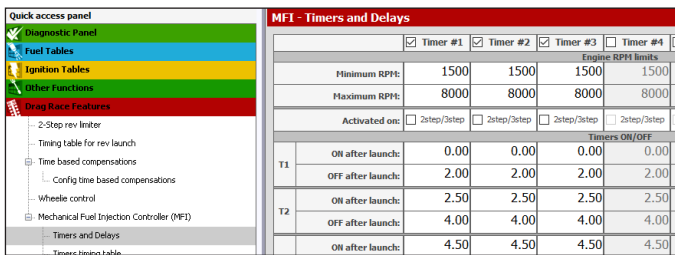

20.15 Launch delay controls (delay box)

This feature was developed for Bracket racing, in which two competitors launch at different times. There are several different delay times available for this function.

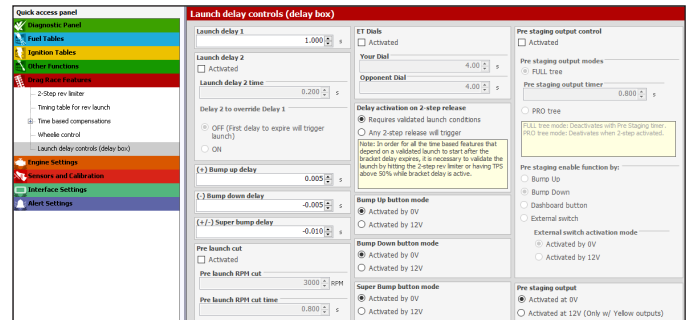
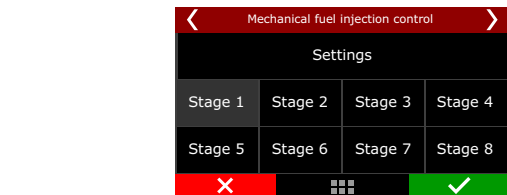

Stages can be triggered within a RPM window and/or maintain the desired stages during the 2-step and 3-step by enabling them in the check boxes

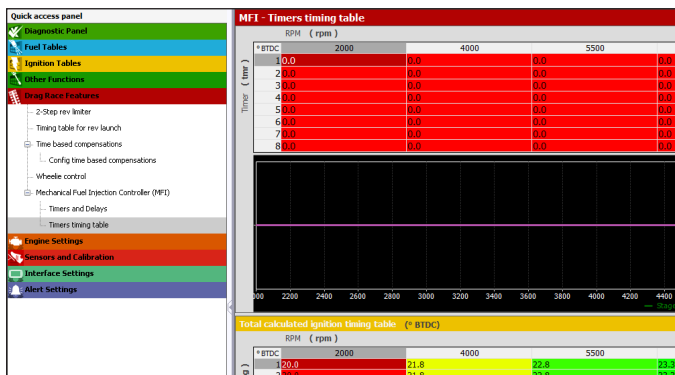

Operation mode

There are two operation modes for this function.

Launch delay only: This option adjusts the delays only according to the set up value, regardless the opponent time.

With dial on dashboard: In this option, the delays will be calculated according to the time shown on the dial.

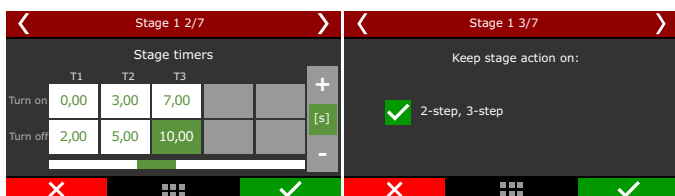
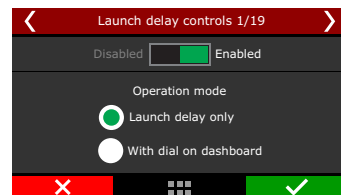
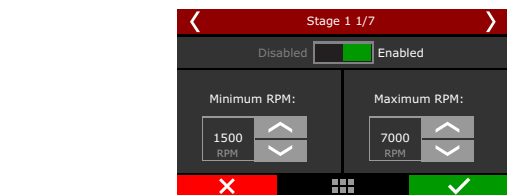

NOTE

It's necessary to configure the dials (bracket) in Interface Settings / Dashboard setup

In order for all the time based features that depend on a validated launch to start after the bracket delay expires, it's necessary to validate the launch by hitting the 2-step rev limiter or having TPS above 50% while bracket delay is active.

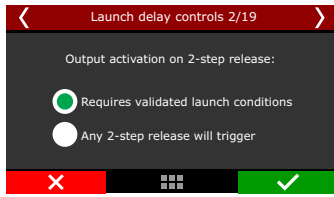

The next screens are dedicated to set up the launch delays 1 and 2. The values must be set in milliseconds.

Delay 1: Timer to launch the vehicle that begins counting down upon release of two step button.

Delay 2: Secondary delay option that allows the driver to get a second hit on the tree by pressing the two step button again after delay 1 timer has been triggered.

There are two options for this feature:

ON: Delay 2 overrides delay 1 and will launch the vehicle based on delay 2 timer once 2 step button is pressed and released for a second time.

OFF: Delay 2 DOES NOT override delay 1 and the vehicle will launch with the timer of whichever delay expires first.

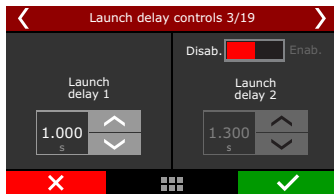

Bump Up (+): Adds a USER defined time to delay 1 in order to calculate final delay timer. The numbers in this field can only have a positive value.

Triggering Bump up multiples times before delay 1 timer expires will result in each instance being added to final delay calculation.

Bump Down (-): Subtracts a USER defined time from delay 1 to calculate final delay. The numbers in this field can only have negative values.

Triggering bump down multiple times before delay 1 timer expires will result in each instance being subtracted from final delay calculation.

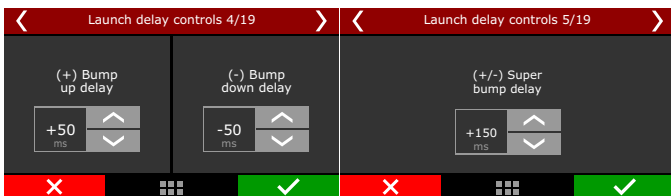

Pre launch RPM cut and Pre launch timer: This feature makes it possible to set a target RPM cut designed to "save" the engine during the staging procedure. The pre launch RPM target will be lower than the 2 step RPM target and will be active while the 2 step button is pressed. It will deactivate when a user defined pre launch timer is subtracted from an initiated delay 1 timer. (Example: 1.000 delay 1 and a 0.200 pre-launch timer will allow engine to climb to the 2-step target RPM cut at 0.800)

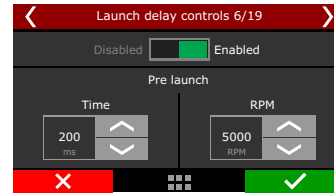

Pre staging output mode

This control modifies the behavior of launch delay, this setting is used to align the car before entering pre-staging.

There are two operating modes "FULL tree" and "PRO tree".

FULL tree mode: is activated for a configured time

PRO tree mode: is activated by a button and deactivates when the 2-step condition is met.

Select how the Pre staging will be activated. There are four options, "Bump up button", "Bump down button", "Dashboard switch" or "External button", in the latter it is necessary to configure one more input for activating the button in addition to the input for activating the function.

It is possible to reset the delays by pressing the button again before the set time is reached.

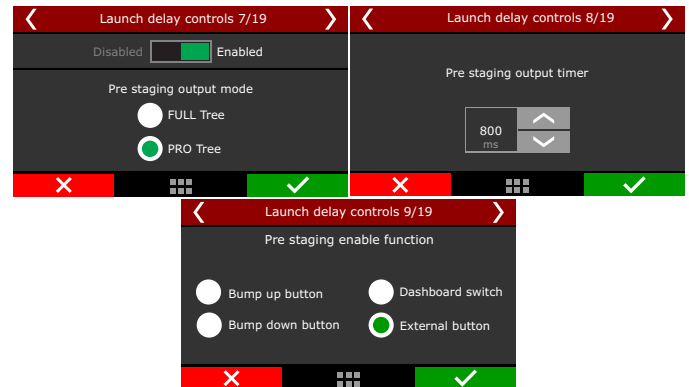

Inputs and Output

Inputs: There are 3 inputs that can be configured. *Bump up* button, *bump down* button and *super bump* button. These buttons can be connected to the analog inputs (white wires) or configured on a SwitchPanel via CAN network.

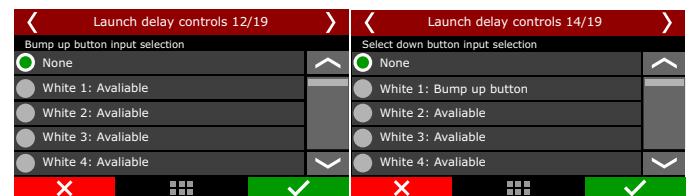

Output: This feature makes it possible to configure an output that will trigger a solenoid to limit the engine air intake opening. This output remains active while two step button is pressed and deactivates when the pre launch timer expires.

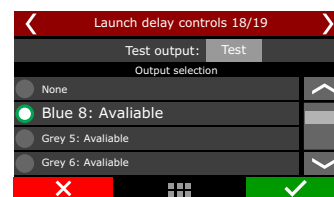

20.16 Time based individual ignition trim

Time based individual ignition trim table after validated launch, allowing better engine power management.

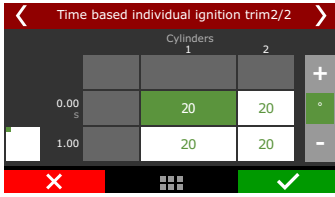

20.17 Time based individual fuel trim

Time based individual fuel trim table after validated launch, allowing better fuel management.

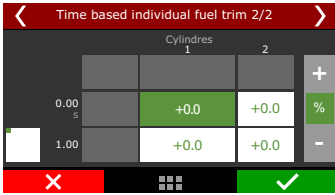

20.18 DialBoard

Adjusts the time to be displayed on the car's external panel (DialBoard).

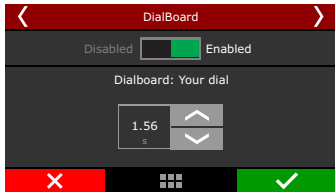

20.19 Throttle stop control

This function allows blocking the throttle for a setup time. The total blocking time is "Timer 2 (OFF) - Timer 1 (ON)".

It's also possible to configure buttons to increase or decrease this delay.

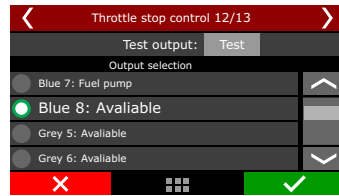
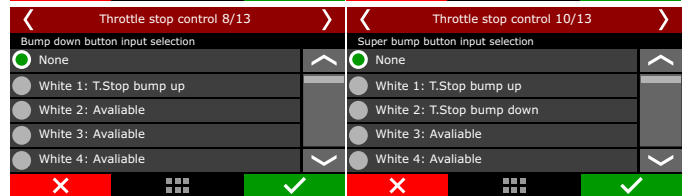
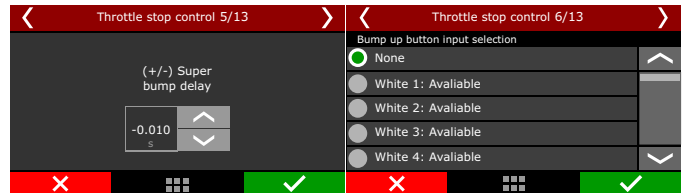
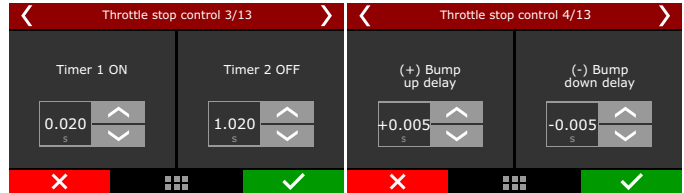
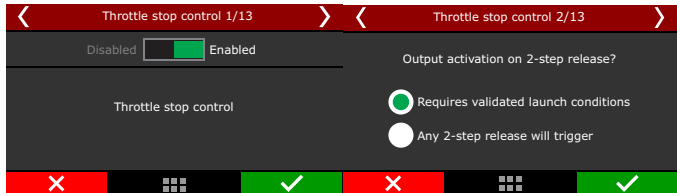
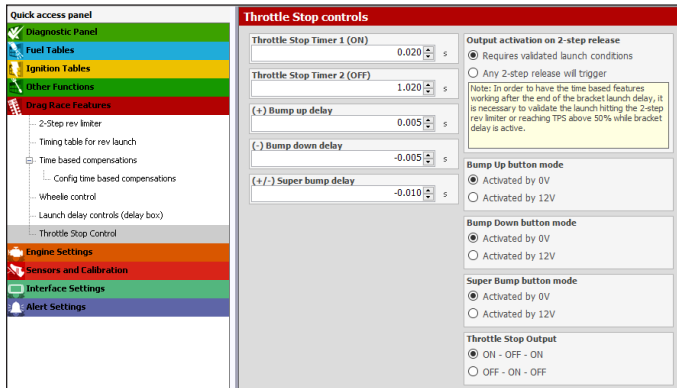

Choose how the throttle stop will be triggered within the function.

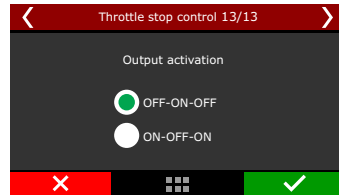

21. Alert settings

This is the menu where you can set all the alert warnings, including safety mode and engine shut down.

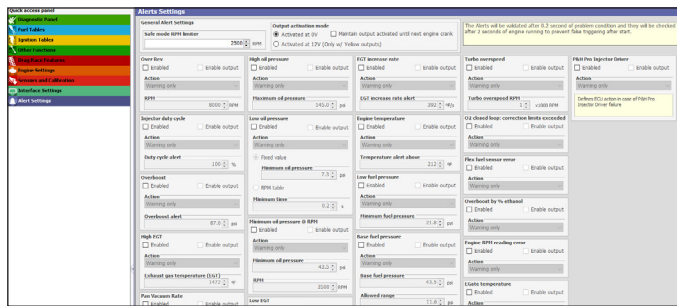

21.1 General alert settings

Safe mode protects the engine whenever an alert is activated, limiting max engine RPM while the alert condition is still happening.

It is also possible to configure an "alert" output so that when an alert condition is met, the output will be triggered automatically. By checking the "Maintain output activated until next engine crank" the ECU will remain in safe mode until the engine is started again.

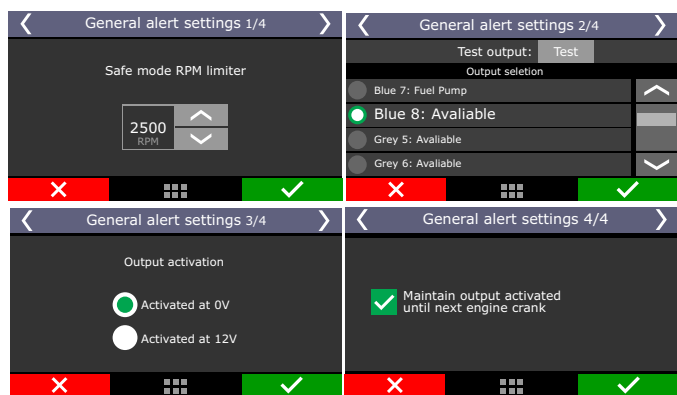

21.2 Alerts

The configuration of alerts allows the programming of sound and visual alerts whenever a dangerous situation to the engine is detected. It is possible to setup up to three different actions when any alert is displayed on the screen:

Alert only: alert is displayed on the screen, but the engine continues to work normally.

Safe mode: besides the alert displaying on the screen, engine has its max RPM limited to what was set up on the "Safe mode rev limiter" parameter

Engine shut off: besides the alert displayed on the screen, engine is immediately shut off by fuel and ignition cut.



NOTE

Keep in mind that the alerts programmed here can happen at any time, including during overtakes, turns, passes at the track and on the dynamometer. Be careful when selecting the "turn engine off" option and use it only for vital engine alerts.

Over rev

Setup the RPM for alert and the action the ECU must perform.

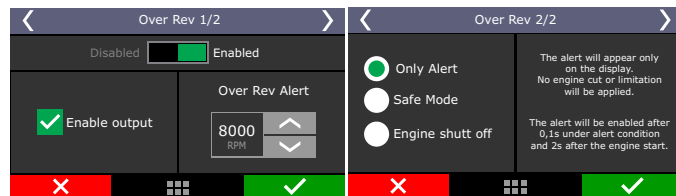

Overboost

Setup an overboost value to activate the alert and the action the ECU must perform.



Engine temperature

Setup an engine temperature to activate the alert and the action the ECU must perform.

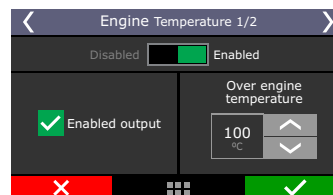

Injector duty cycle

Setup a percentage value that indicates injector's saturation.

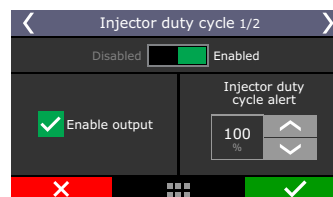

Oil Pressure

Enter a value that would be considered as excessive oil pressure excess and one that's considered for low oil pressure. Also, select how the ECU reacts when this alert is activated.

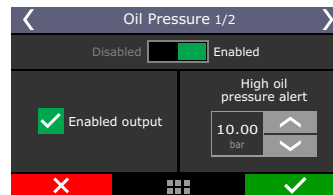

Low oil pressure

It creates an alert for low oil pressure, which can be configured with a single value or through a pressure per RPM table.

Adjust the minimum condition time for the alert to trigger.



Minimum oil pressure

Setup a minimum oil pressure value above X RPM and how the ECU reacts.

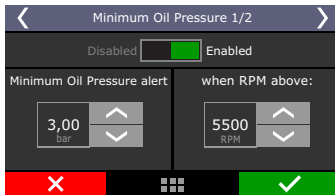

Low fuel pressure

Setup a value to activate the alert and how the ECU reacts.

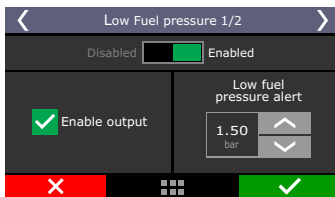

Base fuel pressure

Setup here a tolerance for the base fuel pressure.

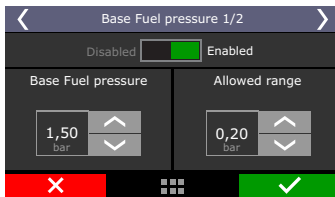

The base fuel pressure is what the pressure regulator should keep with MAP = 0 psi, that, in most of cases is 45psi with the engine turned off and the fuel pump turned on.

When engine is turned on, the vacuum/boost makes the fuel pressure regulator to manage the fuel pressure in a 1:1 ratio.

Example: an engine idling with -8.7psi of map pressure must have 34.8psi of fuel pressure if differential pressure is set as 43.5psi. If the MAP sensor is reading 29psi, the fuel pressure must be 72.5psi. If the tolerance range is 5.8psi, the differential pressure can vary from 37.7 psi to 49.3psi.

High exhaust gas temperature alert (EGT)

Set the high exhaust gas temperature value for alert and the alert type as: "Alert only" "Safe mode" or "Engine shut off".



NOTE
This function only works for EGT probes reading a single cylinder. EGTs for the entire bank or a single EGT for the motor are not considered for this alert.

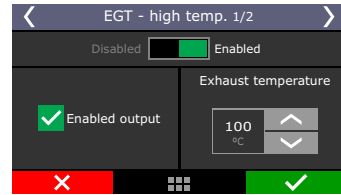

Low exhaust gas temperature alert (EGT)

Set the low exhaust gas temperature value for alert and the alert type as: "Alert only" "Safe mode" or "Engine shut off"



NOTE
This function only works for EGT probes reading a single cylinder. EGTs for the entire bank or a single EGT for the motor are not considered for this alert.

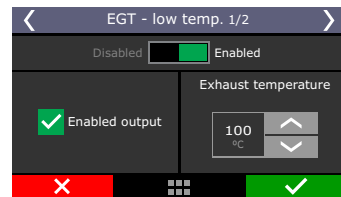

O2 closed loop Correction limits exceeded

An alert will show when the O2 correction reaches upper or lower limits configured in the map.

Flex fuel sensor error

In cases where the sensor has read problems or is disconnected, alert will be displayed, the engine will enter safe mode or switch off.

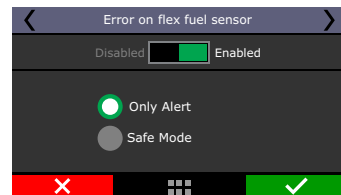

Overboost by % ethanol

It is possible to enable overboost alert according to the amount of ethanol used. When you select this alert, a table is available in the alerts settings menu.

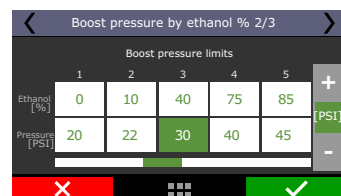

Engine RPM reading error

This alert is activated when RPM reading shows an error, the ECU goes to safe mode, dashboard alert or engine shutoff.

Turbo overspeed

This alert is related to the turbo speed sensor, allowing configuration of dashboard warning, safe mode or engine shutoff.

Pan vacuum rate

This alert comes on when the rate of pan vacuum reading exceed the threshold configured, indicating an imminent problem in the engine.

EGT increase rate

Alert for EGT reading variation, indicating some of the cylinders can be under dangerous situation.

eGate Temperature

Setup an eGate temperature to activate the alert and the action the ECU must perform.

Peak and Hold PRO Injector Driver

This alert is activated when an error occurs in the P&H Pro Injector Driver

Alerts for electrified vehicles

There are a number of alerts that can be configured for electrified vehicles, to activate them, access the "Alerts Settings" menu. These alerts have the same actions as the alerts for combustion engines.

22. Favorites

In this menu it is possible to have access to the most used functions of the ECU. It gives quick access to functions as:

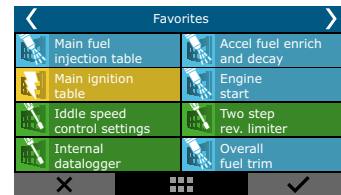

23. Interface settings

Here are the settings related to the interface like measure units, buzzer sound, LCD backlight, etc.

23.1 Day/night mode selection

There are 4 options to select.

Day mode: adjust brightness the display to value in LCD backlight settings menu.

Night mode: adjust brightness the display to value in LCD backlight settings menu.

Dashboard: Enable button on dash to control mode.

Day/night external switch: this option is necessary configure a white input with vehicle light switch.

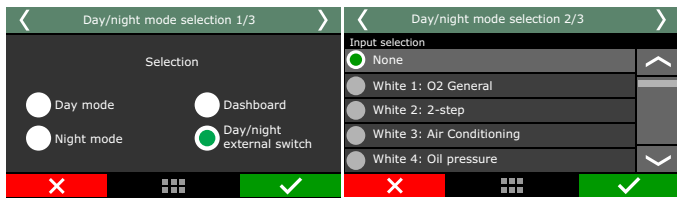

23.2 LCD backlight settings (FT600 only)

Adjust LCD brightness and select between night and day modes.

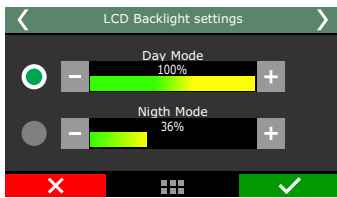

23.3 LED configuration (FT600 only)

This function allows you to configure all optional LED's

LED bar

Select here the options on how the shift light LEDs will work. It is possible to set the LEDs to turn on in a fixed RPM, progressively or with different values by gear.

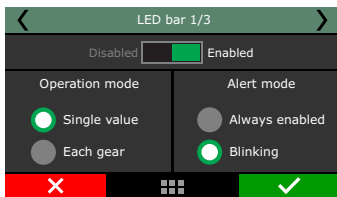

Single value: select the LED you want to edit, choose its color and the RPM value to activate it .

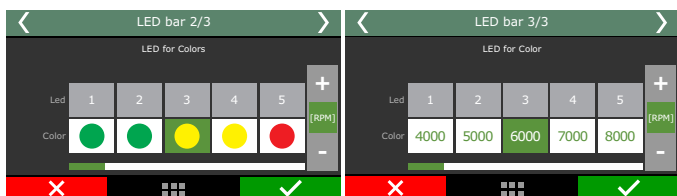

By gear: select the LED to edit, choose its color, set the RPM you want it to turn on for each gear and which LEDs will be activated.

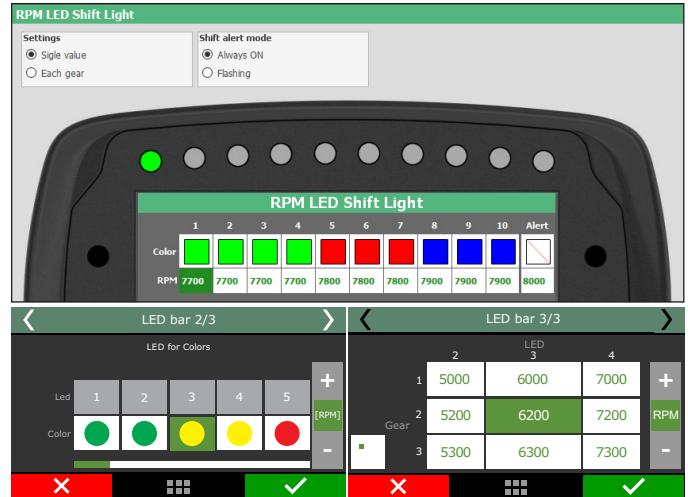

Side LEDs

It is possible to set side LEDs choosing from up to 52 alerts options.

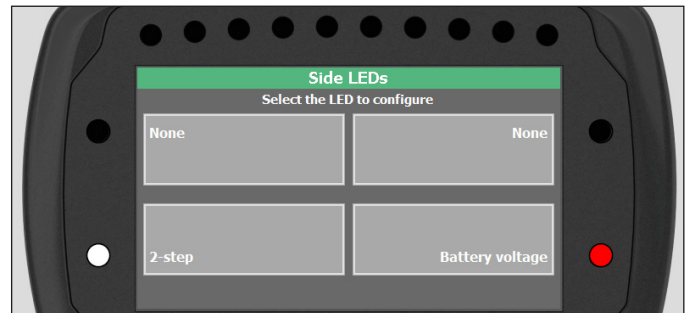

Color: Select the LED color.

Warning mode: This menu has two options; always enabled or blinking;

Condition: Select the function will be associated to this LED.

Activation mode: set the maximum and minimum values to turn the LED on.

Operation 2 and 3: This option provides more activation conditions to the same LED.

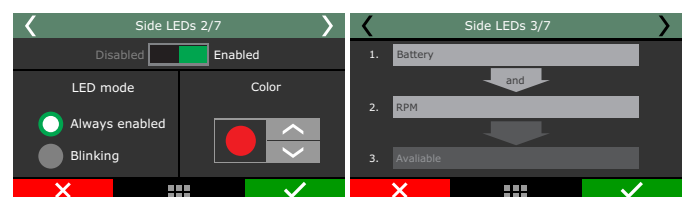
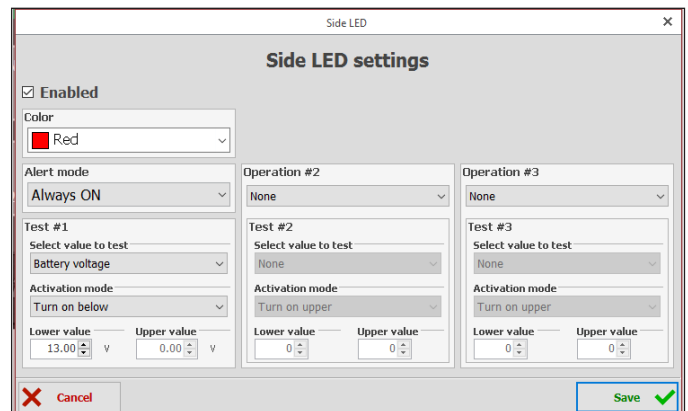

LCD backlight settings

Adjust LCD brightness side LED's and select between night and day modes.

LEDs Testing

This option verify if all LEDs are working properly. Selecting this function the LEDs must turn on with the same color and at the same time, in case any LED do not turn on you must get in contact with FuelTech maintenance sector.

23.4 Virtual LEDs configuration (FT450 and FT550)

Virtual LEDs are configured the same way as in the FT600, through the ECU or the software.

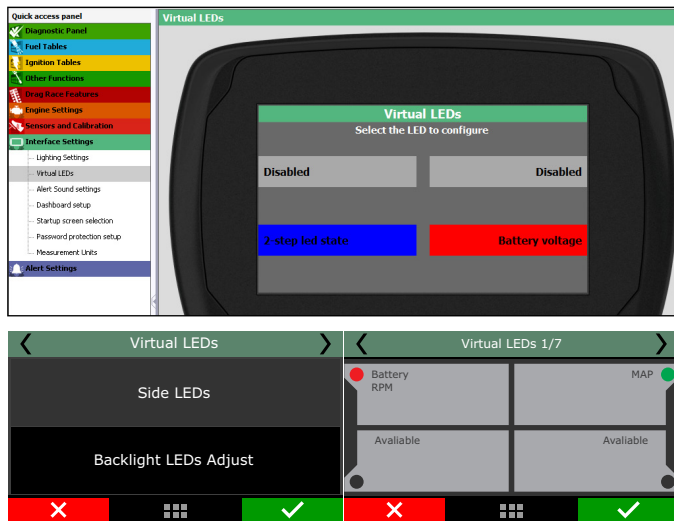

23.5 Alert sound settings

This parameter allows for setting the volume of sounds generated by touching the display. When the mute option is selected, the ECU is silent when the screen is touched.

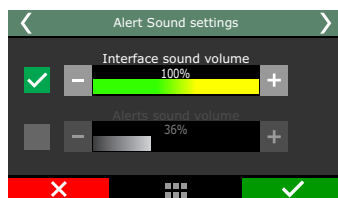

23.6 Dashboard setup

There are 96 configurable positions on the dashboard, with minimal size of 1x1. It's possible to select sizes as 1x2, 2x1, 2x2, 3x2 and 3x1, and full screen (only for Dials).

First, select the position where you want the information to be, then the reading that will be displayed and the reading size.

Dashboard setup is very simple, first select the number of dashboards you want (1 to 4), after that set the space will be used, and then, choose the information you want and select right to define the gauge size.

The option "Goto screen 1 on 2-Step" was developed for using with the dial function.

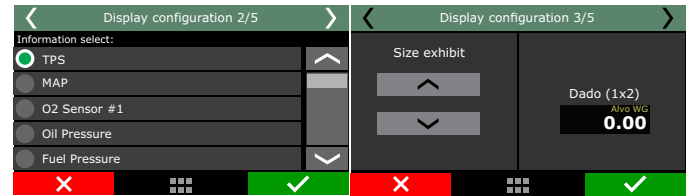
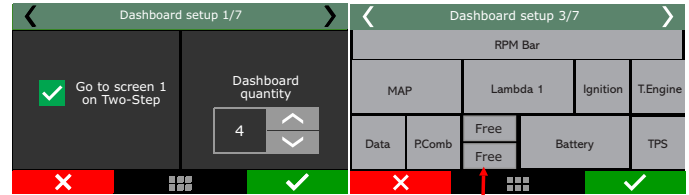

NOTE
After version 3.10 of FTManager is possible to set 4 different dashboards directly in the software clicking over the free gauges and editing the informations.

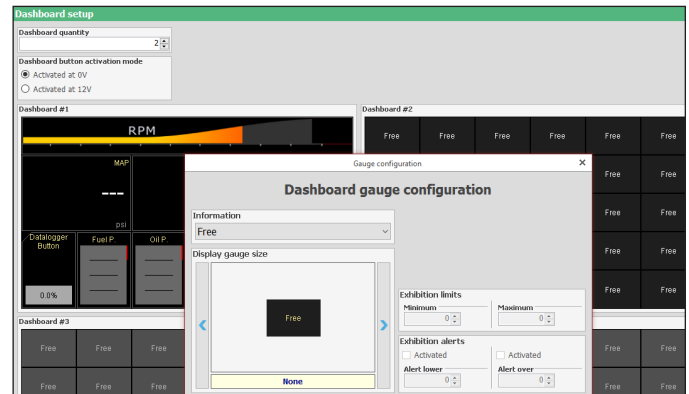

Clicking in the upper corners of the touchscreen the other configured dashboards will appear, as illustrated below, or it is also possible to set a white input as a button/switch key to change the dashboards.

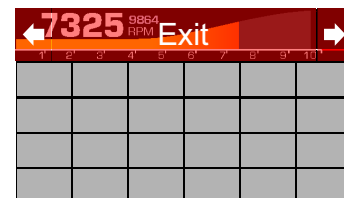

Exhibition limits and alerts

On some sensors, maximum and minimum values may be set up to activate alerts on the dashboard. In this case, the sensor changes it's color to indicate something is wrong. The sensors readings with these options are: MAP, air temperature, engine temperature, battery voltage, fuel pressure, oil pressure, TPS, dwell, ignition timing, primary injection time, secondary injection time, O2 sensor 1, O2 sensor 2 and delta TPS



RPM bar

When clicking the RPM bar parameter, it is possible to setup the RPM where the red zone starts.

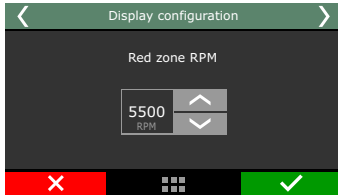

Dials - Bracket

This parameter will define your dial as well as your opponent's dial to allow the ECU to calculate the crosstalk timer when the opponent is dialed slower than you. This data can be viewed and changed via the instrument panel or on FT Manager.

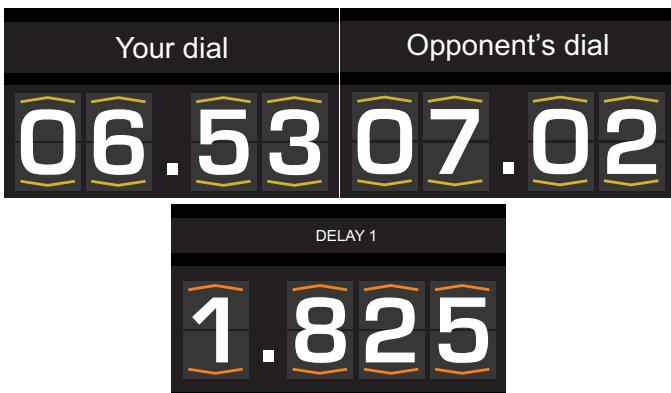

23.7 Startup screen selection

Select the screen shown right after the ECU is turned on. In case the option "Open the main menu after startup" is selected and the ECU is set up with a user password, the ECU will ask for the user password.

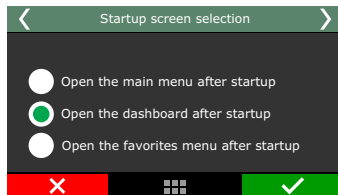

23.8 Splash Screen

This feature allows you to customize any image for the splash/start up screen. These settings can only be accessed through the FTManager software through the "Tools / Splash Screen " menu

- 1 - Buttons for writing to the ECU and importing an image.
- 2 - Preview screen.
- 3 - Options for positioning, alignment and sizing of the FuelTech's watermark (cannot be disabled).
- 4 - Options for zoom and alignment of image on the ECU's screen..

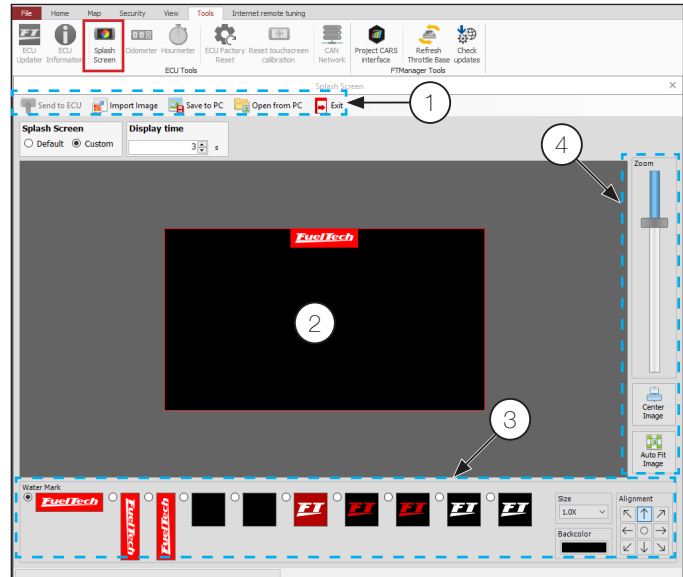

Through the touchscreen it is possible to select if the splash screen will be the default or a custom one.

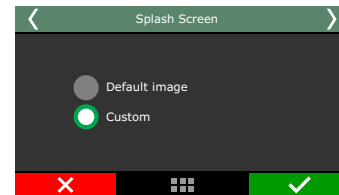

23.9 Password Protection setup

It is possible to set 2 different kinds of password:

ECU Password

Activating the ECU password allows three types of blocking protection:

- **FTManager:** choose this option to activate an FTManager access password, but keep all touchscreen menus accessible. Do this to avoid that a password being activated without your consent.
- **Menus:** This option protects all the ECU menus, only giving access to information displayed on the on board computer and engine status.
- **Engine Start:** Engine start blocking. All menus will be available for viewing and editing, but the ECU system will be blocked until the password is inserted.

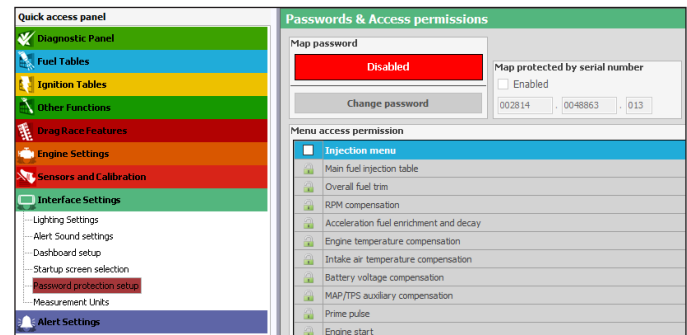

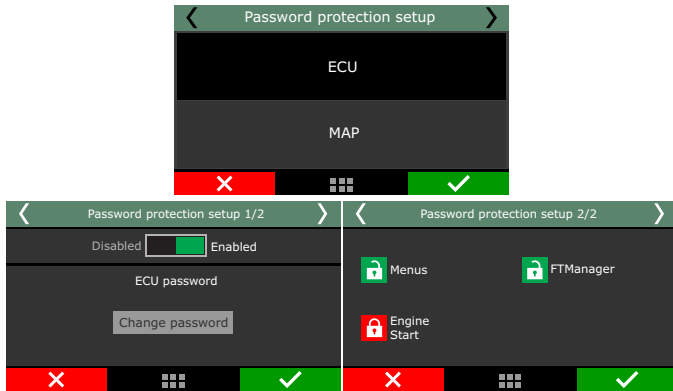

Map Password

This password blocks all the map menus of the fuel and ignition table adjustments, engine settings, aux function and file manager. Alert settings, shift alert, display and initial screen are left unprotected. When this password is enabled, it's not possible to change any ignition or fuel maps. The FTManager software access is also blocked by the Map password.



WARNING
Passwords come disabled by default, when you enable a password you will be blocking access to people using the ECU, even yourself. When you choose a password, be sure you will remember it, as for safety reasons this password will only be removed through the total reset of the ECU (all maps and data are erased).

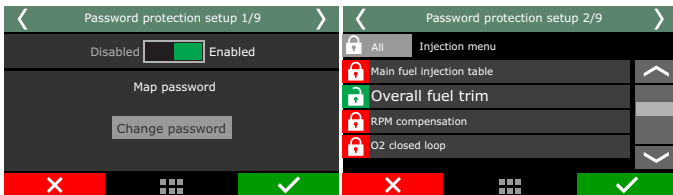

Maintenance Password

This password only used to block editing Odometer and Hourmeter.

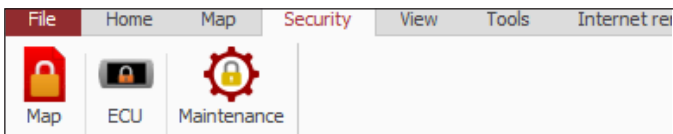

23.10 Clear peaks

At the Dashboard, values read by the sensors connected to the module are displayed in real time. On the bottom of each box on the display, the minimum (on the left) and maximum (on the right) values read by the sensor are shown.

It is possible to clear this data by accessing the option "Clear Peaks", under the "Interface Settings" menu.



23.11 Measurement units

In this menu it is possible to change the measurement unit for some parameters as pressure, temperature, speed and O2 readings.

Pressure Units: bar, PSI or kPa

Temperature units: °C or °F

O2 sensor units: Lambda, AFR Gasoline or AFR Methanol

Speed units: km/h or mph

Fuel flow unit: l/min, l/h, GPM, GPH, cc/min or lb/h

Volume: L or gal

Power: kW, CV or HP

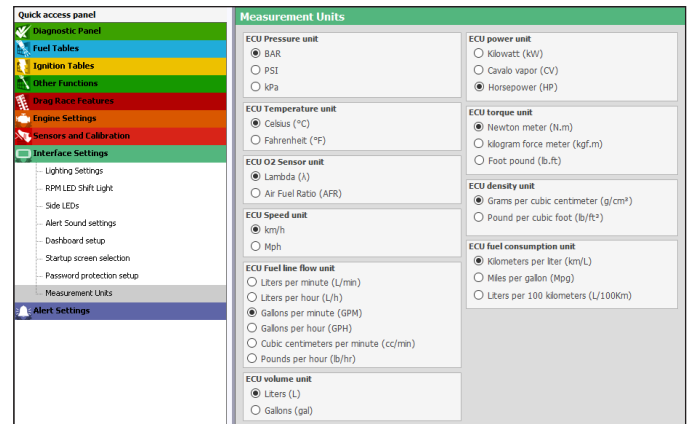

23.12 Demonstration mode

The demonstration mode can be enabled to show the main features of FuelTech FT and its working. You can set the waiting time to get in the demo mode. To exit, just touch the screen.

23.13 Touchscreen calibration

This function allows the touchscreen re calibration, use it whenever you notice the screen is unresponsive. Calibrate the screen with your finger or with a pen.

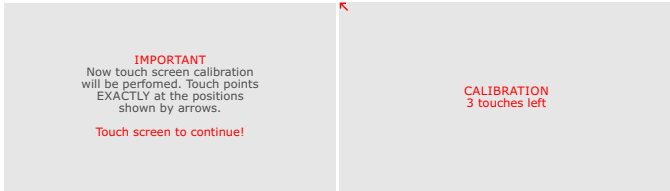

23.14 Serial number and software version

In this menu, it is possible to verify the software version and the equipment's serial number. Make sure you have these numbers in hand whenever the FuelTech Technical Support is contacted to facilitate and optimize the assistance.

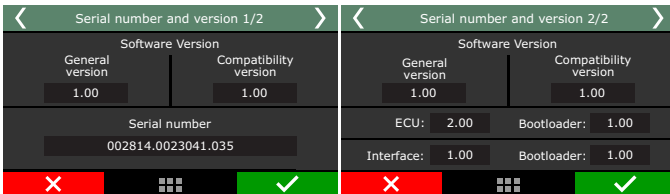

23.15 Odometer and Hourmeter

This function was specially designed for engines that require a mileage or timing control.

- Odometer:** Insert the mileage of the vehicle in the "total" field, this value can be edited only through the FTManager with the specific password, there is a "Partial" odometer that is possible to zero the value anytime.
- Hourmeter:** Follows the same principle of the Odometer, registering the engine hours in the "Total" field, having another field for "Partial" hours.



NOTE
These values are saved in the FuelTech memory, independently of the map that is active. The values can only be changed through the FTManager and through a previously configured password.

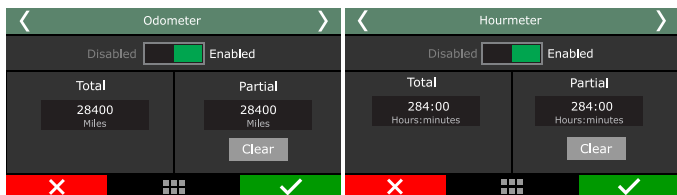
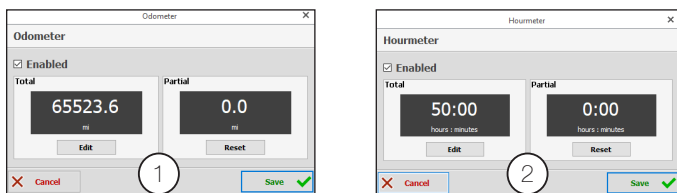
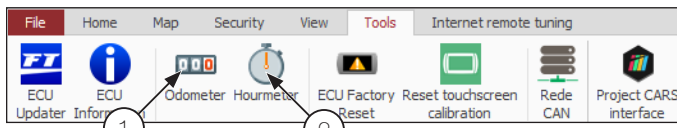

23.16 Practice Tree Game

The idea of this feature is to simulate the staging and launch of a drag racing car; allowing the driver to practice and achieve better reaction times.



NOTE
This feature requires 2-step to be set up and activated using an external button.

There are four different settings for how the drag tree is going to light up:

- Full: One light after the other
 - Pro: All three lights together
 - Rollout: The time it takes for the car to start moving after releasing the button.
- Drag tree simulator.
 - Staging simulator, the upper and bottom lines represent pre-staging and staging (only shows up if a staging button is configured).



NOTE
This feature is only available in the following ECUs: FT450, FT550 and FT600.

- Reaction time.

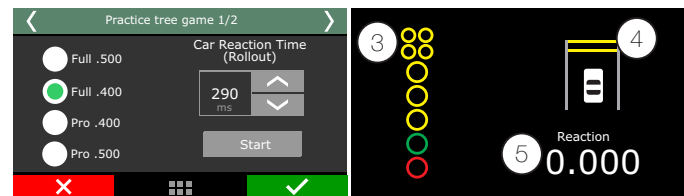

24. File manager

With the file manager it is possible to alternate between the 3 memory positions stored in the ECU. With this, you can have up to 3 totally different calibrations for different fuels or engines. Another option is to use the same ECU for up to 3 different engines with their own maps.

In the FTManager, the functions of File Manager are available in the tool bar.

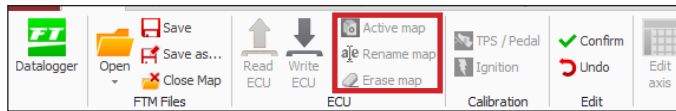
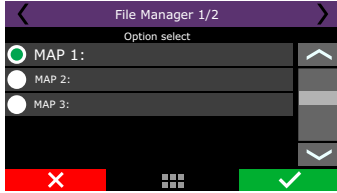

24.1 FuelTech base map generator

This function generates a base map that can be used to start engine tuning. It is very helpful because it gathers information from the "Engine setup" menu to create a base map to start engine.

Before using this function, make sure you have followed chapter 5 in this guide.

Further information about the assistant manager can be found in the Chapter 7.7 of this manual

24.2 Edit map file name

Edit the file map name after generating the FuelTech base map.

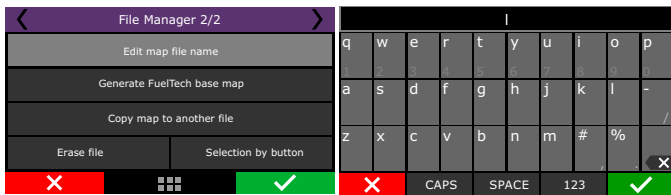

24.3 Copy map to another file

This option copies a map that is already setup, to an empty position or to overwrite a previous map. First, select the map that will be copied, click right, then select the option "Copy map to another file". On the next screen, map that will be copied is not shown, only the positions available to be overwritten.

In the example below, the Adjust 4 was copied to Adjust 1, which was empty:

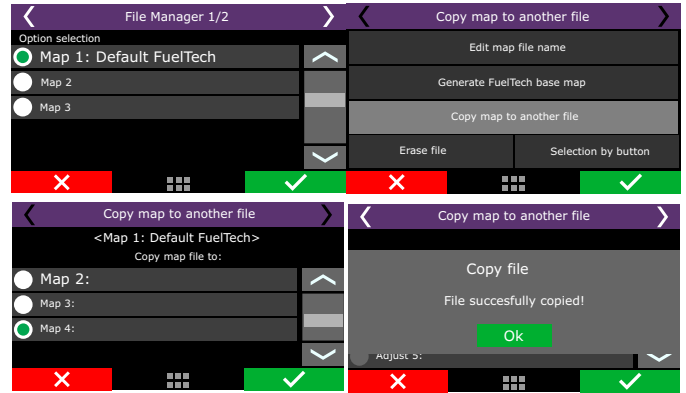

24.4 Erase file

Map files that will no longer be used can be easily erased with this option. To erase a file, simply enter on in by clicking right, then select option "Erase file". After the confirmation, every parameter that was previously changed will be erased to factory default.

24.5 Selection by button

In this option it's possible to quickly change the map through a button wired by an analogic input or a SwitchPanel button via CAN Network. You can set a single button to switch between maps or one button dedicated for each map.

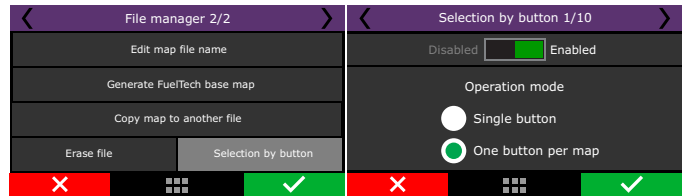

You must set which maps will be available to be switched and also whether it will be switched by analogic inputs or CAN Network.

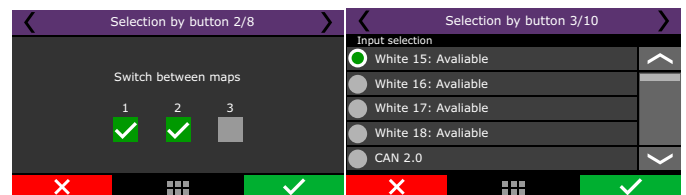

If switched by analogic input, it is necessary to set the activation voltage (0V or 12V). If switched by CAN Network, you just have to define the dedicated buttons in "Sensors and calibration/CAN communication/SwitchPanel" or directly from the FT screen.

25. Electrification

This section is dedicated to controlling electric and hybrid vehicles. The control and monitoring functions of the system for electrified vehicles will be explained.

Important notes

- FuelTech VCU will always send a torque request to the electrification system regardless of which Power Train is installed on the vehicle.
- The 12V battery is required to power the vehicle's original systems.
- The VCU post-switch will be done by a white input, that is, the VCU will always be "on" in standby mode and monitoring the 12V battery charge level and the Battery Pack charging.
- In standby condition, the VCU screen can be turned off to save the 12V battery. FuelTech VCU will draw 0.06A per hour in this standby mode.
- All communication between the VCU and the control modules of the electrification system is done through the CAN protocol. For more information, contact our technical support.

25.1 Glossary

BMS - Battery Management System: responsible for monitoring the battery pack cells. Informs the VCU in real time various information such as: cell voltage, current, temperatures, status and faults, etc. This equipment is only used when the battery pack is Li-Ion. For lead batteries the BMS is not required.

OBC - On-Board Charge: Battery pack charger. Connected together with the BMS to charge the battery pack when the vehicle is connected to a charging station.

DC/DC Converter: Responsible for charging the vehicle's 12V battery (the electric vehicle's alternator). This equipment keeps the 12V battery charged using the charge from the battery pack.

PDU - Power Distribution Unit: Power control unit for the battery pack. The system operates when the starter key is off or in an emergency, cutting the positive and negative of the battery pack.

Frequency Inverter: Responsible for effectively controlling the electric motor through torque and regeneration commands received from the VCU.

SOC - State of Charge: Informs the percentage of discharge and charge level of the battery pack.

Creeping: Function that works in conjunction with the brake pedal. When releasing the brake pedal, the vehicle will start to move without the need to press the accelerator.

Power Train: Pack of inverter and electric motor.

DCL - Discharge current limit: The discharge current limit of the battery pack.

CCL - Charge current limit: The battery pack charge current limit.

25.2 Power Train Settings

This function configures the type of Inverter/Motor and also the control mode including which outputs will be controlled for each system.

Inverter model

There are 5 configurable models available (WEG CWV300 and CWV500, Gtacke KTZ34, Kelly KAC8080 and SME A-X144) when selecting a model, different configuration options are enabled.

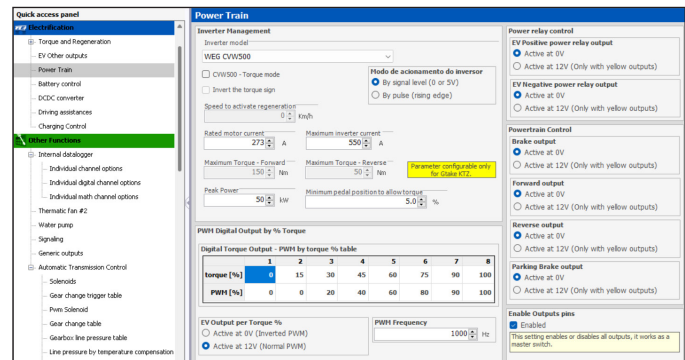

WEG CVW500 inverter: For this model, it is necessary to define the power reduction strategy; the speed to activate the regeneration mode, the minimum pedal position, the maximum and nominal current and the clockwise and counterclockwise torque.



WEG CVW300 Inverter: For this model, configure the minimum percentage of the pedal to allow torque, the maximum and nominal current of the motor and also the clockwise and counterclockwise torque.

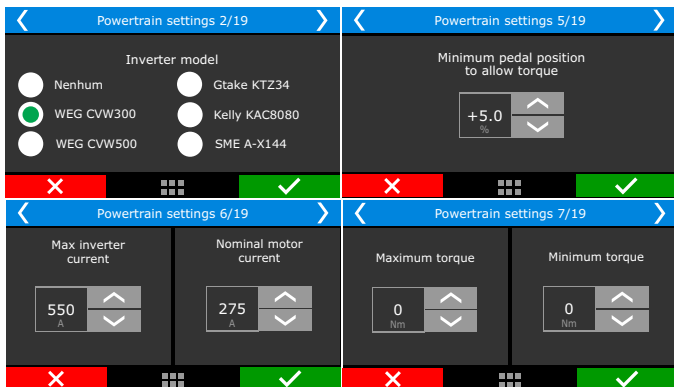

Gtake KTZ34 / Kelly KAC8080 / SME A-X144 Inverter: For this model, configure the minimum percentage of the pedal to allow torque, the maximum and nominal current of the motor and also the clockwise and counterclockwise torque.

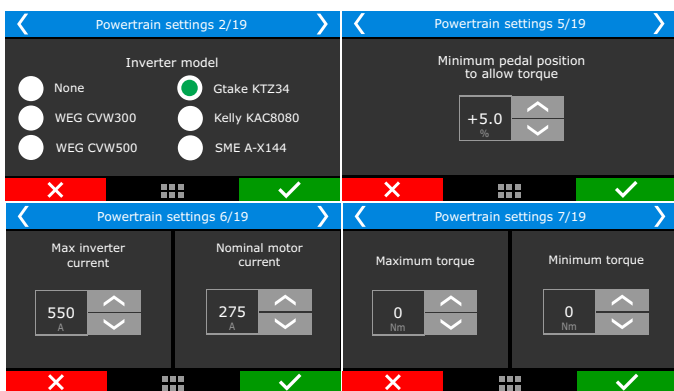

PWM digital output by % Torque

Some inverters have an analogue or PWM control input, it is possible to configure a PWM table by % of torque. In this case, it is necessary to define how the EV % of torque output is activated (0V inverted or 12V Normal), and adjust the frequency of this PWM.

Power relay control

Relay control activated by the VCU.

EV positive power relay output: Output to the vehicle's positive power relay.

EV Negative Power Relay output: Output for the vehicle's negative power relay.

Powertrain Control

Brake output: Output responsible for activating the regeneration function. It is necessary to configure the "Brake Light" function in the "Other Functions/Signalling" section, so that the regeneration control is activated.

Forward output: Output responsible for activating the relay connected to the inverter input that allows the vehicle to move forward.

Reverse output: Output responsible for activating the relay connected to the inverter input that allows the vehicle to move backwards.

Parking brake output: Output responsible for activating the relay connected to the vehicle's parking brake.

25.3 EV output configuration

This function is responsible for the operation mode of the car's EV system. The following outputs can be enabled, and whether they will be activated at 0V or 12V.

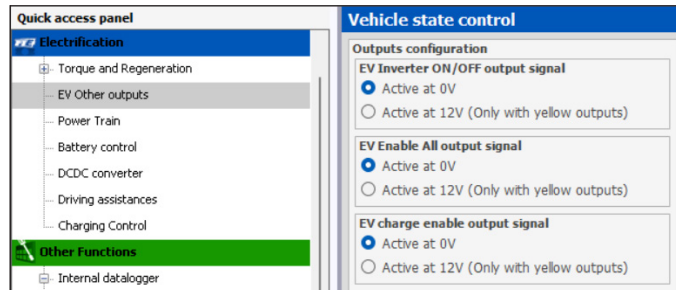

EV Inverter ON/OFF output signal: Output for initializing the vehicle's inverter.

EV Enable all output signal: Output for enabling the vehicle's inverter. Mainly used after pre-charging inverters.

EV charge enable output signal: Output for enabling the load that the inverter will release on the vehicle.

25.4 Torque and Regen

In this function it is possible to configure the torque and regeneration tables for different vehicle conditions. The percentages within each table will be multiplied between all tables to build the required values of torque and/or regeneration.

Tables available for torque % by:

Pedal Position, RPM, Speed, Battery Voltage, Cell Voltage, Battery SOC, Inverter Temperature, Motor Temperature, Battery Temperature.

Tables available for regeneration % by:

Brake Pressure, Pedal Position, Battery Voltage, Cell Voltage, Speed, Battery Temperature, Battery SOC, RPM, Motor Temperature, Inverter Temperature.

For example: In the pedal position table, the user informs the VCU that with 10% of TPS the torque request is 100% while in the torque by speed table it is informed that at 1km/h, the motor operates with a torque of 20%. When the user is pressing 100% of the acceleration pedal, but the vehicle is at 1km/h or less, only 20% of torque will be released to the engine, due to the multiplication of the tables. The same works for regeneration tables, if they are configured accordingly.

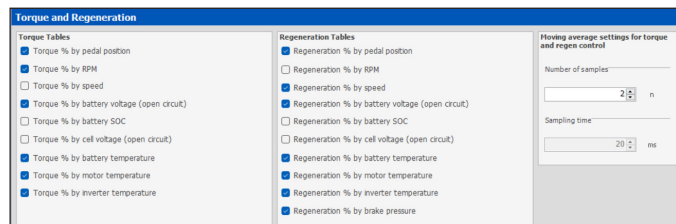

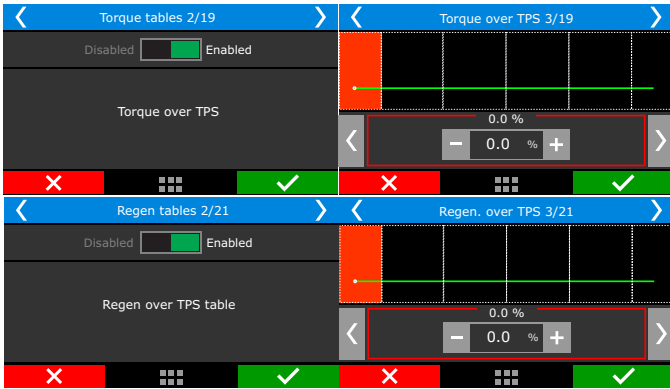

Moving average setting for torque and regen control

Number of samples: The number of samples to calculate the average torque and regen value.

Torque moving average period: Adjusts the time between each sample capture for the average calculation. The recommended value is 20ms.

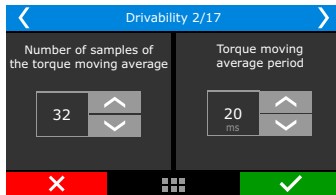

25.5 Battery

This function manages the charge of the battery pack. The parameters configured here will serve as the basis for controlling the battery pack charge.

There are four BMS (charge controllers) options to choose from:

Without BMS: used when the battery pack is built with conventional lead cell batteries. It is necessary to adjust the DCL and CCL parameters. It is recommended to use a current sensor in the battery pack and connect it to a white “HV Battery Current” input on the VCU.

ORION / LITHIUM and WEG: for these BMSs it is necessary to configure the minimum and maximum SOC to allow torque and regeneration, in addition to configuring the detraction limit and speed to turn off these controls.

Inverter pre-charge time: this is the time the inverter takes to perform the pre-charge, during this configured time the VCU will not send torque requests to the inverter.

Battery energy: in this field it is necessary to inform the energy in kWh of the battery pack. This value will be used to calculate the efficiency metrics.

Efficiency metrics

It is possible to activate information about autonomy and battery consumption as the vehicle travels. These values are updated every 100 meters driven by the vehicle.

Last trip: Calculation of how much power was used (W), and how much distance was travelled (km). This distance is counted after every 100 meters traveled until the moment it is turned off.

Last charge: Calculation of how much power was used (W), and how much distance was travelled (km). This distance is counted since the last time the vehicle was recharged.

Total: Metric accounting for the power used (W), and how much distance traveled (km). This distance is total until the metric is reset to zero.

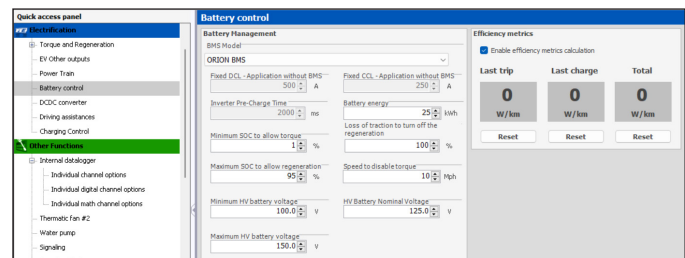
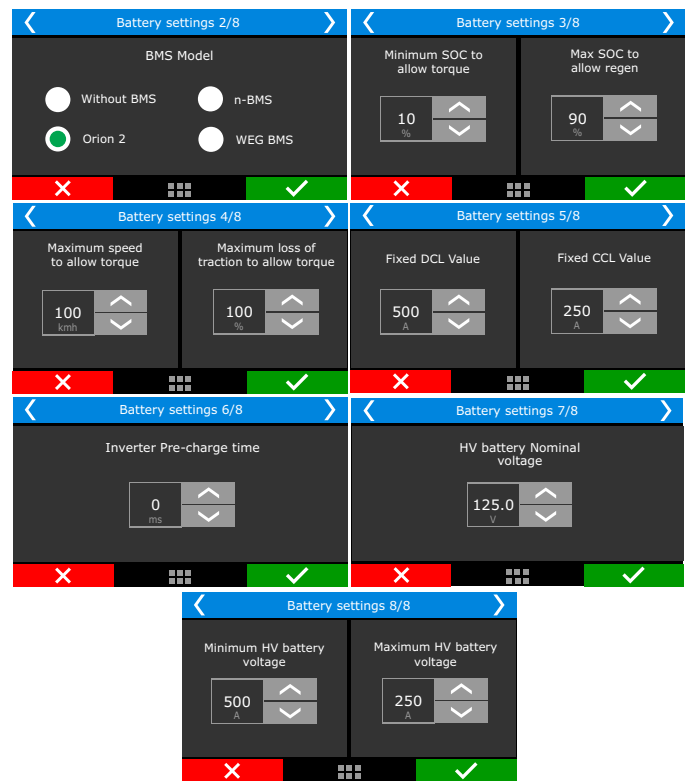

25.6 DCDC Converter

This function is responsible for communicating with the vehicle's DC/DC charger, and informs the essential parameters for operation

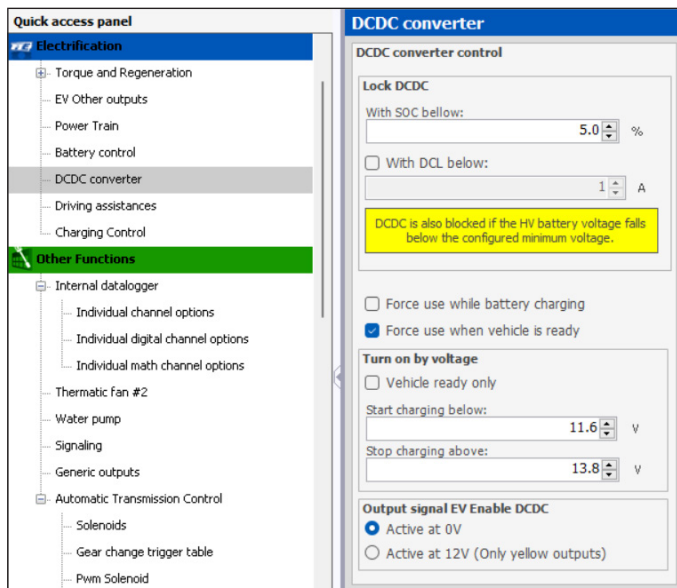

Allow DC/DC with SOC above: In this setting, create a charge limit so that the battery pack can start charging the vehicle's 12V battery.

Force use while battery charging & vehicle ready: Allows you to release the 12V battery charge while the vehicle is running or plugged into the charging socket.

Charge battery below and above: Create limits in Volts for 12V battery charge.

EV Output Signal Enabled DC/DC: configures the output signal for activating the relay for DC/DC operation.

25.7 Driveability

This function contains general vehicle driving settings such as: Creeping, reverse gear limiter, vehicle direction control and GearController.

Creeping

When activating this function, the vehicle will start to move as soon as the pressure on the brake pedal is being reduced by the driver. This function is very similar to a vehicle with an automatic transmission when the brake pedal is released.

Adjust the parameters so that the creeping function works as best serves the driver.

Creeping target by: defines whether the target will be based on vehicle speed or electric motor RPM.

Maximum torque at which the control will saturate: The percentage of torque at which the creeping function will deactivate.

Initial ramp of creeping torque: Creates a ramp from 0% to the value configured in "Maximum torque at which the control will saturate".

There are two ways to control time and pressure:

By time: When the brake is detected as inactive, the function will wait the configured time to reach the maximum torque value.

By brake pressure: When releasing pressure on the brake pedal, an interpolation will be made between the brake detection points and the maximum torque target. "Brake Servo" must be configured in the "Other functions" menu.

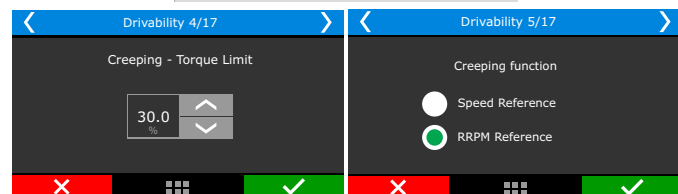
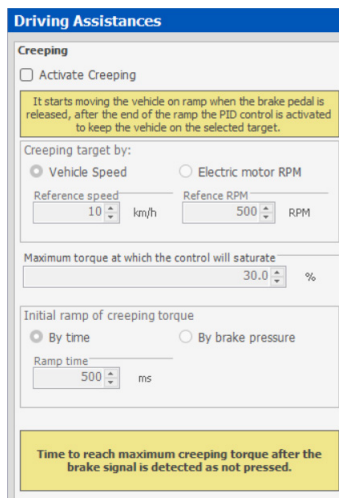

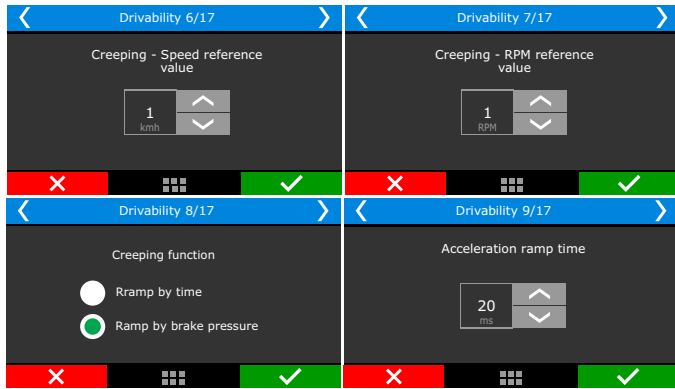

Reverse Limiter: Activates the reverse speed limit control. This control is very important as electric cars can reach the same speed in forward and reverse, it is mandatory to adjust these limits. There are the same configurable parameters as the creeping function, minus the ramp.

Forward / reverse reversal: For electric vehicles, direction reversal is performed using a button not only through the gearbox (when equipped), it is necessary to define the maximum speed at which the change of direction will be performed. It is possible to press the direction change button at any time, but it will only act when the speed is below the maximum configured speed.

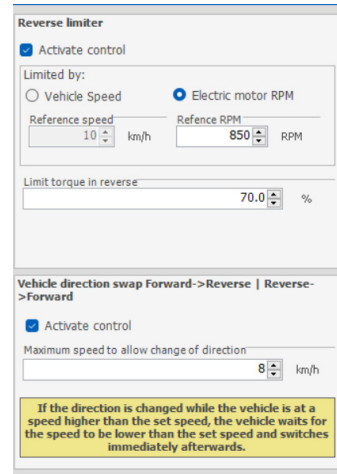

GearController EV: Torque control for each gear change controlled by a button, when pressed, cuts engine torque electrically, in order to change gears without using the clutch. (Only for vehicles equipped with a gearbox).

Advanced settings: These settings act directly on the function's PID, in 99% of cases it is not necessary to adjust these parameters. If you are going to change any of these values, contact our technical support to seek guidance on how to proceed.

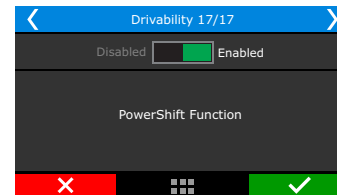
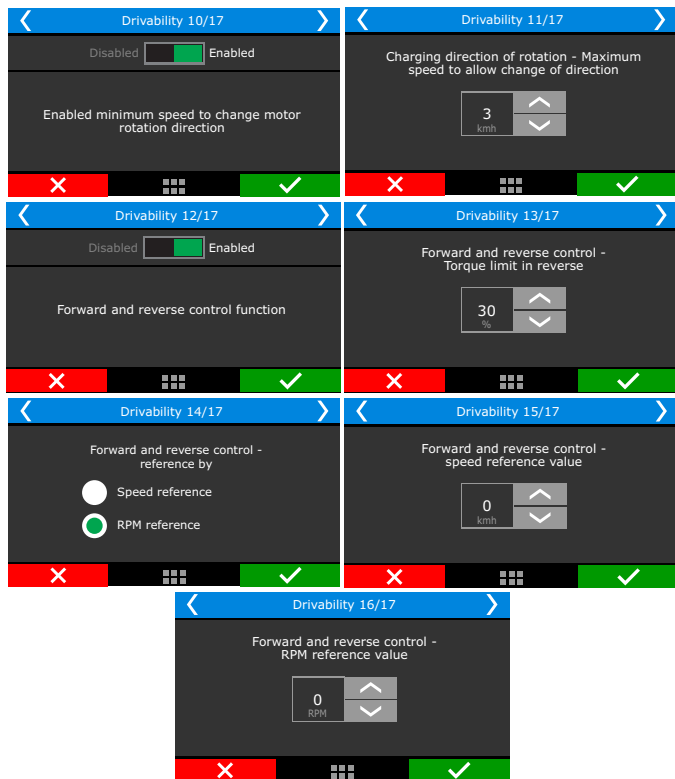

25.8 Charging Control

This function allows you to configure which On Board Charger will be used in the vehicle. Select the OBC Model and the VCU will be set with the parameters necessary for correct functioning of the charger.

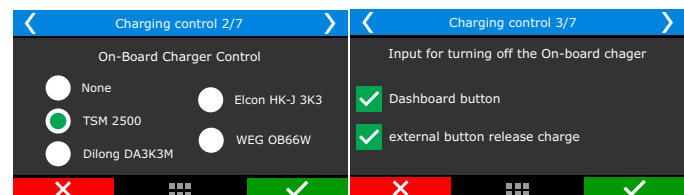
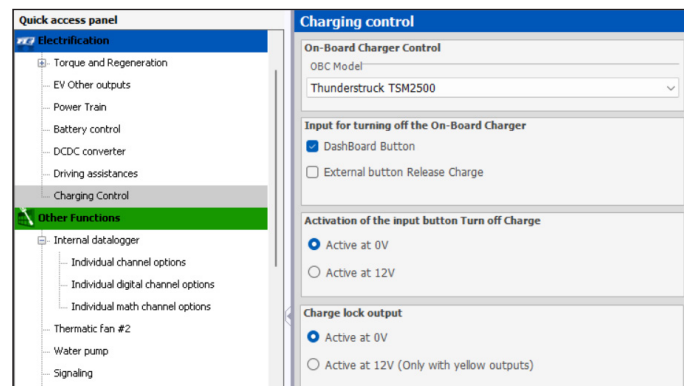

26. Rotary engines setup

FuelTech ECU will control the ignition timing using the reference of the 24 tooth wheel to calculate timing values based on the main timing table and corrections. All ignition timing programmed in the tables is referenced to the leading coil.

The trailing coil will be fired using the final calculated value from main timing table, including all corrections and timing controls, with an applied correction from the rotary timing split table. This means that if the ignition timing in the main table is 0° with no corrections and timing controls and the timing split is set as -10 ° in the rotary timing split table specific cell, the ECU will fire the leading coil at 0° and the trailing coil 10° after leading coil was fired.

If the rotary timing split values are different when the engine is operating with multiple cells, the ECU will interpolate the value between the cells and apply that value.



26.1 Crank angle sensor installation and alignment

The Crank Angle Sensor needs to be installed in the engine at 0° (top dead center position). To align it, follow this quick step by step

1. Use your ignition timing marks in the damper to align the eccentric to TDC. The ignition timing mark to be used is shown below.

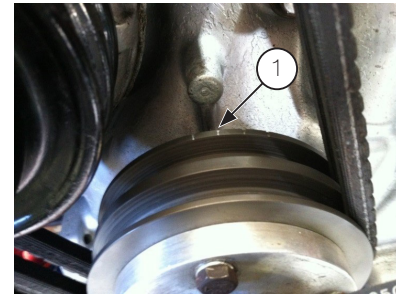

2. Align the Crank Angle Sensor to 0° using the mark in the shaft.

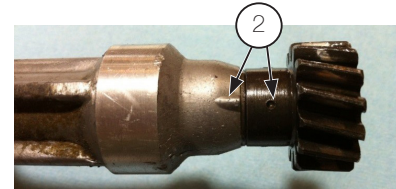

3. Install and tighten the Crank Angle Sensor in the engine. After the steps above are correctly followed, the Crank Angle Sensor should be aligned at TDC with the eccentric shaft.

26.2 Crank angle sensor wiring

The stock distributor will be read by FT as a Crank Angle Sensor and Camshaft Position Sensor. Here's how to connect the FT to your stock Mazda distributor:

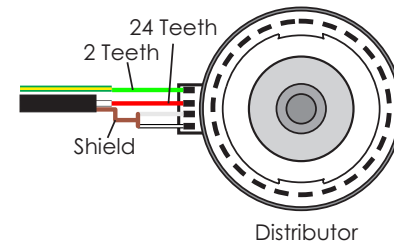

Function	Distributor wire	FuelTech wire	FuelTech pin
24 teeth signal (crank signal)	Red	Red from black shielded cable	1
24 teeth sensor negative	White	White from black shielded cable	2
2 teeth signal (home)	Green	Red from gray shielded cable	3
2 teeth sensor negative	White/Black	White from gray shielded cable	4

For engines using trigger wheel instead of distributor, here are the connections:

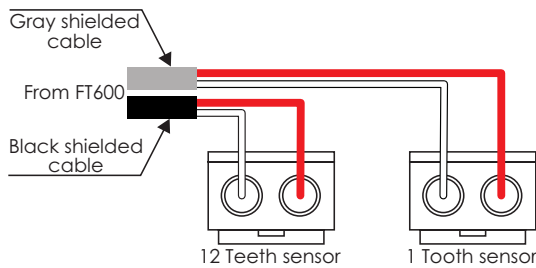

- A - White from black shielded cable (crank trigger white wire)
- B - Red from black shielded cable (crank trigger red wire)
- C - White from gray shielded cable (Cam sync white wire)
- D - Red from gray shielded cable (Cam sync red wire)

Function	FuelTech wire	FuelTech pin
12 teeth sensor (crank signal)	Red from black shielded cable	1
12 teeth sensor negative	White from black shielded cable	2
1 tooth sensor (home signal)	Red from gray shielded cable	3
1 tooth sensor negative	White from gray shielded cable	4

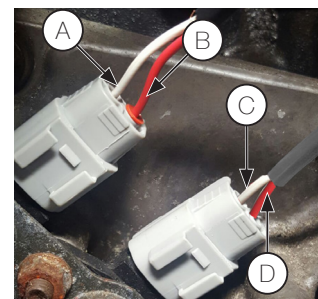

26.3 ECU setup

First, go to Fuel Injection Setup and enter the following:

- Max RPM: setup according to your engine;
- Injection mode: setup according to your engine;
- Idle by: TPS (fixed injection time on idle), MAP (injection time by MAP readings);
- Engine type: Rotary;
- Max boost pressure: setup according to your engine;
- Injectors banks: FT has two banks, setup how you want to use them (both as primary or A as primary and B as secondary);
- Acceleration fuel enrich: use by TPS, it's more accurate;

- Number of cylinders/rotors: setup according to your engine;
- Fuel injectors deadtime: if you don't have this info about your injectors, use 1,00ms;

Now, go to Ignition Setup and select:

- Ignition: Crank/Cam Ref. w/ Multi Coils;
- Crank Trigger Pattern: select option "12 (at crank) 24 (at cam)";
- First Tooth Alignment: 0 teeth or 5° BTDC;
- Crank Ref Sensor: VR differential;
- Crank Ref Edge: Falling edge;
- Cam sync position angle: 23° BTDC;
- Cam Sync Sensor: VR differential (FT600);
- Cam Sync Polarity: Falling edge;

Ignition output edge

Ignition system	ECU ignition output edge
Spark Pro	Falling dwell (Inductive / SparkPRO)
MSD DIS-2(1)	Rising duty (CDI)
MW Pro-14/R(2)	Falling dwell (Inductive / SparkPRO)
MW-Pro Drag 4/R(3)	Falling dwell (Inductive / SparkPRO)

Notes:

1. Use two (2) ignition units
2. Considering that MW PRO-14/R trigger edge need to be configured as Falling Dwell leaving pins 9 to 10 unconnected. See page 9 of MW Ignition manual for more details
3. There is no set up the trigger edge of Pro-Drag 4/R. Trigger edge is Falling Dwell by default.

After setting up Fuel Injection Setup and Ignition Setup menus, make sure you go through chapter 11.3 to generate a fuel and timing base map for your engine.

26.4 Ignition coils wiring

After setting everything up, the ignition outputs of the ECU are ready to be connected to your coils or ignition modules. FT ECU ignition outputs cannot be connected directly to dumb coils, only to smart coils (coils with integrated ignition module) or ignition modules.

For 2 rotor engines, the gray wires are connected as the table below shows:

ECU ignition output	Function	Recommended SparkPRO-4 channel
Gray wire #1	Leading rotor #1 – Coil L1	Channel 1
Gray wire #2	Leading rotor #2 – Coil L2	Channel 2
Gray wire #3	Trailing rotor #1 – Coil T1	Channel 3
Gray wire #4	Trailing rotor #2 – Coil T2	Channel 4

For 3 rotor engines, the gray wires are connected as the table below shows:

ECU ignition output	Function	Recommended SparkPRO-6 channel
Gray wire #1	Leading rotor #1 – Coil L1	Channel 1
Gray wire #2	Leading rotor #2 – Coil L2	Channel 2
Gray wire #3	Leading rotor #3 – Coil L3	Channel 3
Gray wire #4	Trailing rotor #1 – Coil T1	Channel 4
Gray wire #5	Trailing rotor #2 – Coil T2	Channel 5
Gray wire #6	Trailing rotor #3 – Coil T3	Channel 6

FT450

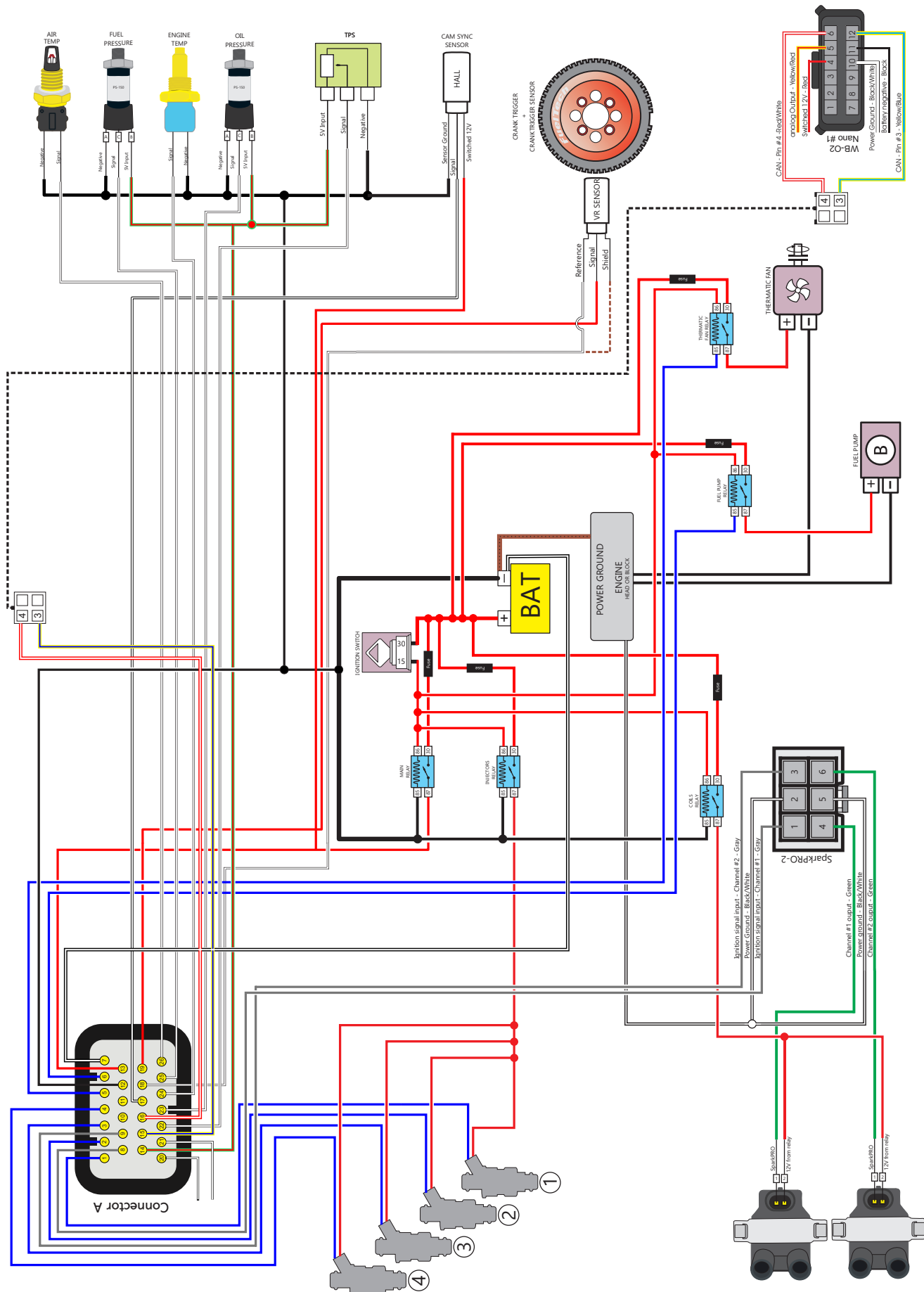

FT550

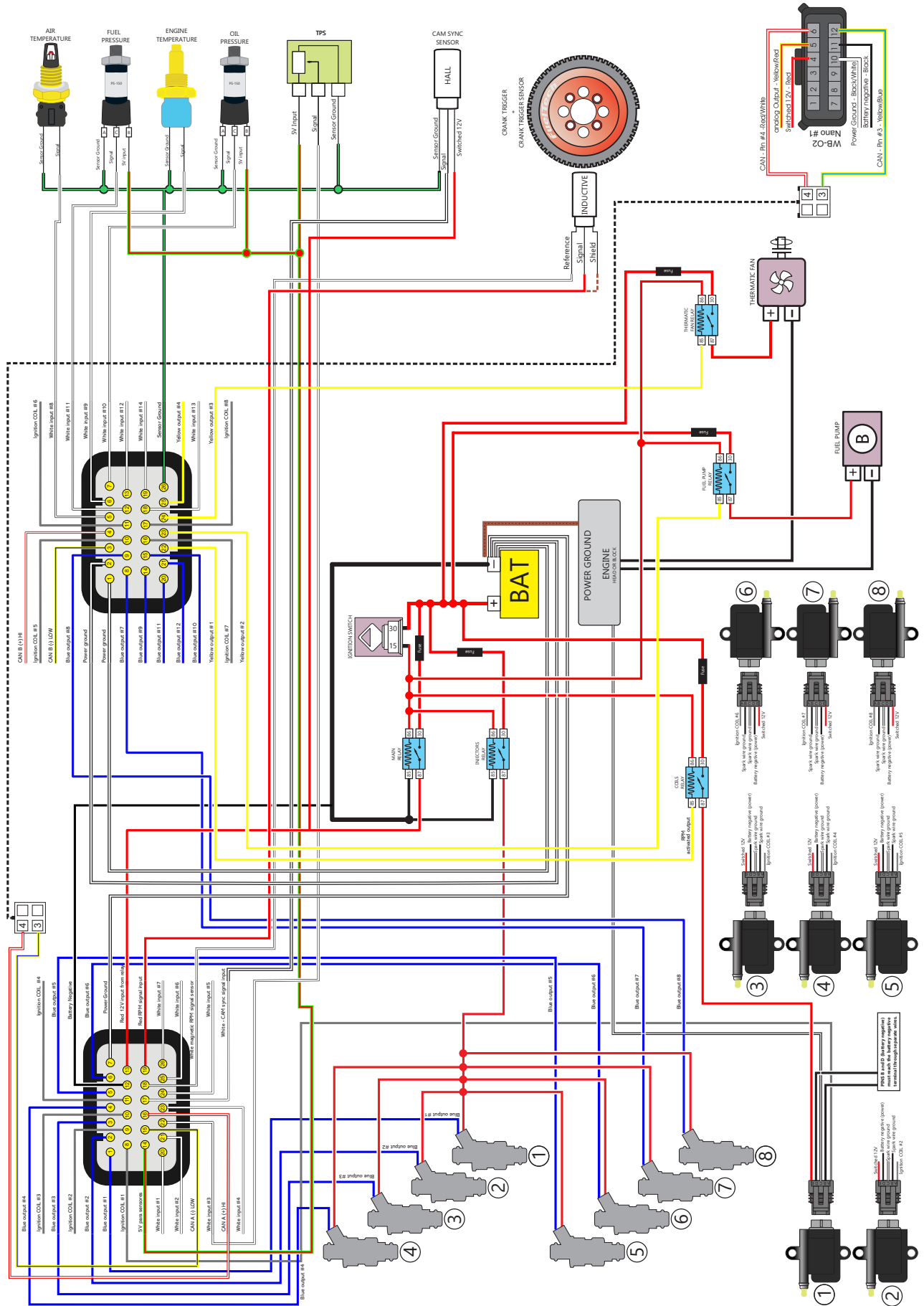

FT550

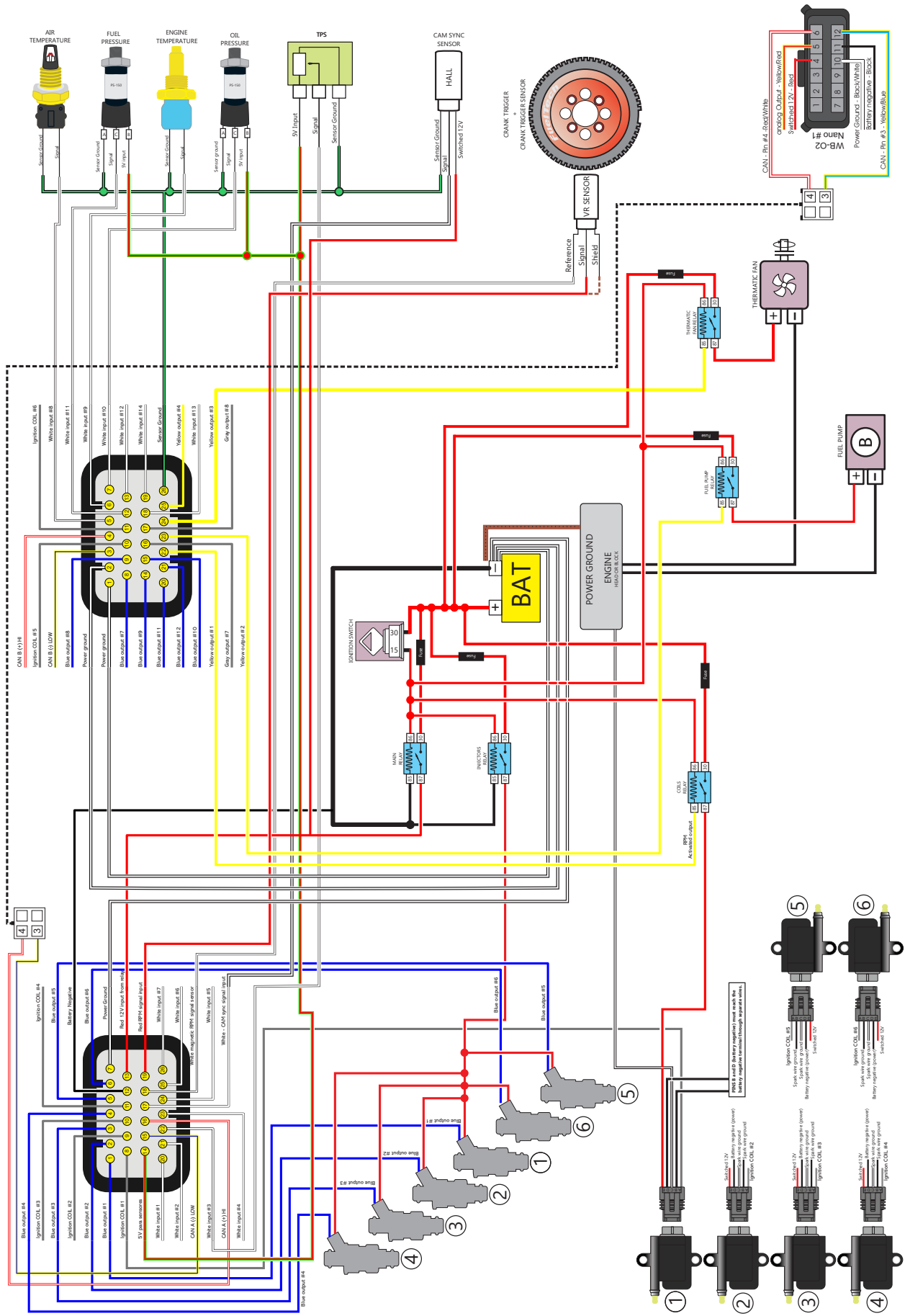

28. FT450 and FT550 mounting kit

- 1- 1/4" thread hex head screw
- 2- Mounting washer
- 3- Smart clip
- 4- Nut
- 5- Rubber mounts



NOTE

To use the internal accelerometer available in the FT550, the nuts and rubber mounts must be used to absorb vibration, otherwise the readings will be incorrect.

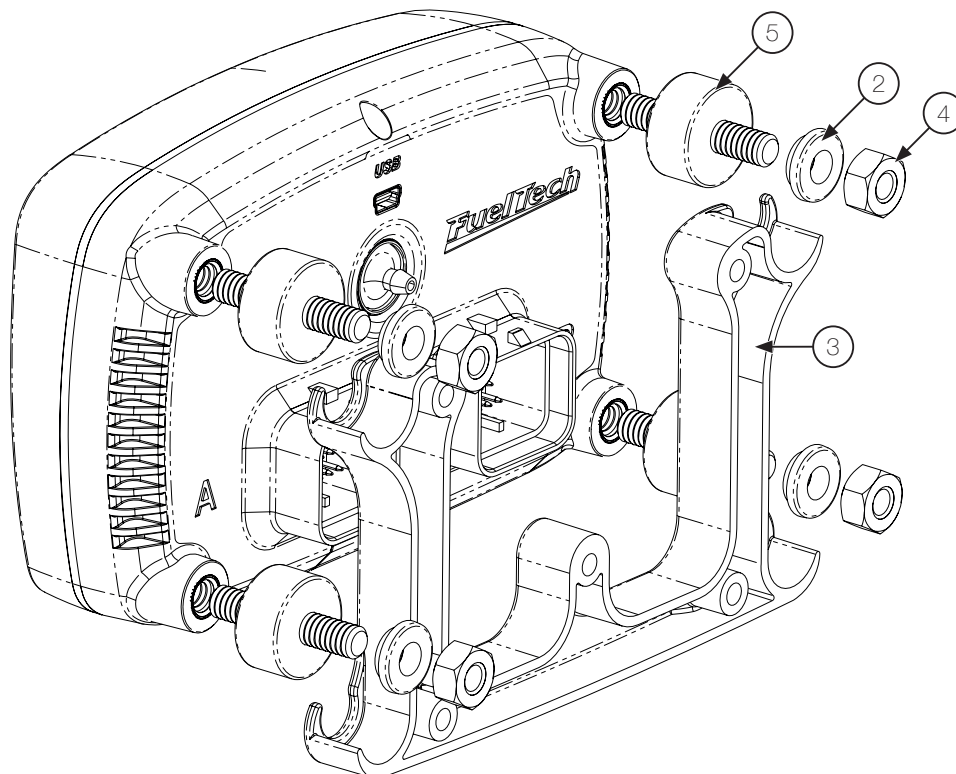
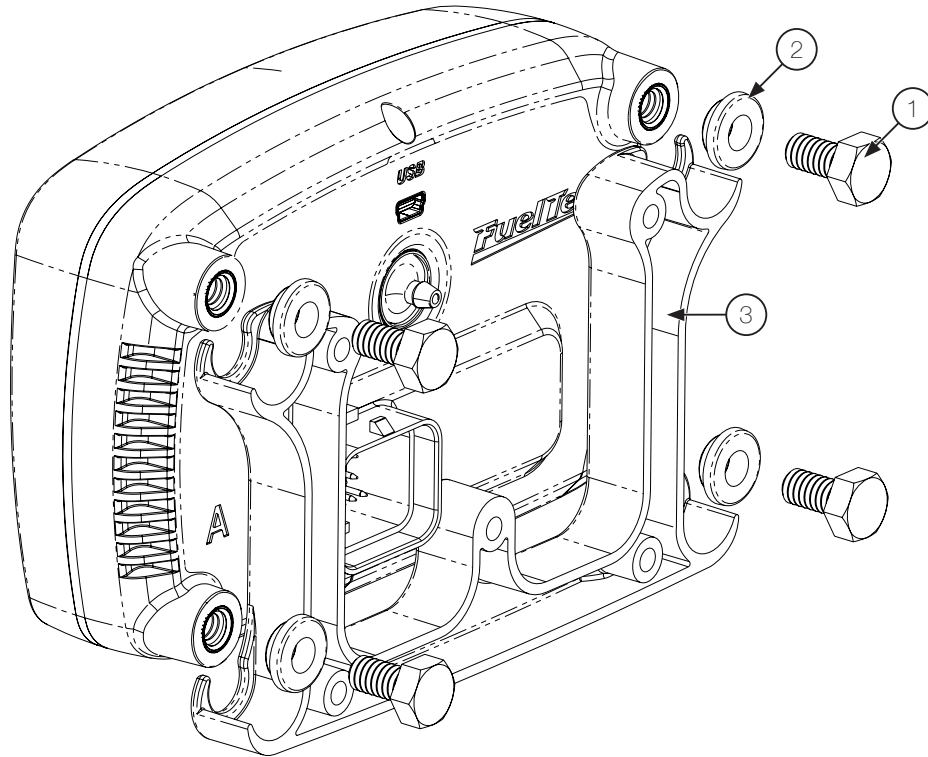

29. Bracket dimensions

FT450 / FT550

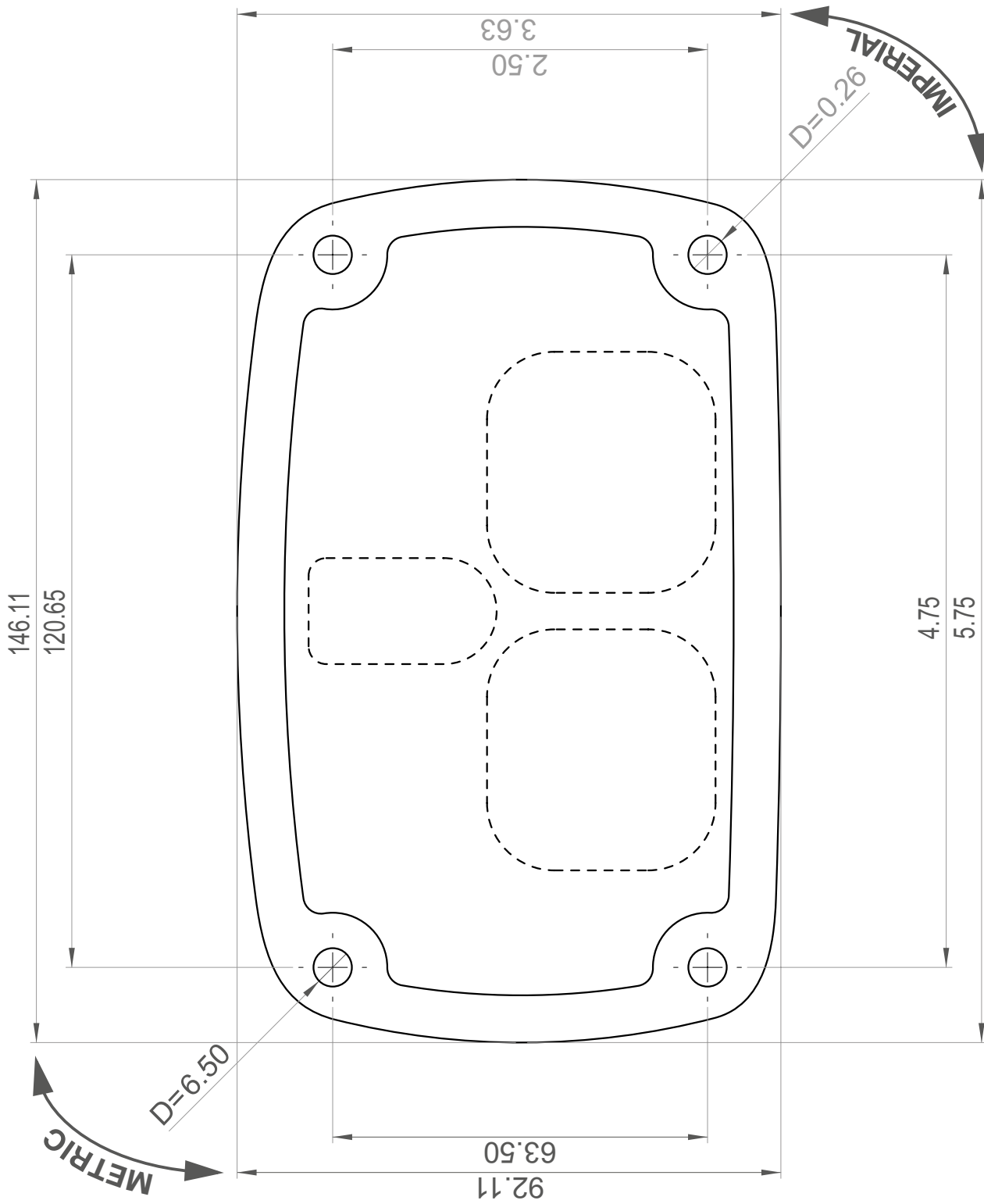

FT600

FuelTech ——— Fixing Template | Gabarito de Fixação | Plantilla de Fijación

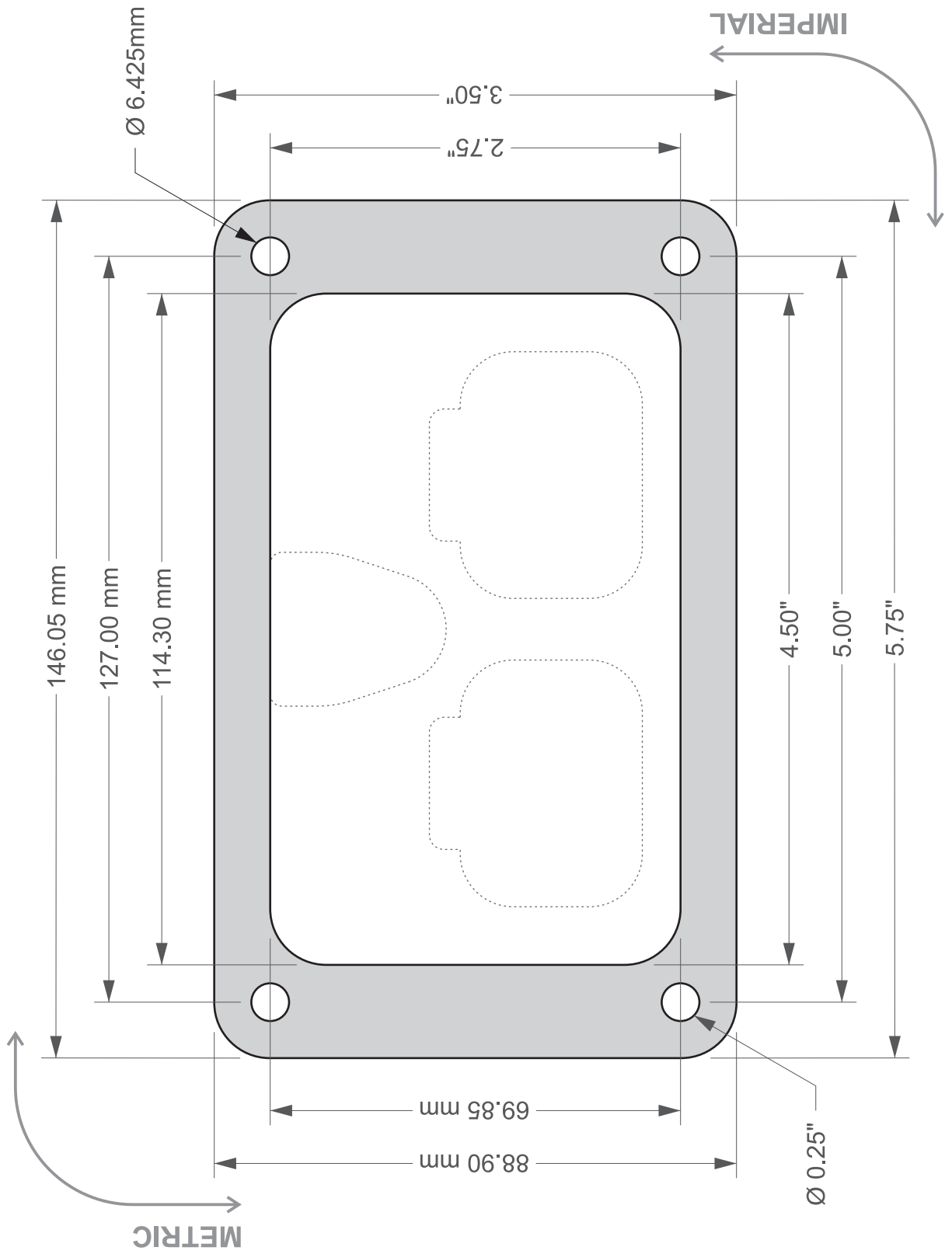

Smart Clip Dimensions FT450 / FT550

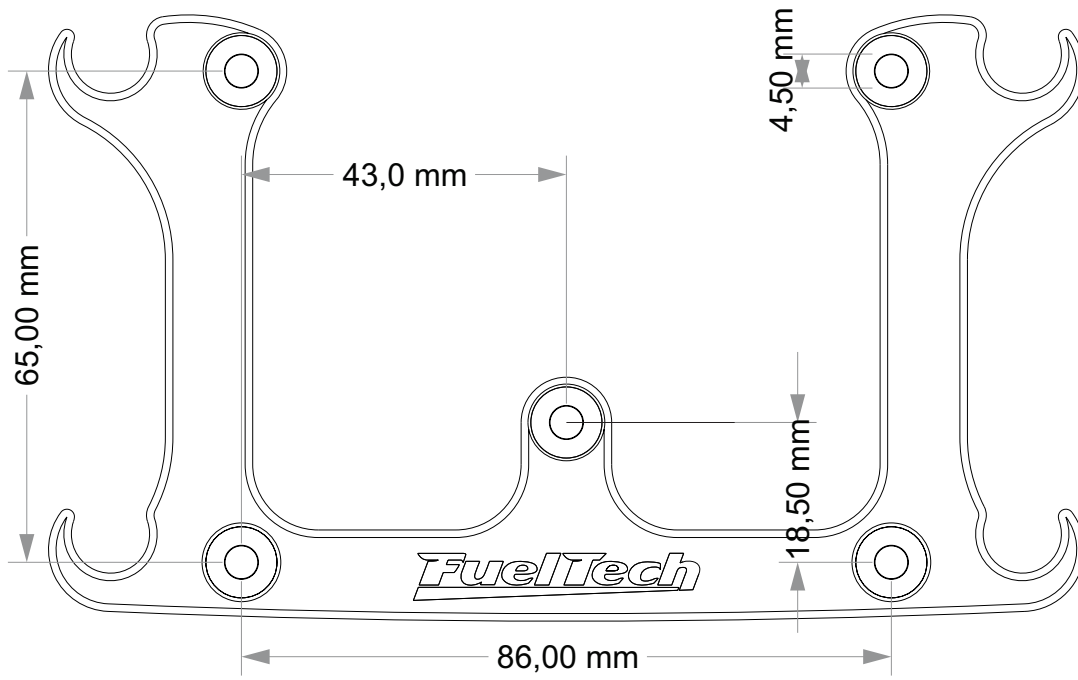

30. FTCAN 2.0 protocol

30.1 Physical layer

CAN 2.0B extended mode

Rate: 1Mbps

Features

In this document we will approach the implementation of a custom protocol (FTCAN) running on top of a CAN 2.0B physical layer. One main feature of the FTCAN protocol is to provide a means to segment a large stream of data into many smaller CAN packets. We will consider a CAN FRAME as indicated below:

CAN FRAME	
29 bits	0 to 8 bytes
IDENTIFICATION	DATA FIELD

30.2 IDENTIFICATION

The FTCAN will use the 29 bits of the IDENTIFICATION header to identify the device that originated the message. The 29 bits will be divided in order to provide information about: the unique product identifier, type of data and the type of message that is being sent. The bit division was planned in order to have multiple message priorities for the same type of product, and to have multiple priorities for the many different products inside the same CAN physical layer.

IDENTIFICATION (29 bits)		
Bits 28 to 14 (15 bits)	Bits 13 to 11 (3 bits)	Bits 10 to 0 (11 bits)
ProductID	DataFieldID	MessageID

ProductID

Identifies the product that has sent the message. The lower the ProductID the higher is the priority in the CAN bus. In the network two devices that are the same type of product (two O2 sensors for example) cannot have the same ProductID. In order to differentiate two products of the same type the ProductID bits are divided as show below.

ProductID (15 bits)	
Bit 14 to 5 (10 bits)	Bits 4 to 0 (5 bits)
ProductTypeID	Unique identifier

Each product that wants to send data to the CAN bus must have a unique identifier. Devices that will only receive data from the CAN bus doesn't need to have a unique ID.

The ProductIDs are divided in priority ranges:

- Critical priority: 0x0000 to 0x1FFF
- High priority: 0x2000 to 0x3FFF
- Medium priority: 0x4000 to 0x5FFF
- Low priority: 0x6000 to 0x7FFF

A list with all the possible ProductTypeID's is presented later in this document.

DataFieldID

Identifies the type of data structure that is being sent in the CAN FRAME -> DATA FIELD. There are 4 possible data layouts:

- 0x00: Standard CAN data field
- 0x01: Standard CAN data field coming from/going to a bus converter.
- 0x02: FTCAN 2.0 data field
- 0x03: FTCAN 2.0 data field coming from/going to a bus converter.

MessageID

Identifies the data in the DATA FIELD. Example: commands, configuration data, real time readings, etc. The lower the MessageID the higher is the priority. The MessageID's most significant bit is reserved in order to identify a response from a command:

MessageID (11 bits)	
Bit 10	Bits 9 to 0 (10 bits)
Response (value 1)	Message code

The priorities ranges are:

- Critical priority: 0x000 a 0x0FF
- High priority: 0x100 a 0x1FF
- Medium priority: 0x200 a 0x2FF
- Low priority: 0x300 a 0x3FF

A list with all the possible MessageIDs is presented later in this document.

30.3 DATA FIELD

The DATA FIELD can have up to 8 data layouts accordingly to the DataFieldID's value. All values in the DATA FIELD are transmitted as big-endian.

DataFieldID 0x00: Standard CAN

In this data layout all 8 bytes of the DATA FIELD are used as valid data (PAYLOAD). All data are transmitted in one shot since this mode doesn't implement data segmentation.

DATA FIELD (1 to 8 bytes)							
0	1	2	3	4	5	6	7
PAYLOAD							

DataFieldID 0x01: Standard CAN Bridge (bridge, gateway or converter)

In this data layout all 8 bytes of the DATA FIELD will be forwarded by the bus converter. The DataFieldID (0x01) is also used to identify packets that are originated outside the CAN bus. Bridge examples are: Standalone USB-CAN converter, FT500's USB-CAN bridge, etc.

DATA FIELD (1 to 8 bytes)							
0	1	2	3	4	5	6	7
PAYLOAD							

DataFieldID 0x02: FTCAN 2.0

This is the DataFieldID that all FuelTech's devices will use to communicated with each other in the CAN bus. The data segmentation feature is implemented in this type of data layout. As can be seen in the diagrams below the segmentation feature uses the first byte of the DATA FIELD to indicate which segment of the following bytes is. There can be 2 types of packets:

- Single packet (all data is transmitted in one CAN packet)
- Segmented packet (data is transmitted in multiples CAN packets)

Single packet

The first byte of the DATA FIELD will have the value of 0xFF. The following 7 bytes will have the message data (PAYLOAD).

DATA FIELD (1 to 8 bytes)							
0	1	2	3	4	5	6	7
0xFF	PAYLOAD						

Segmented packet

In the first byte of the DATA FIELD there will be values ranging from 0x00 to 0xFE. The first segment will have the 0x00 value and the following packets will contain 0x01, 0x02 and so on. In the first segment the 2 bytes following the 0x00 value contain the segmentation data.

DATA FIELD (8 bytes)							
0	1	2	3	4	5	6	7
0x00	SEGMENTATION DATA		PAYLOAD				

First segment

DATA FIELD (1 to 8 bytes)							
0	1	2	3	4	5	6	7
0x00	PAYLOAD						

Second segment

DATA FIELD (1 to 8 bytes)							
0	1	2	3	4	5	6	7
0x01	PAYLOAD						

Third segment (if present)

DATA FIELD (1 to 8 bytes)							
0	1	2	3	4	5	6	7
0x02	PAYLOAD						

Last segment (if present)

DATA FIELD (1 to 8 bytes)							
0	1	2	3	4	5	6	7
0xFE	PAYLOAD						



NOTE

The maximum PAYLOAD length will be: $5 + (0xFD * 7) = 1776$ bytes.

The segmentation data contains the following information:

SEGMENTATION DATA (2 bytes)																
Bytes	1								2							
Bits	15	14	13	12	11	10	9	8	7	6	5	4	3	2	1	0
	RFU	RFU	RFU	RFU	RFU	PAYLOAD total length (in bytes)										

RFU: Reserved for Future Use

DataFieldID 0x03: FTCAN 2.0 Bridge (bridge, gateway or converter)

This DataFieldID uses the same data layout from DataFieldID's 0x02 when the data is going to or coming from a BUS converter.

30.4 Attachments

ProductID's list

Since the 5 least significant bits of the ProductID are used for the unique value the FTCAN protocol can have up to 32 devices of the same product type at the same time. The unique value will range from 0x00 to 0x1F. The limit for different products types will be 1024.

Priority	ProductID			Product Type
	ProductTypeID	Range		
		Start	Finish	
Critical	-----	0x0FFF	0x0FFF	Device searching a ProductID (unique value undefined)
High	0x0140	0x2800	0x281F	Gear Controller
High	0x0141	0x2820	0x283F	Knock Meter
High	0x0142	0x2840	0x285F	Boost Controller 2
High	0x0150	0x2A00	0x2A1F	Reserved for Future Use
Medium	0x0240	0x4800	0x481F	WBO2 Nano
Medium	0x0241	0x4820	0x483F	WBO2 Slim
Medium	0x0242	0x4840	0x485F	Alcohol O2
Medium	0x0243	0x4860	0x4861	FTSPARK
Medium	0x0244	0x4880	0x4881	Switchpanel-8
Medium	0x0244	0x4882	0x4883	Switchpanel-4
Medium	0x0244	0x4884	0x4885	Switchpanel-5
Medium	0x0244	0x4886	0x4887	Switchpanel-8 mini
Medium	0x0245	0x48A0	0x48BF	Reserved for Future Use
Medium	0x0246	0x48C0	0x48DF	Reserved for Future Use
Medium	0x0280	0x5000	0x501F	FT500 ECU
Medium	0x0281	0x5020	0x503F	FT600 ECU
Medium	0x0282	0x5040	0x505F	First reserved range for future ECUs
Medium
Medium	0x02E4	0x5C80	0x5C9F	Last reserved range for future ECUs
Low	0x0340	0x6800	0x681F	Reserved for Future Use
Reserved	-----	0x0800	0x0800	FuelTech EGT-8 CAN (model A)
Reserved	-----	0x0880	0x0880	FuelTech EGT-8 CAN (model B)

Example: A FT500 device with the unique value of 3 will have the following ProductID:

$$(0x0280 \ll 5) + 3 = 0x5003$$

Where 0x0280 is the ProductTypeID for FT500 and 3 is the unique value. The "<<" is the C language command rotate bit left, 0x0280 << 5 is the same as multiply 0x0280 with 0x0020.

MessageID's list

- 0x0FF, 0x1FF, 0x2FF e 0x3FF – Real time reading broadcast
 - 0x0FF – Critical priority
 - 0x1FF – High priority
 - 0x2FF – Medium priority
 - 0x3FF – Low priority

Those are the MessageIDs that the FuelTech's device will use to transmit its real time readings. The rate for each broadcast will depend

on the type of data, critical data will be broadcasted more often. Examples of critical data: Ignition Cut, Two Step signal, emergency signals, etc. Examples of high priority data: RPM, ignition timing, actual injection flow, MAP, TPS, etc.

Values are always transmitted as signed 16 bits in big-endian byte order.

Statuses are transmitted as big-endian unsigned 16 bits.

Each real time data will be composed of 4 bytes:

REAL TIME DATA	
0-1	2-3
Data identifier (MeasureID)	Value or status (big endian)

If a device needs to broadcast more than one reading at the same time it can do so using a segmented packet:

Segmented packet PAYLOAD	
MEASURE 1	
0-1	2-3
MeasureID	Value/Stat

MEASURE 2	
4-5	6-7
MeasureID	Value/Stat

MEASURE 3	
8-9	10-11
MeasureID	Value/Stat



NOTE

The maximum number of measures that can be transmitted on segmented packages are: $1776/4 = 444$

Another possibility is to use a CAN standard data frame to transmit 2 measures at a time, all the devices in the CAN bus must be capable of receiving data using all the data layouts.

Segmented packet PAYLOAD			
MEASURE 1		MEASURE 2	
0-1	2-3	4-5	6-7
MeasureID	Value	MeasureID	Value

The MeasureIDs transmitted in each message are:

MessageID	Measure 1		Measure 2		Measure 3		Measure 4	
	MeasureID	Description	MeasureID	Description	MeasureID	Description	MeasureID	Description
0x600	0x0002	TPS	0x0004	MAP	0x0006	Air temp	0x0008	Engine temp
0x601	0x000A	Oil pressure	0x000C	Fuel pressure	0x000E	Water pressure	0x0022	Gear
0x602	0x004E 0x004F	Exhaust O2	0x0084	ECU RPM	0x0118	Oil temp	0x011A	PitLimit Switch

MeasureIDs

The least significant bit of the MeasureID is used to indicate if the following value is the actual value or the reading status. Considering that the MeasureID have 16 bits in total we will use 15 bits to identify the data that is being transmitted.

MeasureID	
Bits 15 to 1	Bit 0
Data identifier (DataID)	0: Data value 1: Data status

A list with the available MeasureIDs is presented further in this document.

- 0x600, 0x601, e 0x602 – Real time simple broadcast

Those are the MessageIDs that the FuelTech's device will use to transmit its real time readings using a fixed set of MeasureIDs. Each measure value is prefixed in a specific position in payload. The rate for each broadcast is 100Hz.

Values are always transmitted as signed 16 bits in big-endian byte order.

The data is transmitted **always** using a CAN standard data frame (DataFieldID 0x00) to transmit 4 measures at a time as shown in the following image:

Segmented packet PAYLOAD			
MEASURE 1	MEASURE 2	MEASURE 3	MEASURE 4
0-1	2-3	4-5	6-7
Value	Value	Value	Value

MeasureID	DataID	Description	Unity	Multiplier	Broadcast source (rate*)
0x0000	0x0000	Unknown	-	-	-
0x0002	0x0001	TPS	%	0.1	PowerFT ECU 100Hz
0x0004	0x0002	MAP	Bar	0.001	
0x0006	0x0003	Air temperature	°C	0.1	PowerFT ECU 10Hz
0x0008	0x0004	Engine temperature			
0x000A	0x0005	Oil pressure	Bar	0.001	PowerFT ECU 100Hz
0x000C	0x0006	Fuel pressure			
0x000E	0x0007	Water pressure			
0x0010	0x0008	ECU Launch Mode (2-Step, 3-Step, Burnout, Burnout + Spool)	-	Note 1	PowerFT ECU 100Hz
0x0012	0x0009	ECU Battery voltage	Volts	0.01	PowerFT ECU 100Hz
0x0014	0x000A	Traction speed	Km/h	1	PowerFT ECU 100Hz Gear Controller 100Hz
0x0016	0x000B	Drag speed			
0x0018	0x000C	Left front wheel speed	Km/h	1	PowerFT ECU 100Hz
0x001A	0x000D	Right front wheel speed			
0x001C	0x000E	Left rear wheel speed			
0x001E	0x000F	Right rear wheel speed			
0x0020	0x0010	Driveshaft RPM	RPM	1	PowerFT ECU 100Hz
0x0022	0x0011	Gear	-	Note 2	PowerFT ECU 100Hz Gear Controller 100Hz
0x0024	0x0012	Disabled O2	λ	0.001	WBO2 Nano 100Hz WBO2 Slim 100Hz Alcohol O2 100Hz
0x0026 0x0027	0x0013	Cylinder 1 O2	λ	0.001	PowerFT ECU 100Hz WBO2 Nano 100Hz WBO2 Slim 100Hz Alcohol O2 100Hz
0x0028 0x0029	0x0014	Cylinder 2 O2			
0x002A 0x002B	0x0015	Cylinder 3 O2			
0x002C 0x002D	0x0016	Cylinder 4 O2			
0x002E 0x002F	0x0017	Cylinder 5 O2			
0x0030 0x0031	0x0018	Cylinder 6 O2			
0x0032 0x0033	0x0019	Cylinder 7 O2			
0x0034 0x0035	0x001A	Cylinder 8 O2			
0x0036 0x0037	0x001B	Cylinder 9 O2			
0x0038 0x0039	0x001C	Cylinder 10 O2			
0x003A 0x003B	0x001D	Cylinder 11 O2			
0x003C 0x003D	0x001E	Cylinder 12 O2			
0x003E 0x003F	0x001F	Cylinder 13 O2			
0x0040 0x0041	0x0020	Cylinder 14 O2			
0x0042 0x0043	0x0021	Cylinder 15 O2			
0x0044 0x0045	0x0022	Cylinder 16 O2			

MeasureID	DataID	Description	Unity	Multiplier	Broadcast source (rate*)
0x0046 0x0047	0x0023	Cylinder 17 O2	λ	0.001	PowerFT ECU 100Hz WBO2 Nano 100Hz WBO2 Slim 100Hz Alcohol O2 100Hz
0x0048 0x0049	0x0024	Cylinder 18 O2			
0x004A 0x004B	0x0025	Left bank O2			
0x004C 0x004D	0x0026	Right bank O2			
0x004E 0x004F	0x0027	Exhaust O2			
0x0050	0x0028	Disabled EGT	°C	0.1	---
0x0052	0x0029	Cylinder 1 EGT	°C	0.1	PowerFT ECU 100Hz
0x0054	0x002A	Cylinder 2 EGT			
0x0056	0x002B	Cylinder 3 EGT			
0x0058	0x002C	Cylinder 4 EGT			
0x005A	0x002D	Cylinder 5 EGT			
0x005C	0x002E	Cylinder 6 EGT			
0x005E	0x002F	Cylinder 7 EGT			
0x0060	0x0030	Cylinder 8 EGT			
0x0062	0x0031	Cylinder 9 EGT			
0x0064	0x0032	Cylinder 10 EGT			
0x0066	0x0033	Cylinder 11 EGT			
0x0068	0x0034	Cylinder 12 EGT			
0x006A	0x0035	Cylinder 13 EGT			
0x006C	0x0036	Cylinder 14 EGT			
0x006E	0x0037	Cylinder 15 EGT			
0x0070	0x0038	Cylinder 16 EGT			
0x0072	0x0039	Cylinder 17 EGT			
0x0074	0x003A	Cylinder 18 EGT			
0x0076	0x003B	Left bank EGT			
0x0078	0x003C	Right bank EGT			
0x007A	0x003D	Exhaust EGT			
0x007C	0x003E	ECU O2 Sensor Unit	-	Note 3	PowerFT ECU 0.5Hz
0x007E	0x003F	ECU Speed Sensor Unit	-	Note 4	
0x0080	0x0040	ECU Pressure Sensor Unit	-	Note 5	
0x0082	0x0041	ECU Temperature Sensor Unit	-	Note 6	
0x0084	0x0042	ECU RPM	RPM	1	PowerFT ECU 1KHz
0x0086	0x0043	ECU Injection Bank A Time	ms	0.01	PowerFT ECU 100Hz
0x0088	0x0044	ECU Injection Bank B Time			
0x008A	0x0045	ECU Injection Bank A Duty Cycle	%	0.1	
0x008C	0x0046	ECU Injection Bank B Duty Cycle			
0x008E	0x0047	ECU Ignition Advance/Retard	°	0.1	PowerFT ECU 1KHz
0x0090	0x0048	2-Step Signal	-	Note 7	PowerFT ECU 1KHz Gear Controller 1KHz
0x0092	0x0049	3-Step Signal	-	Note 7	PowerFT ECU 100Hz
0x0094	0x004A	Burnout Signal			
0x0096	0x004B	ECU Cut	%	1	PowerFT ECU 100Hz
0x0098	0x004C	ECU Air Conditioning	-	Note 7	PowerFT ECU 100Hz
0x009A	0x004D	ECU Electro Fan			
0x009C	0x004E	GEAR Cut	%	1	Gear Controller 500Hz
0x009E	0x004F	GEAR Retard	°	0.1	

MeasureID	DataID	Description	Unity	Multiplier	Broadcast source (rate*)
0x00A0	0x0050	GEAR Sensor Voltage	Volts	0.001	Gear Controller 100Hz
0x00A2	0x0051	ECU Average O2	λ	0.001	PowerFT ECU 100Hz
0x00A4	0x0052	External Ignition output 1 discharge time	uS	1	FTSPARK 50Hz
0x00A6	0x0053	External Ignition output 2 discharge time			
0x00A8	0x0054	External Ignition output 3 discharge time			
0x00AA	0x0055	External Ignition output 4 discharge time			
0x00AC	0x0056	External Ignition output 5 discharge time			
0x00AE	0x0057	External Ignition output 6 discharge time			
0x00B0	0x0058	External Ignition output 7 discharge time			
0x00B2	0x0059	External Ignition output 8 discharge time			
0x00B4	0x005A	External Ignition output 9 discharge time			
0x00B6	0x005B	External Ignition output 10 discharge time			
0x00B8	0x005C	External Ignition output 11 discharge time			
0x00BA	0x005D	External Ignition output 12 discharge time			
0x00BC	0x005E	External Ignition output 13 discharge time			
0x00BE	0x005F	External Ignition output 14 discharge time			
0x00C0	0x0060	External Ignition output 15 discharge time			
0x00C2	0x0061	External Ignition output 16 discharge time			
0x00C4	0x0062	External Ignition Power Supply	mJ	1	
0x00C6	0x0063	External Ignition Power Supply Drop			
0x00C8	0x0064	External Ignition Power Level	°C	0.1	
0x00CA	0x0065	External Ignition Temperature			
0x00CC	0x0066	External Ignition Capacitor 1 charge	V	0.1	FTSPARK 50Hz
0x00CE	0x0067	External Ignition Capacitor 2 charge			
0x00D0	0x0068	External Ignition Capacitor 3 charge			
0x00D2	0x0069	External Ignition Capacitor 4 charge			
0x00D4	0x006A	External Ignition Capacitor 1 charge time	uS	1	
0x00D6	0x006B	External Ignition Capacitor 2 charge time			
0x00D8	0x006C	External Ignition Capacitor 3 charge time			
0x00DA	0x006D	External Ignition Capacitor 4 charge time			
0x00DC	0x006E	External Ignition Error code	-	Note 8	FTSPARK 25Hz
0x00DE	0x006F	External Ignition no load outputs	-	Note 9	
0x00E0	0x0070	External Ignition partial discharge outputs	-		
0x00E2	0x0071	External Ignition damaged outputs	-	Note 9	FTSPARK 25Hz
0x00E4	0x0072	External Ignition disabled outputs	-	Note 9	
0x00E6	0x0073	External Ignition operation status	-	Note 10	
0x00E8	0x0074	Power level config for external ignition	mJ	1	PowerFT ECU 10Hz
0x00EA	0x0075	Air conditioning button state	-	Note 7	Internal use only
0x00EC	0x0076	Two step button state			
0x00EE	0x0077	Three step button state			
0x00F0	0x0078	Transbreak button state	-	Note 7	Internal use only
0x00F2	0x0079	Burnout button state			
0x00F4	0x007A	ProNitrous button state			
0x00F6	0x007B	Progressive Nitrous #1 button state			
0x00F8	0x007C	Datalogger button state			
0x00FA	0x007D	Day/Night button state			
0x00FC	0x007E	Dashboard button state			
0x00FE	0x007F	Engine start button state			
0x0100	0x0080	Generic PWM output increase button state			
0x0102	0x0081	Gear upshift button state			

MeasureID	DataID	Description	Unity	Multiplier	Broadcast source (rate*)
0x0104	0x0082	Boost controller increase button state	-	Note 7	Internal use only
0x0106	0x0083	Gear reset button state			
0x0108	0x0084	Adjust change button			
0x010A	0x0085	Adjust 1 button			
0x010C	0x0086	Adjust 2 button			
0x010E	0x0087	Adjust 3 button			
0x0110	0x0088	Adjust 4 button			
0x0112	0x0089	Adjust 5 button	°C	0.1	Internal use only
0x0114	0x008A	Transmission temperature			
0x0116	0x008B	Intercooler temperature			
0x0118	0x008C	Oil temperature	-	Note 7	Internal use only
0x011A	0x008D	PitLimit Switch/Button			
0x011C	0x008E	Active Traction Control: enable switch			
0x011E	0x008F	Active Traction Control: table 1 button			
0x0120	0x0090	Active Traction Control: table 2 button			
0x0122	0x0091	Active Traction Control: table 3 button			
0x0124	0x0092	Active Traction Control: table 4 button			
0x0126	0x0093	Active Traction Control: table 5 button			
0x0128	0x0094	Active Traction Control: table 6 button			
0x012A	0x0095	Active Traction Control: next table button			
0x012C	0x0096	Active Traction Control: previous table button	°C	0.1	Internal use only
0x012E	0x0097	Tire temperature: Front Left			
0x0130	0x0098	Tire temperature: Front Right			
0x0132	0x0099	Tire temperature: Rear Left			
0x0134	0x009A	Tire temperature: Rear Right			
0x0136	0x009B	Track temperature	-	Note 7	Internal use only
0x0138	0x009C	Generic Input: button 1			
0x013A	0x009D	Generic Input: button 2			
0x013C	0x009E	Generic Input: button 3			
0x013E	0x009F	Generic Input: button 4			
0x0140	0x00A0	Generic Input: button 5			
0x0142	0x00A1	Generic Input: button 6			
0x0144	0x00A2	Generic Input: button 7			
0x0146	0x00A3	Generic Input: button 8	V	0.001	FTSPARK 25Hz
0x0224	0x0112	Left turn signal			
0x0226	0x0113	Right turn signal			
0x0228	0x0114	Low beam			
0x022A	0x0115	High beam	°C	0.1	FTSPARK 10Hz
0x022C	0x0116	External Ignition Switch voltage			
0x022E	0x0117	External Ignition CPU supply voltage	S	0.1	FTSPARK 10Hz
0x0230	0x0118	External Ignition CPU temperature			
0x0232	0x0119	External Ignition operation time	-	Note 7	Internal use only
0x0234	0x011A	MFI external switch			
0x0236	0x011B	Progressive Nitrous #2 button state			
0x0238	0x011C	Gear Reverse button			
0x023A	0x011D	Gear Drive button			
0x023C	0x011E	Blip signal	%	0.1	PowerFT ECU 10Hz
0x023E	0x011F	Bank A Injector 1 Duty cycle			
0x0240	0x0120	Bank A Injector 2 Duty cycle			
0x0242	0x0121	Bank A Injector 3 Duty cycle			

MeasureID	DataID	Description	Unity	Multiplier	Broadcast source (rate*)
0x0244	0x0122	Bank A Injector 4 Duty cycle	%	0.1	PowerFT ECU 10Hz
0x0246	0x0123	Bank A Injector 5 Duty cycle			
0x0248	0x0124	Bank A Injector 6 Duty cycle			
0x024A	0x0125	Bank A Injector 7 Duty cycle			
0x024C	0x0126	Bank A Injector 8 Duty cycle			
0x024E	0x0127	Bank A Injector 9 Duty cycle			
0x0250	0x0128	Bank A Injector 10 Duty cycle			
0x0252	0x0129	Bank A Injector 11 Duty cycle			
0x0254	0x012A	Bank A Injector 12 Duty cycle			
0x0256	0x012B	Bank B Injector 1 Duty cycle			
0x0258	0x012C	Bank B Injector 2 Duty cycle			
0x025A	0x012D	Bank B Injector 3 Duty cycle			
0x025C	0x012E	Bank B Injector 4 Duty cycle			
0x025E	0x012F	Bank B Injector 5 Duty cycle			
0x0260	0x0130	Bank B Injector 6 Duty cycle			
0x0262	0x0131	Bank B Injector 7 Duty cycle			
0x0264	0x0132	Bank B Injector 8 Duty cycle			
0x0268	0x0133	Bank B Injector 9 Duty cycle			
0x026A	0x0134	Bank B Injector 10 Duty cycle			
0x026C	0x0135	Bank B Injector 11 Duty cycle			
0x026E	0x0136	Bank B Injector 12 Duty cycle			
0x0270	0x0137	Gear downshift button state	-	Note 7	Internal use only
0x0274	0x0138	Battery temperature	°C	0.1	PowerFT ECU 10Hz
0x0276	0x0139	Available			

Only one of the possible sources is allowed to broadcast a specific DataID on the network. If one or more sources are broadcasting the same DataID a network conflict state is raised.

***The broadcast transmission rate may vary when the ECU is under high RPM.**

Note 1

- Value 0: None (running)
- Value 1: Burnout
- Value 2: Burnout Spool (Burnout and 2-Step)
- Value 3: 3-Step
- Value 4: 2-Step

Note 2

- Value -1: Reverse
- Value 0: Neutral
- Value 1: First gear
- Value 2: Second gear
- Value 3: Third gear
- Value 4: Fourth gear
- Value 5: Fifth gear
- Value 6: Sixth gear

Note 3

- Value 0: Undefined
- Value 1: Lambda
- Value 2: AFR ethanol
- Value 3: AFR methanol
- Value 4: AFR gasoline

Value 0xFF: Undefined

Note 4

- Value 0: Km/h
- Value 1: Mph

Note 5

- Value 0: bar
- Value 1: PSI
- Value 2: KPa

Note 6

- Value 0: °C
- Value 1: °F

Note 7

- Value 0: Off
- Value 1: On

Note 8

- **Bit 0:** Unknown pulse width received by the FT Ignition Bus.
- **Bit 1:** Incorrect ignition order in semi-sequential operation.
- **Bit 2:** Over voltage in the

high voltage bus. (external ignition disabled until next power cycle).

- **Bit 3:** Under voltage in the output drivers power supply. (external ignition disabled while condition exists).
- **Bit 4:** Charge circuit unable to charge capacitors.
- **Bit 5:** Power supply under voltage.
- **Bit 6:** 12V switch under voltage.

Note 9

- Bit 0: Output 1
- Bit 1: Output 2
- Bit 2: Output 3
- Bit 3: Output 4
- Bit 4: Output 5
- Bit 5: Output 6
- Bit 6: Output 7
- Bit 7: Output 8
- Bit 8: Output 9
- Bit 9: Output 10
- Bit 10: Output 11
- Bit 11: Output 12
- Bit 12: Output 13
- Bit 13: Output 14

- Bit 14: Output 15
- Bit 15: Output 16

Note 10

- Bit 0: Internal use
- Bit 1: Internal use
- Bit 2: High power mode enabled

Note 11

Incremental counter of errors in the respective cylinder

Simplified packets

In addition to the standard packets the FTCAN 2.0 can also be used in conjunction with simplified broadcast packets. This simplified broadcast packets have a fixed and defined data structure and are only broadcasted by the ECUs. The following table shows the simplified packets:

ID (FT500)	ID (FT600/550/450)	Bytes							
		1	2	3	4	5	6	7	8
0x14000600	0x14080600	TPS		MAP		Air temp		Engine Temp	
0x14000601	0x14080601	Oil Pressure		Fuel Pressure		Water Pressure		Gear	
0x14000602	0x14080602	Exhaust O2		RPM		Oil Temp		Pit Limit	
0x14000603	0x14080603	Wheel Speed FR		Wheel Speed FL		Wheel Speed RR		Wheel Speed RL	
0x14000604	0x14080604	Traction Ctrl - Slip		Traction Ctrl - Retard		Traction Ctrl - Cut		Heading	
0x14000605	0x14080605	Shock sensor FR		Shock sensor FL		Shock sensor RR		Shock sensor RL	
0x14000606	0x14080606	G-force (accel)		G-force (lateral)		Yaw-rate (frontal)		Yaw-rate (lateral)	
0x14000607	0x14080607	Lambda Correction		Fuel Flow Total					

30.5 Connector Pinout

PowerFT ECUs

Frontal view of the connector on the back of the ECU

CAN A

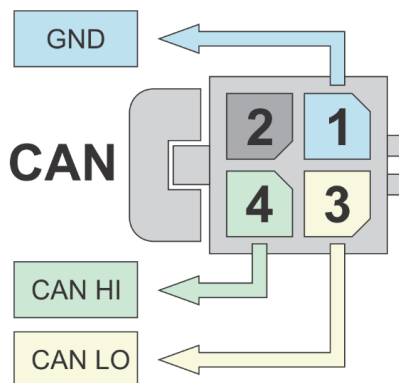

CAN B

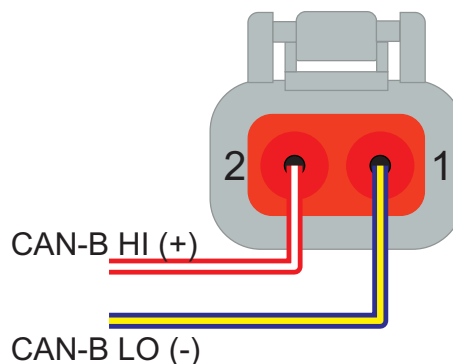

Examples

Example 1: Standard CAN layout – Single packet with RPM value

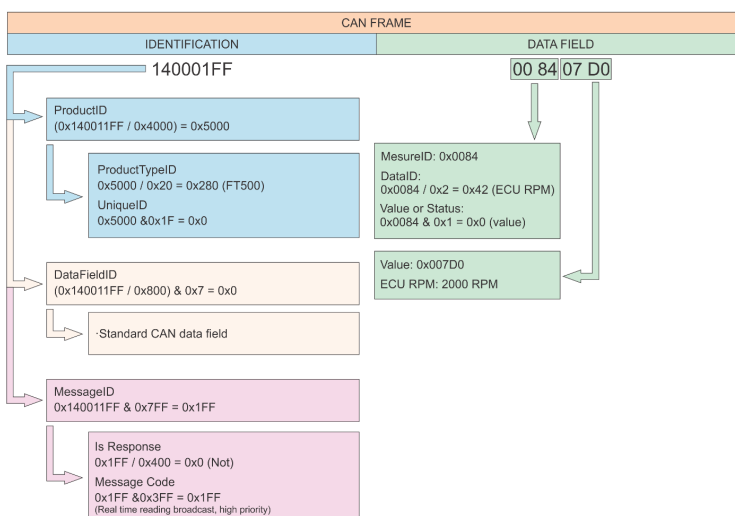

Example 2: Standard CAN layout – Single packet with RPM and TPS values

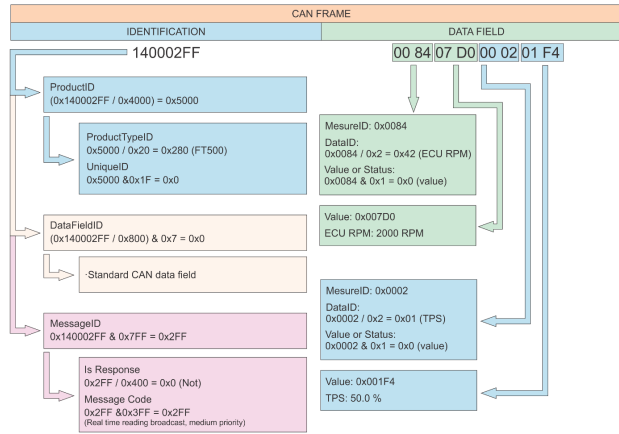

Example 3: FT CAN layout - Single packet with RPM value

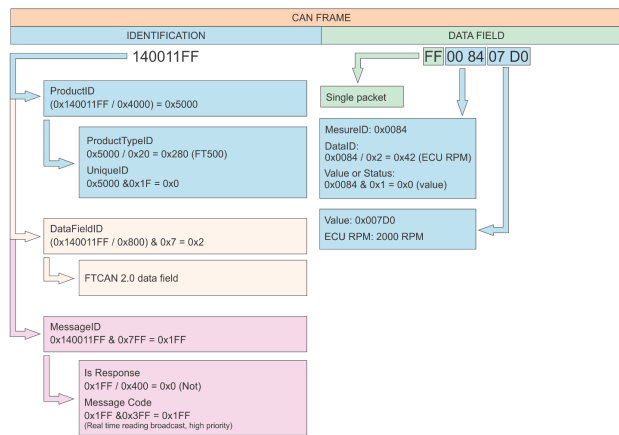

Example 4: FT CAN layout - Multiple packets with 5 different values

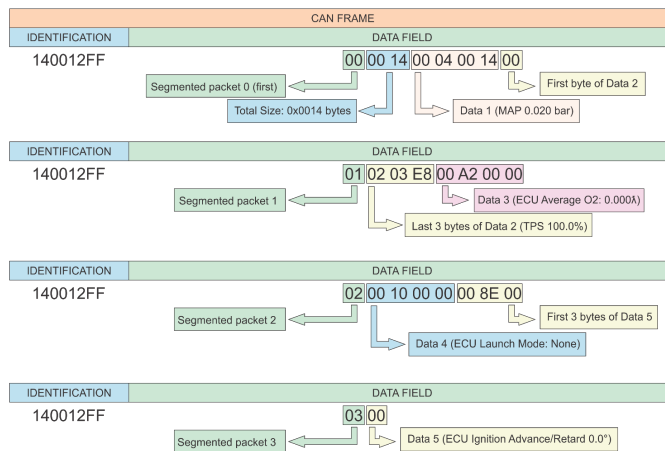



FuelTech

455 Wilbanks Dr.
Ball Ground, GA, 30107, USA

Phone: +1 678-493-3835

E-mail: info@FuelTech.net
www.FuelTech.net

 FuelTechUSA

POWER FT
ECU |