

**FuelTech**

**WB-02 NANO**  
**NANO PRO**



## QUICK INSTALL GUIDE

GUIA RÁPIDO DE INSTALAÇÃO  
GUÍA DE INSTALACIÓN RÁPIDA



METERS &

## 1. Index

2.	Presentation .....	3
2.1	Important Information.....	3
2.2	Characteristics.....	4
3.	Warnings and Warranty Terms .....	5
4.	WB-O <sub>2</sub> Meter Nano Electric Installation.....	7
4.1	Electrical Wiring Diagram .....	8
4.2	Four WB-O <sub>2</sub> NANO V2 harness .....	8
4.3	Electrical wiring WB-O <sub>2</sub> NANO V2 standalone .....	8
5.	Wide band O <sub>2</sub> sensor .....	9
5.1	Bosch LSU 4.2 O <sub>2</sub> sensor.....	9
5.2	Bosch LSU 4.9 O <sub>2</sub> sensor.....	9
5.3	Bosch LSU 5.2 O <sub>2</sub> sensor.....	9
5.4	NTK O <sub>2</sub> sensor .....	9
5.5	O <sub>2</sub> Sensor Installation .....	10
6.	CAN Communication .....	11
6.1	PowerFT Line Configuration.....	11
6.2	Configuration by the FTManager interface .....	12
7.	Lambda Readings analog outputs .....	14
7.1	Lambda Analog Output in Volts – 5.14 to 17.6AFR.....	14
7.2	Lambda Analog Output in Volts – 8.7 to 16.2 AFR (default).....	14
7.3	Lambda Analog Output in Volts – 9.6 to 19.1 AFR.....	14
7.4	Lambda Analog Output in Volts – 9.6 to 58.8 AFR.....	14
7.5	Lambda Analog Output in Volts – 9.6 to 146.9 AFR.....	14
8.	WB-O <sub>2</sub> Meter Nano Codes.....	15
8.1	Informative Codes.....	15
8.2	Error Codes.....	15

## 2. Presentation

FuelTech WB-O<sub>2</sub> NANO V2 is a tool used for monitoring and datalog of air to fuel ratios on combustion engines. The device is able to read and share with the ECU the following oxygen sensors: Bosch LSU 4.2 / Bosch LSU 4.9 / Bosch 5.2 and NTK wide-band sensor.

The WB-O<sub>2</sub> NANO V2 features an extremely compact package size with a integrated waterproof connector and CAN communication capabilities to communicate with the PowerFT ECU's with a minimum of wiring. This CAN communication allows your analog inputs (white wires) to remain un-touched in the event you desire to use multiple O<sub>2</sub> monitors on the same setup over CAN.

The display displays Lambda values well as error messages.

The WB-O<sub>2</sub> NANO V2 uses FuelTech's Advanced Self-Calibration Software, a technology that makes the lambda readings much more precise, and allows the reader in the lambda sensor to compensate for errors in the readings caused by the aging or fatigue of the lambda sensor. Moreover, it uses a Bosch processor, which calibrates automatically through the sensor connector's original laser calibration resistor, dismissing the need for calibration by the user.

There are differences between AFR (air fuel ratio) from the Bosch LSU Sensor 4.2 and 4.9, so it's necessary to correctly configure the Bosch LSU Sensor type.

### 2.1 Important Information

- **The FT500 / FT500LITE are not compatible with the NANO V2 CAN network, but can be connected normally via the analog output wire (yellow/red), connected to a white input on the ECU.**
- **For use the Nano V2, you must have FTManager software version 5.35 or newer.**
- The Nano V2 comes pre-configured from the factory to operate with the LSU 4.2 sensor.
- If you need to change the sensor type configured in the Nano V2, you must connect it to a PowerFT series module (such as the FT450, FT550, or FT600), open the FTManager software, and perform the sensor configuration change.
- To complete this procedure, follow the instructions described in item 7 of this manual.

## 2.2 Characteristics

- Water proof (IP67 Certified)
- Lambda readings shown on the display (2.94 to 146.9 AFR Gas)
- CAN communication with all ECU's (FTCAN 1.0 and FTCAN 2.0)
- Analog output 0-5V
- Compatible with Bosch 4.2 / 4.9 / 5.2 O<sub>2</sub>-sensors and NTK sensor
- Configurable operating range
  - Lambda (0.21 - 9.99)
  - AFR Methanol (1.35 - 64.6)
  - AFR Gasoline (3.09 - 146.9)
  - AFR Ethanol (1.89 - 89.9)
- Dimensions: 2.64" x 1.83" x 1.48" (in)

EN



### NOTE

*O<sub>2</sub> sensor wiring harness are available in two lengths, 78" and 178"*

### 3. Warnings and Warranty Terms

The use of this equipment implies the total accordance with the terms described in this manual and exempts the manufacturer from any responsibility regarding to product misuse.

Read all the information in this manual before starting the product installation.

**This product must be installed and programmed by specialized auto shops and/or personnel with experience on engine preparation and tuning.**

Before starting any electric installation, disconnect the battery.

The inobservance of any of the warnings or precautions described in this manual might cause engine damage and lead to the invalidation of this product warranty. The improper adjustment of the product might cause engine damage.

This product does not have a certification for the use on aircrafts or any flying devices, as it has not been designed for such use purpose. In some countries where an annual inspection of vehicles is enforced, no modification in the original fuel injection system is permitted. Be informed about local laws and regulations prior to the product installation.

#### Limited Warranty

All products manufactured by FUELTECH are warranted to be free from defects in material and workmanship for one year following the date of original purchase. Warranty claim must be made by original owner with proof of purchase from authorized reseller.

This warranty does not include sensors or other products that FUELTECH carries but did not manufacture. If a product is found defective, such products will, at FUELTECH's option, be replaced or repaired at cost to FUELTECH. All products alleged by Purchaser to be defective must be returned to FUELTECH, postage prepaid, within one year warranty period.

This limited warranty does not cover labor or other costs or expenses incidental to the repair and/or replacement of products or parts.

This limited warranty does not apply to any product which has been subject to misuse, mishandling, misapplication, neglect (including but not limited to improper maintenance), accident, improper installation, tampered seal, modification (including but not limited to use of unauthorized parts or attachments), or adjustment or repair performed by anyone other than FUELTECH.

The parties hereto expressly agree that the purchaser's sole and exclusive remedy against FUELTECH shall be for the repair or replacement of the defective product as provided in this limited warranty. This exclusive

remedy shall not be deemed to have failed of its essential purpose so long as FUELTECH is willing and able to repair or replace defective goods.

FUELTECH reserves the right to request additional information such as, but not limited to, tune up and log files in order to evaluate a claim.

**Seal violation voids warranty and renders loss of access to upgrade releases.**

Manual version 1.2 – September/2025

EN

## 4. WB-O<sub>2</sub> Meter Nano Electric Installation

The WB-O<sub>2</sub> Nano has a 12-way connector with 3 wire groups. One of them has the connector for the O<sub>2</sub> sensor, the second makes the CAN communication with PowerFT ECU's and the third is responsible for power and analog output.

By default, the analog output is set to values of 8.7AFR to 16.2AFR Gas, but can be configured to 5.14AFR to 17.6AFR Gas or 9.55 to 19.11AFR or 9.55 to 58.80AFR or yet 9.55 to 146.9AFR (Gas), if necessary.

See the following wiring diagram for details about connections.

EN

### 12-way connector

Wire color	Pin	Connection	OBS
Red	1	O <sub>2</sub> sensor	O <sub>2</sub> sensor pin 6 - IP
Yellow	2	O <sub>2</sub> sensor	O <sub>2</sub> sensor pin 5 - sensor negative signal
Brown	3	O <sub>2</sub> sensor	O <sub>2</sub> sensor pin1 - Sensor positive signal
Red	4	Switched 12V	The use of a 10A fuse is recommended
Yellow/Red	5	0-5V Analog Output	Analog output proportional to the lambda readings. Used for connection with data acquisition systems
White/Red	6	CAN	CAN (+): connected to PowerFT ECU's CAN port
Orange	7	O <sub>2</sub> sensor	O <sub>2</sub> sensor pin 2 - sensor resistor calibration
Green	8	O <sub>2</sub> sensor	O <sub>2</sub> sensor pin 3 - sensor heater positive
Blue	9	O <sub>2</sub> sensor	O <sub>2</sub> sensor pin 4 - Sensor heater negative signal
Black/White	10	Chassis/ Engine Power Ground	Engine ground (head/block) <b>Do not connect it directly to the battery negative.</b>
Black	11	Battery's Negative	Connected <b>directly</b> to the battery negative with no splices. <b>Do not connected this wire to the chassis engine block or head.</b>
Yellow/Blue	12	CAN	CAN (-): connected to PowerFT ECU's CAN port

# WB-O<sub>2</sub> Nano

## 4.1 Electrical Wiring Diagram

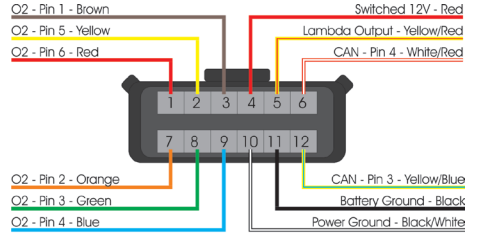

Harness Connector Rear View

## EN 4.2 Four WB-O<sub>2</sub> NANO V2 harness

This harness was developed to power up to four WB-O<sub>2</sub> NANO V2 readers and four wideband O<sub>2</sub> sensors, for builds needing individual fuel reading per cylinder.

Electrical connections and wire colors are the same as a regular WB-O<sub>2</sub> NANO V2.



## 4.3 Electrical wiring WB-O<sub>2</sub> NANO V2 standalone

This electrical wiring is used when the WB-O<sub>2</sub> NANO V2 is installed in an engine where management is performed by another ECU or even carburetor engines.

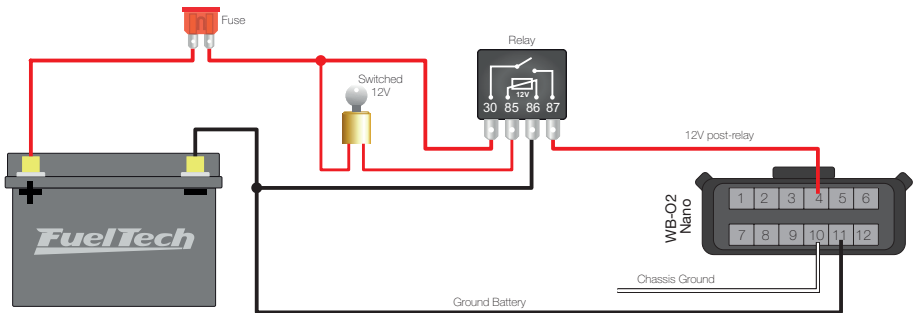

## 5. Wide band O<sub>2</sub> sensor

Better known as the oxygen sensor, it is responsible for reading the exhaust air/fuel ratio. This sensor is essential for engine fine tuning.

### 5.1 Bosch LSU 4.2 O<sub>2</sub> sensor

Bosch LSU 4.2 sensor has an encased heating element and it is used to measure the air fuel ratio, which determines the lambda value in the remaining exhaust gas. Its signal indications vary from 5.14AFR Gas (0,35 λ ) lambda (rich mixture) to open air lambda (infinite).

The connector includes a calibration resistor (factory calibrated), which defines the characteristics of the sensor and it is necessary for its operation. It is with this resistor that the WB-O<sub>2</sub> Nano automatically calibrates the sensor.



Bosch Number: 0 258 007 057 or 0 258 007 351  
VW Number: 021-906-262-B

### 5.2 Bosch LSU 4.9 O<sub>2</sub> sensor

The Bosch LSU 4.9 O<sub>2</sub> sensor works the same as the 4.2



Part number Bosch (Brazil): 0 258 017 025

### 5.3 Bosch LSU 5.2 O<sub>2</sub> sensor

The O<sub>2</sub> sensor Bosch LSU 5.2.



Part number Bosch (Brazil): 1 928 404 719

### 5.4 NTK O<sub>2</sub> sensor

This O<sub>2</sub> sensor is used in engine laboratories, due to its extreme accuracy and speed in reading in different AFRs.

This O<sub>2</sub> sensor requires an free-air calibration.



Part Number FuelTech: 5005100011

### Free-air calibration

The NTK O<sub>2</sub> sensor needs an open air calibration, so after configuring in the software it is necessary to connect the sensor to the WB-O<sub>2</sub> NANO V2 and carry out the calibration.

To perform this procedure, first connect the O<sub>2</sub> sensor to the WB-O<sub>2</sub> NANO V2 and leave it out of the exhaust. Turn the ignition on, and let the NTK O<sub>2</sub> sensor heat up for 5 minutes, then access the sensor setup menu, select NTK, and click on the "calibrate" button.

EN

The calibration process is executed 5 times to guarantee the expected result, after the test a message with the result will appear on the screen. If an error message is displayed, it is necessary to repeat the calibration procedure.

## 5.5 O<sub>2</sub> Sensor Installation

The sensor must be inserted in the exhaust system with its tip exposed to the exhaust gas flow. It must stay in an angle between 10 to 80 degrees to horizontal position, that is, with its end downward, in such a way that steam droplets cannot be accumulated between the body of the sensor and its ceramic part, which could cause damage when the sensor is used. The sensor must not be placed vertically, as it becomes subject to excessive heat.

EN

It is recommended that the sensor is installed at least one (1) meter away from the exhaust manifold to avoid excessive heat, and at least one (1) meter away from the exhaust external output to avoid incorrect readings caused by oxygen in the air outside the exhaust system.

Notice that such recommendations are not obligatory, as vehicles with a smaller exhaust system will need to have the sensor placed closer to the engine.

The sensor must stay away from the cylinder head and from areas where one cylinder might affect the exhaust air more than the others must. Avoid placing the sensor close to the exhaust manifold joints, as some allow the inflow of air, resulting in incorrect readings.

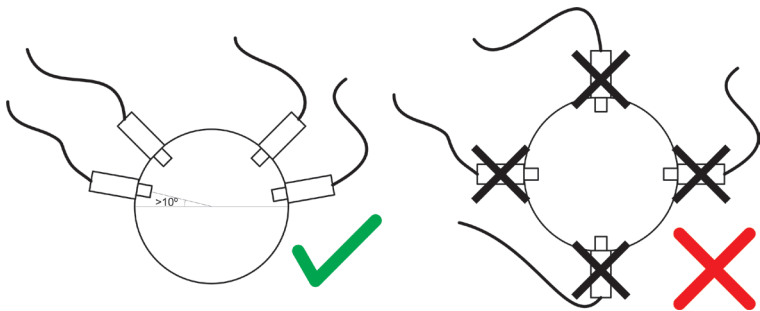

## 6. CAN Communication

The WB-O<sub>2</sub> Nano V2 has CAN communication, which allows the module to send and read information from the PowerFT ECU's that are not. Included on the Nano harness are two 4-way CAN connectors that plug and play with other Nano units as well as the PowerFT ECU's.

When connected to the CAN port, the WB-O<sub>2</sub> NANO V2 can read what the fuel and the measurement unit (lambda or AFR) that the ECU is set, adjusting itself to these settings, disabling the analog output and sending the AFR value to ECU in the range of 5.14 to 149.9 AFR Gas (0,35 λ to 9,99 λ). When used with the FT250 to FT400 range of ECU's you will need to use a 0-5v analog output from the Nano as CAN communication is not possible. In the CAN network, during the O<sub>2</sub> sensor heating period, the value displayed in the PowerFT ECU's will be equal to 0 (zero) and the back of lambda gauge will turn yellow.

In case of any error during work, in addition to the warning on WB-O<sub>2</sub> NANO V2 display, the error will be sent via CAN to the PowerFT ECU's and recorded in "Status Events" log.

To connect the WB-O<sub>2</sub> NANO V2 via CAN to PowerFT ECU's simply plug the 4-way cable to the ECU CAN port.

EN

### 6.1 PowerFT Line Configuration

WB-O<sub>2</sub> NANO V2 CAN Communication can be setup through FTManager Software or through PowerFT ECU's screen.

To setup it through the ECU screen: Go to "Sensors and Calibration" menu, then "O<sub>2</sub> sensor". Select the position where this O<sub>2</sub> sensor is installed on the engine. Then for CAN network, select "CAN 2.0".

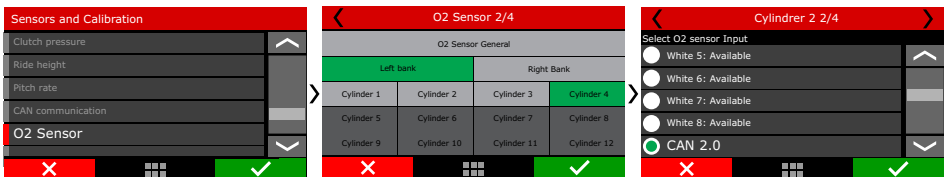

Disconnect the O<sub>2</sub> sensor plug that you want to associate to this position and click "Associate".

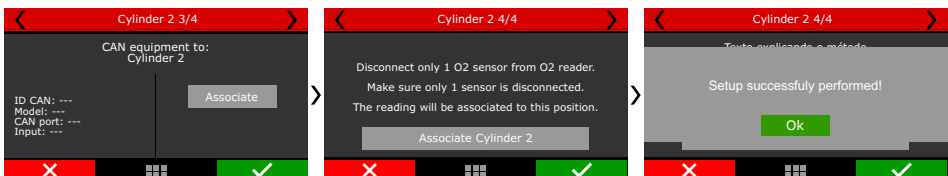

## 6.2 Configuration by the FTManager interface

To configure the WB-O<sub>2</sub> NANO V2 through the FTManager software, follow the steps described below:

- a - Open the map in FTManager software
- b - Access the “*Tools*” menu and then click on “*External Modules*” and locate WB-O<sub>2</sub> NANO V2 and open the configuration screen.

This screen is divided into four distinct parts.

- 1 - **Advanced Settings:** There are three tabs with all the necessary settings for the WB-O<sub>2</sub> NANO V2 to operate correctly
  - **Display and language:** select the language of the WB-O<sub>2</sub> NANO V2 and set the brightness levels for day and night mode.
  - **Heating:** adjusts the O<sub>2</sub> sensor heating mode and sets the parameters of RPM and minimum temperature for the start of heating.
  - **O<sub>2</sub> sensor:** defines which sensor will be used, Unit of measure and the Range of the analog output.
  - **Shift Light:** configures the network protocol used, FTCAN 1.0 or 2.0, as well as triggering alerts and shift light.
  - **Units:** Configures the units for temperature, pressure, speed, consumption and flow.
- 2 - **Buttons and WB-O<sub>2</sub> NANO V2 selection:** there are four buttons for reading and writing the settings in the WB-O<sub>2</sub> NANO V2 memory as well as selecting which device is being configured (if you have more than one WB-O<sub>2</sub> NANO V2 on the CAN network).
- 3 - **Serial number and hardware and firmware version.**

Nano V2

### Advanced Configurations

Sensor Heating Shift Light Language and Display

**Analog out range**

0.35 - 1.20  $\lambda$

0.59 - 1.10  $\lambda$

0.65 - 1.30  $\lambda$

0.65 - 4.00  $\lambda$

0.65 - 9.99  $\lambda$

**Unit**

Lambda

AFR Gasoline

AFR Etanol

AFR Methanol

ECU Synchronized

**Sensor Wideband**

Bosch LSU 4.2

Bosch LSU 4.9

Bosch LSU 5.2

NTK Lab

Calibrate

Read from Nano V2
Write to Nano V2
Erase configuration
Exit



Firmware version

Hardware version

Serial number

Select Device:  

CAN Association: Disassociate

Identify

Disconnected

EN

### Advanced Configurations

Sensor Heating Shift Light Language and Display

**Heating mode**

Normal

Fast

Limited

Limited - Current (A): 3

**Heating startup**

Automatic

By RPM

By temperature

**Startup values**

Engine speed: 1000 RPM

Temperature: 20 °F

### Advanced Configurations

Sensor Heating Shift Light Language and Display

**Shift Light**

Active

Synchronized with ECU

Engine speed: 5000 RPM

### Advanced Configurations

Sensor Heating Shift Light Language and Display

**Day/Night mode selection**

Day mode

Night mode

ECU Synchronized mode

**Display backlight**

Day mode: 4 Nivel

Night mode: 4 Nivel

## 7. Lambda Readings analog outputs

### 7.1 Lambda Analog Output in Volts – 5.14 to 17.6AFR

Lambda	AFR Gas	AFR Methanol/ Ethanol	Volts (V)
0.35	5.14	2.3	0.20
1.20	17.6	7.7	4.80

### 7.4 Lambda Analog Output in Volts – 9.6 to 58.8 AFR

Lambda	AFR Gas	AFR Methanol/ Ethanol	Volts (V)
0.65	9.6	4.2	0.20
4.00	58.8	25.7	4.80

EN

### 7.2 Lambda Analog Output in Volts – 8.7 to 16.2 AFR (default)

Lambda	AFR Gas	AFR Methanol/ Ethanol	Volts (V)
0.59	8.7	3.8	0.20
1.10	16.2	7.1	4.80

### 7.5 Lambda Analog Output in Volts – 9.6 to 146.9 AFR

Lambda	AFR Gas	AFR Methanol/ Ethanol	Volts (V)
0,65	9,6	4.2	0.20
9,99	149,9	64.1	4.80

### 7.3 Lambda Analog Output in Volts – 9.6 to 19.1 AFR

Lambda	AFR Gas	AFR Methanol/ Ethanol	Volts (V)
0.65	9.6	4.2	0.20
1.30	19.1	8.3	4.80

When there is an output reading error, the analog output locks at 0.00V. Thus, it is possible to know if there is any problem or error in the equipment. To configure this output on external equipment, it is necessary to supply the first and last values of the table above.

## 8. WB-O<sub>2</sub> Meter Nano Codes

### 8.1 Informative Codes

When turning WB-O<sub>2</sub> NANO V2 power on, the following information will be displayed:

**Product name**

**Measurement unit (Lambda, AFR gasoline, AFR alcohol or AFR Methanol)**

Analog output scale (as seen on chapter 6)

Cylinder identification (when connected via CAN with PowerFT ECU's): tells which cylinder the conditioner is reading, when used for individual cylinder adjustment.

Then the word HEATING indicates the O<sub>2</sub> sensor heating for operation.

After heated, the word HI appears when AFR above 146.9 AFR Gas (64.1 AFR Alcohol) is read.

### 8.2 Error Codes

Cod	Descriptor	Procedure
E01	E01: internal processor error	It is necessary to send the equipment to FuelTech for repair
E02	E02: Sensor disconnected or damaged	Check connections of the O <sub>2</sub> sensor
E03	E03: Short circuit with the positive on the sensor's heater or damaged heating element	Check connections or replace the O <sub>2</sub> sensor. Check power ground connection
E04	E04: Short circuit with the positive on the sensor's heater or damaged heating element. Power ground problem.	Check connections or replace the O <sub>2</sub> sensor. Check power ground connection
E05	E05: short circuit with the ground on the signal cables or Interference in the O <sub>2</sub> sensor signal cables	Check connections or replace the O <sub>2</sub> sensor. Check power ground connection Check sparks, sparks plugs and cable passageway
E06	E06: short circuit with the positive on the signal cables.	Check connections or replace the O <sub>2</sub> sensor. Check power ground connection
E07	E07: battery voltage under 10V (normal when cranking engine)	Check unit positive and negative connections.
E08	E08: if it blinks during power on, it indicates a communication error. If this code keeps fixed on the screen, may indicate a damaged O <sub>2</sub> sensor or WB-O <sub>2</sub> NANO V2 unit	Try another O <sub>2</sub> sensor. If the problem still unsolved, it is necessary to send the equipment to FuelTech for repair



## **USA**

455 Wilbanks Dr.  
Ball Ground, GA, 30107, USA

Phone: +1 678-493-**FUEL**  
+1 678-493-3835

E-mail: [info@fueltech.net](mailto:info@fueltech.net)  
[www.FuelTech.net](http://www.FuelTech.net)

## **Brasil**

Av. das Indústrias, 864 - Anchieta  
Porto Alegre, RS – Brasil – CEP 90200-290

Fone: +55 (51) 3019 0500

E-mail: [info@fueltech.com.br](mailto:info@fueltech.com.br)  
[www.FuelTech.com.br](http://www.FuelTech.com.br)